



MORRIS GARAGES

Since 1924



G L O S T E R

INDIA'S FIRST AUTONOMOUS LEVEL-1 PREMIUM SUV

OWNER'S MANUAL

IMPORTANT INSTRUCTIONS

- 1 Advanced Driver Assistant System (ADAS) is not a substitute for human eye and driver vigilance. It is a driver assist system that enhances driving experience and safety. The driver shall remain responsible for safe, vigilant, and attentive driving.
- 2 ADAS is driving-assistant system, not fully-autonomous driving. The functions may not operate optimally under all driving conditions. It's operation and effectiveness depends on many factors.
- 3 Driver is responsible for safe and attentive driving. ADAS technologies are not a substitute for the driver's control over the vehicle. See owner's manual for complete details.
- 4 FCW alerts the driver of a possible collision by detecting pedestrian, bicycle or vehicle in front through visual and acoustic sign.
- 5 AEB activates braking intervention to help in preventing collision at slow speed or reduce speed of collision by decreasing the vehicle speed by 40km/h at most (braking intervention for 4Wheeler only).
- 6 Loose objects - Loose objects in the driver's foot area could interfere with the operation of the foot pedals, possibly causing an accident.
- 7 Do not place anything under the front seats, this may damage the motor and electrical wires present below the seat.
- 8 Make sure no loose material (Cloth or other inflammable material etc) is left (but not limited to) inside engine compartment / Engine Cover / Fender after washing.
- 9 Radiator fan may run for few minutes even after Switching OFF the engine. It is a normal phenomenon.



MORRIS GARAGES
Since 1924

- ◆ Do not use blower or infotainment system in engine off mode.
- ◆ Ensure door, hood and tail gate are properly locked.
- ◆ Shift to **P** before switching off ignition.



Welcome to the world of MG!!!

Thank you for choosing MG Gloster

This manual will familiarize you with the operation and maintenance of your new vehicle. It will also provide you important safety information. Please do read it carefully and follow the recommendations. This manual is like a permanent part of your car. It would go a long way in ensuring a safe and trouble-free operation and running of your MG Gloster.

In case of any query, please feel free to call our 24 hours Helpline at 1800 100 6464 or email us at: customercare@mgmotor.co.in

SAFE and HAPPY DRIVING

From

Team MG India

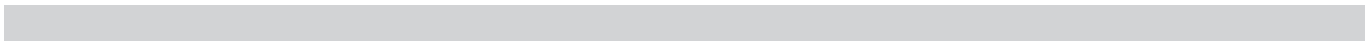

CONTENTS

Preface	1	Properly Seated	32
How to use the manual	1	Seat Belt.....	32
Prompts	1	Seat Belt Pretensioner	39
Precautions	3	Airbag.....	39
Hazardous Materials	3	Child Restraints (not available with the vehicle).....	42
Child/Animal	3	Instruments and Controls	47
Personal Safety	4	Instrument Cluster	48
I BEFORE YOU DRIVE	7	Speedometer	49
Keys	8	Tachometer	49
Remote Key.....	8	Fuel Gauge	49
Extension/Retraction of Mechanical Key Portion	9	Engine Coolant Temperature Gauge.....	49
Replace Battery in Remote Key	9	Information Center	50
Doors and Locks	10	Information Center Type I.....	50
Preventing the vehicle from theft.....	10	Information Center Type II.....	52
Central Lock System	11	Alarm messages	54
Manual tailgate	14	Fatigue driving detection and reminder	55
Power tailgate	14	Tyre pressure monitoring system	56
Child safety door lock	18	Overspeed warning	57
Windows	19	Warning Lamps and Indicators	57
Power window.....	19	Direction Indicator	57
Power Sunroof.....	21	Front Fog Lamp Indicator	57
Seats	22	Headlamp High Beam Indicator	57
Driver seat adjustment	22	Rear Fog Lamp Indicator	58
Front passenger seat adjustment.....	25	Position Lamp Indicator.....	58
2nd Row seats adjustment	25	AFS (Adaptive Front Lighting System) Warning Lamp.....	58
3rd Row seats adjustment.....	29	Airbag Warning Lamp	58
Seat middle armrest adjustment	30	Driver and Front Passenger Seat Belt Warning Lamp	58
Head Restraints	31	Rear Seat Belt Warning Lamp.....	58
Occupant Protection Device	32	Brake System Warning Lamp	59

CONTENTS

ABS (Anti-lock Brake System) Warning Lamp	59	DPF (Diesel Particulate Filter) Warning Lamp.....	66
EBD (Electronic Brake Force Distribution) Warning Lamp.....	59	Urea Warning Lamp	66
ESP (Electronic Stability Program) Indicator Lamp	60	Instrument Panel Switch	67
ESP (Electronic Stability Program) OFF Indicator Lamp	60	Instrument panel illumination control switch	67
Hill Descent Indicator Lamp	60	Adaptive Front-lighting System	67
Engine Malfunction Warning Lamp	60	Hazard warning lamp switch	68
Emission MIL	60	Floor Console Switches	68
Oil Pressure Warning Lamp	61	Switch group in left front side of the shift lever	68
Engine Immobiliser Warning Lamp	61	Switch group in left rear side of the shift lever.....	69
Body Theft Deterrent Warning Lamp.....	61	Switch group in right side of the shift lever	71
Tyre Pressure Monitoring System Warning Lamp	61	Switches on Steering Column and Steering Wheel	72
Battery Charging Indicator Lamp	62	Combination lamp control & direction indicator lamp	
Constant Speed Cruise Indicator Lamp	62	stalk switch	72
Adaptive Cruise Control Indicator Lamp.....	62	Wiper & washer stalk switch	75
Adaptive Cruise Vehicle-to-Vehicle Distance Indicator Lamp	62	Instrument cluster selection and cruise switch	77
4WD Malfunction Warning Lamp	62	Voice control, Bluetooth phone and lcall switch	78
Lane Departure Alert Warning Lamp	63	Steering Wheel Adjustment	79
Intelligent Start/Stop System Indicator Lamp	63	Horn.....	80
AUTO HOLD Indicator Lamp	63	Heating, Ventilation and Air Conditioning.....	81
Electronic Parking Brake (EPB) Indicator Lamp.....	64	Front vents	81
Electronic Parking Brake (EPB) Malfunction Indicator Lamp.....	64	Rear vent.....	82
Electric Power Steering (EPS) System Failure Warning Lamp.....	64	Automatic A/C Front Control Panel	83
Front Collision Warning (FCW) /Automatic Emergency		Electronic A/C front control	87
Braking (AEB) Warning Lamp	64	Automatic A/C rear control panel	89
Ahead Vehicle Indicator Lamp	65	Electronic A/C rear control panel	91
Electronic Differential Lock Indicator Lamp	65	Recommendation for A/C Operation	91
ECO Indicator Lamp	65	Rearview Mirrors.....	92
SPORT Indicator Lamp	65	Exterior Rearview Mirrors	92
Fuel Filter Water Level Warning Lamp	65	Interior rearview mirror	94
Glow Plug Indicator	66		

CONTENTS

Interior Devices	94	Start/Stop the Engine	113
Ceiling reading lamps.....	94	Starting	113
USB port.....	95	Warm-up	114
12V power outlet.....	96	Self-protection mode	114
Mobile phone wireless charging system.....	98	Shutdown	114
Cup holder.....	99	Intelligent Start/Stop System	115
Storage box	100	Basic conditions of usage.....	115
Glove box.....	101	Shutdown and startup of engine.....	116
Sun visor and vanity mirror.....	101	Instructions	117
Glasses box	102	Driving	118
Vehicle tools.....	102	"Running-in" of new vehicle.....	118
MP5+Radio	103	Driving	118
Precautions before Use.....	103	Catalytic Converter	120
Entertainment System Control Switch.....	104	DPF (Diesel Particulate Filter)	121
Introduction and Operation of Main Interface Function	104	Fuel	124
Common Troubleshooting	105	Fuel Filler Cap.....	124
2 STARTING AND DRIVING	107	Refueling	125
Before Starting and Driving	108	Save Fuel	125
Ignition Switch	108	Precautions for Cold Weather.....	126
Keyless Start	108	Urea	127
Keyless Start System	110	Urea refilling	127
Keyless Unlocking	110	8AT Automatic Transmission	128
Keyless Locking	110	Gear	128
Keyless Start	111	Auto Park function	132
Backup Starting.....	111	Manual release of P gear lock (Towing mode)	133
Emergency Flameout	112	Electric Power Steering Device	134
Engine Immobilizer System	112	Four Wheel Drive System (4WD)	135
Keys	112	All-Terrain Four Wheel Drive System (ATS)	135
Enable/disable.....	112	Electronic Differential Lock	138

CONTENTS

Precautions before EDL Use.....	138	3 EMERGENCY TROUBLESHOOTING	183
EDL Use Instruction.....	138	Hazard Warning Lamps	184
Brake System.....	139	Warning Triangle	184
Service brake.....	139	Wheel Replacement	185
ABS (Anti-lock brake system).....	140	Jack	185
ESP (Electronic Stability Program).....	142	Spare wheel.....	185
EPB (Electronic Parking Brake).....	144	Wheel replacement.....	187
AUTO HOLD.....	147	Vehicle Towing	190
Warning lamp	148	Towing Eye.....	190
Constant Speed Cruise Control System.....	148	Towing.....	192
Set Cruise Control	149	Fuel Filter Water Drain.....	192
Terminate the Cruise Control	151	Jump Start.....	193
Clear Speed Memory	151	Battery Disconnection	193
Parking Assist System	151	Jump Start.....	194
Reverse Radar Sensors	151	Fuse Replacement	195
Front and rear radar sensors.....	152	Driver Compartment Fuse Box	195
Reverse Cameras.....	154	Front Compartment Fuse Box	197
360° Around-view System.....	155	Fuse Replacement.....	201
Intelligent Semi-Automatic Parking Assist System	156	Bulb Replacement	202
Driver Assist System.....	158	Bulb Specification	202
Adaptive Cruise Control (ACC)	162	4 MAINTENANCE AND SERVICE.....	203
FCW and AEB	170	Safety	204
Lane Departure Warning (LDW)	175	Regular Maintenance	205
Blind Spot Detection (BSD)	176	Owner Checks	205
Tyres.....	177	Daily Check	205
Tyre chain.....	178	Weekly check or check before a long trip.....	206
Loading.....	178	Severe Working Conditions.....	206
Luggage compartment	179	Front Compartment.....	206
Roof Rack and Load Carrier	181	Engine Hood	207

CONTENTS

Open the Engine Hood.....	207	Wear Indicators	221
Close the Engine Hood	208	Tyre Check and Rotation	221
Engine Oil	208	Other Maintenance	222
Check and Refill	209	Vehicle Wash	222
Engine Oil Consumption.....	210	Engine Carbon Deposit Cleaning	223
Coolant.....	210	Underbody Corrosion Protection	223
Check and Refill	211	Seat and interior trim	223
Brake Fluid.....	212	Door Seals.....	223
Check and Refill	213	Windows.....	223
Washer Fluid.....	213	5 GENERAL TECHNICAL PARAMETERS	225
Check and Refill	213	Main Vehicle Dimension Parameters.....	226
Washer Nozzles	214	Complete Vehicle Mass Parameters	227
Adjust and Clean	214	Complete Vehicle Performance and	
Wiper Blade.....	214	Main Engine Parameters	228
Check.....	214	Chassis Technical Parameters:.....	229
Replacement.....	215	Recommended Fluids	230
Maintenance	215	Wheels and Tyres.....	231
Seat Belt.....	215	Wheel Alignment Parameters.....	232
Check.....	215	MG Motor New Vehicle Warranty.....	233
Maintenance	216	MG Roadside Assistance 24x7.....	239
Battery.....	216	Change of Ownership Record	243
Car parking period	217	Maintenance Interval	245
Winter Operation	218	Maintenance Record Sheet	248
Battery charge with ground equipment.....	218	MG Motor India Sales and Service Network.....	250
Battery removal.....	219		
Battery replacement	219		
Battery installation	219		
Tyres	220		
Tyre Pressures	220		

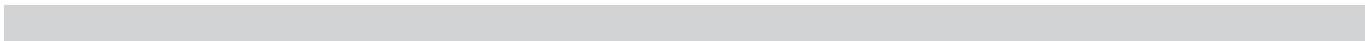

PREFACE

Preface

The vehicle is integrated with advanced technologies, safety, environmental protection and economy.

The Manual provides necessary information to help you drive your vehicle safely and effectively.

The driver shall always note that improper operation of vehicle may cause accidents and injury risks. Moreover, you shall comply with the requirements in laws and regulations of the country. If these requirements are different from those in the Manual, the requirements in the laws and regulations shall prevail.

The staff of MG Authorised Service Center have received professional trainings and can provide complete and satisfactory service for your vehicle. Please contact a nearby MG Authorised Service Center if your vehicle needs maintenance or repair. Please refer to the Subsection “Network details of MG Authorised Service Center” for details of Service Center Contact.

Please carry the Manual with your vehicle for review and reference at any time. If you want to resell the vehicle, please handover the Manual to the new owner along with the vehicle for use when needed.

How to use the Manual

- The contents at the beginning of the Manual and each section are used for locating specific information.
- As for directional data such as front, rear, left and right, the driving direction shall be taken as the front.
- Some functions described in the Manual may not be configured for all models, and the Manual may introduce some devices / functions that are not installed on your vehicle.
- The Manual includes the latest information available at the time of printing the Manual. The Company has the full authorities to take charge of the amendment to and statements on the Manual and reserves the right to make changes to the product without further notice after the Manual is printed. Some of pictures in the Manual are illustrations used here only for your reference. Please refer to real objects.

Prompts

Note

The content marked with “Note” indicates matters need to be noted during vehicle operation. Ignoring such information may lead to wrong operation.

Warnings

The content marked with “Warnings” indicates risks of accidents or injuries. Ignoring such information may lead to injuries.

Caution

The content marked with “Caution” indicates possibility of vehicle damage. Ignoring such information may lead to vehicle damage.

Dangers

The content marked with “Dangers” indicates risks of fatal injuries. Ignoring such information may endanger lives.

“*”: asterisk behind a title or text

“**” indicates that the equipment mentioned is optional, and your vehicle may not have such equipment. Please refer to the actual vehicle for vehicle configuration.

MG Motor India Pvt. Ltd. reserves the copyright of the Manual.

PREFACE

Note

Note: *This is suggestive description which is useful for you.*

Environmental protection



Everyone is obliged to protect the environment. This symbol intends to remind you to pay attention to environmental protection.

Arrows



It indicates the described object.



It indicates the moving direction of an object.

Please refer to

The content referred. It indicates the name of “Section”.

Precautions

Hazardous Materials

 Most liquids and some substances used on a motor vehicle are toxic. It is strictly prohibited to drink them, and keep injuries away from them as far as possible. **Battery acid, coolant, brake fluid, power steering fluid, fuel, cleaning solution, lubricant, refrigerant and other liquids and various adhesives contain these toxic substances. Be sure to carefully read and strictly follow the instructions printed or stamped on parts. This kind of instructions are shown for the sake of your health and personal safety. Please treat them with caution.**

For your safety, please read this manual carefully.

Child/Animal

 **An accident and personal injury may be caused if any unsupervised child or animal operates the control devices and switches installed on the vehicle or contacts any equipment or objects transported by the vehicle.**

In order to prevent the accident or personal injury caused by a child or animal, do not leave the child or animal in the vehicle without adult supervision. In hot days, the child or animal left in the vehicle may suffocate.

Personal Safety



Each seat on your vehicle is equipped with a seat belt to lower the possibility of personal injury in case of an accident. All occupants are required to wear seat belts. In addition, your vehicle has been installed with supplementary restraint system (SRS) comprising an airbag and a seat belt pre-tensioner, providing extra protection for the driver and front passenger.

Please refer to “Supplementary Restraint System (SRS)” in the Before You Drive section. The misoperation of airbag may lead to personal injuries.



MORRIS GARAGES
Since 1924

- ◆ Do not use blower or infotainment system in engine off mode.
- ◆ Ensure door, hood and tail gate are properly locked.
- ◆ Shift to **P** before switching off ignition.

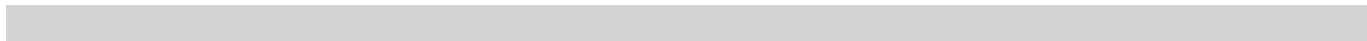

8	Keys
10	Doors and Locks
19	Windows
22	Seats
32	Occupant Protection Device
47	Instruments and Controls
48	Instrument Cluster
50	Information Center
57	Warning Lamps and Indicators
67	Instrument Panel Switch
68	Floor Console Switches
72	Switches on Steering Column and Steering Wheel
79	Steering Wheel Adjustment
80	Horn
81	Heating, Ventilation and Air Conditioning
92	Rearview Mirrors
94	Interior Devices
102	MP5+Radio

Keys

The vehicle is equipped with 2 remote keys with passive entry & passive start system (hereinafter referred to as PEPS).



1 Remote key with PEPS

Note: *If a key is lost, you must provide the key number on the metal or plastic plate attached with the key, and our Service Dealer will provide the replacement. To ensure safety, you are recommended to keep the metal or plastic plate attached with key properly.*

Note: *For the sake of safety, the key has been electronically coded with the engine immobilizer system and can be used with the system in the matching way only. Special procedures shall be followed to manufacture a same key with the lost one. Any uncoded key cannot start the engine but can lock/unlock doors.*

Remote Key

Remote key is a control component of automobile central locking system. It can be used for locking/unlocking all doors.

Note: *The remote key/keys have been electronically coded with the locking/unlocking system and can be used with the system in the matching way only. Special procedures shall be followed to manufacture a same remote key with the lost one. All Service Dealer are ready to provide assistance for you. Please refer to “Central Locking System” in this section for more details about the remote key.*

Caution

The engine immobilizer system can accept 4 coded keys at most (for remote keys with PEPS function).

Extension/Retraction of Mechanical Key Portion

Mechanical Key Portion of Remote Key can be extended or retracted, hereinafter referred to as mechanical key portion.

Mechanical Key Portion of a Remote Key with PEPS

Press the release button on the remote key with PEPS, remove the rear trim panel and pull the mechanical key portion from the key body. To retract the mechanical key portion, directly insert it into the body of remote key with PEPS and close the rear trim panel.

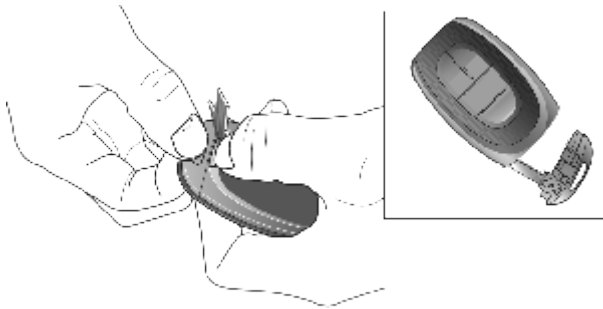

Replace Battery in Remote Key

! Key battery has the risks of fire, explosion and combustion. Do not charge the battery. The used battery shall be disposed in a proper way. Keep the battery in the place out of reach by children.

To replace the battery, operate as per the following steps:

Remote key with PEPS battery replacement

- 1 Release the button on the remote key with PEPS.
- 2 Remove the key head from the key itself.
- 3 Pry the upper and lower panels of the main body, remove the PCB (with battery) from the lower panel.

Caution

Never use a metal tool to pry the PCB.

- 4 Withdraw the old battery and fit the new battery. (Same specification)

Caution

It is essential that the correct battery polarization is observed.

- 5 Put the plastic support with battery into the lower panel of the main body, and install the PCB subsequently.
- 6 Refit the upper and lower panels of the main body.

Caution

Do not miss the waterproof shim onto the upper panel.

7 Press the key head into the main body.

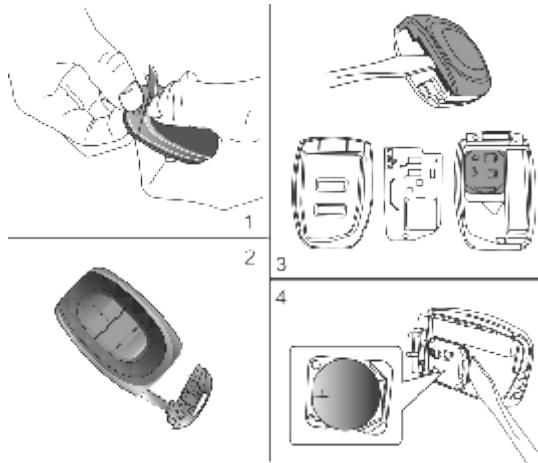

Caution

It is complicated to replace the battery in the remote key with PEPS. In order to prevent the key from being damaged due to misassembly or misoperation, you are recommended to have the battery replaced by our Service Dealer.

Doors and Locks

Preventing the vehicle from theft

! If you leave the vehicle while occupants are left in it, even if the departure time is very short, be sure to remove the key from the ignition switch, and special attention shall be paid especially when a child is left in the vehicle. Otherwise, they may start the engine or operate the electrical device, thus may result in a risk of accident.

Please close all windows before leaving the vehicle.

Please make sure that all doors are fully closed before locking.

Door Lock/Unlock

You may lock/unlock all doors from outside with the remote control with PEPS. You may lock/unlock all doors from inside with the central lock switch. All doors can be locked automatically depending on vehicle speed. Please refer to "Central Lock System" in this section.

Note: When all doors are successfully locked with the remote key, all turning signal lamps will flash once, and the horn sounds once as the reminder. When all doors are successfully unlocked with the remote key, all turning signal lamps will flash twice as the reminder.

Central Lock System

Using mechanical key section of remote control

Perform manual lock/unlock operation on the driver door from outside with the mechanical key section of remote control, all doors can be locked/unlocked.

When locking, turn the mechanical key section of remote control counterclockwise.

When unlocking, turn the mechanical key section of remote control clockwise.

Using remote key

With the buttons on the remote key, you can lock/ unlock all doors through the central lock system.

Note: *The system can operate properly only when all doors are fully closed.*

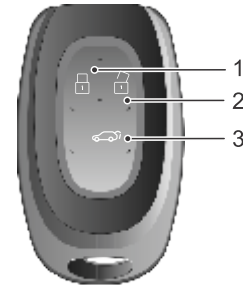

- 1 Center console LOCK button
- 2 Center console UNLOCK button
- 3 Manual tailgate UNLOCK button/Power tailgate UNLOCK & LOCK button

Caution

For vehicles with PEPS system, when locking with the LOCK button on the remote key with PEPS, if there is other legal remote key with PEPS in the vehicle, then the latter key will be disabled, and the passive entry and one touch start feature will be lost. To activate it: Close all doors, operate the UNLOCK button on the remote key with PEPS in a normal manner, the key being shielded inside the vehicle will be activated.

BEFORE YOU DRIVE

Locking all doors

Press the button (1) to lock all doors, but the prerequisite is that all doors are closed.

Note: All turning signal lamps flashing once replacements the confirmation for locking, if any door is not fully closed, there will be no audio alarm, please press the button (1) again after closing all doors.

Unlocking all doors

Press the button (2) to unlock all doors.

Note: If no door is opened within 30 seconds, all doors will be automatically locked again.

Tailgate button

Long press the button (3) for 2 seconds, and the tailgate can be opened (power tailgate can be closed).

Remote door lock with PEPS

PEPS system allows you to lock or unlock the doors without taking the remote key out of your pocket, wallet, or suitcase.

Unlock with the remote key with PEPS

As long as there is a legitimate remote key existing within the range of 1 meter around the vehicle, press the micro switch on the door handle, and the door will be unlocked.

Lock with the remote key with PEPS

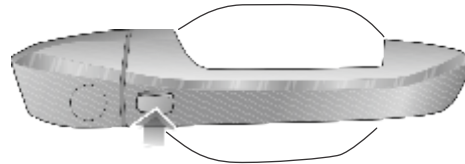

Turn off the ignition switch, leave the vehicle and close the door, then touch the micro switch with your thumb, the door will be locked, and there is no need to press the LOCK button on the remote key.

BEFORE YOU DRIVE

Using central lock switch

This switch can enable or disable all door locks from inside. Press the LOCK button to lock all doors. Press the UNLOCK button to unlock all doors.

Note: *If the driver door is not closed, the lock motor will not activate, if the other door is not closed, the lock motor will activate.*

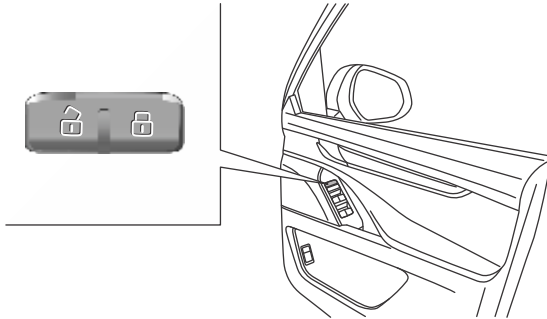

The door can also be unlocked by pulling the inner handle twice.

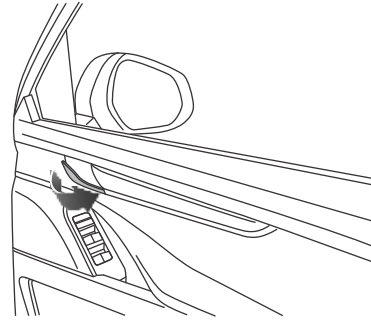

Note: *During the driving, all doors shall be fully closed and all door locks shall be enabled, so as to avoid accidental opening of doors.*

Speed related locking

This function will automatically lock all doors when the vehicle speed is over 8km/h.

Note: *When the key is turned to "LOCK" position, remove the key, and the doors will be automatically unlocked.*

Manual Tailgate

Door unlock/opening from outside

When all doors are locked or unlocked with the key, remote key or central locking switch, the tailgate will also be locked or unlocked. If the tailgate is unlocked, it can be opened by pressing the handle button (1) and pulling it up.

Note: *The tailgate swings up to open. When opening the tailgate, make sure there are no objects or people near the rear of the vehicle.*

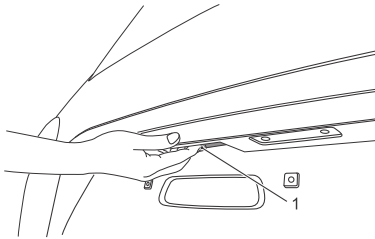

Door closing/lock from outside

To close the tailgate, lower the tailgate and press down firmly. Confirm that the tailgate is firmly locked.

Note: *Confirm that the tailgate has been closed before driving. Driving the vehicle with the tailgate not closed may result in damage to the tailgate pneumatic lifter and other components.*

Power Tailgate

Note: *The tailgate swings up to open. When opening the tailgate, make sure there are no objects or people near the rear of the vehicle. Confirm that the tailgate has been closed before driving. Driving the vehicle with the tailgate not closed may result in damage to the tailgate pneumatic lifter and other components.*

The power tailgate has 4 power opening modes, you may open and close the tailgate according to the configuration of your vehicle.

Tailgate opening/closing switch at the reading lamp

Press the switch  and the tailgate will perform the opening/closing action.

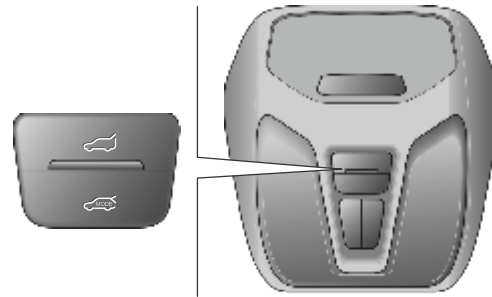



BEFORE YOU DRIVE



Remote key

Long press the  on the remote key for 2 seconds, and the tailgate will perform the opening/closing action.

Switch on the tailgate

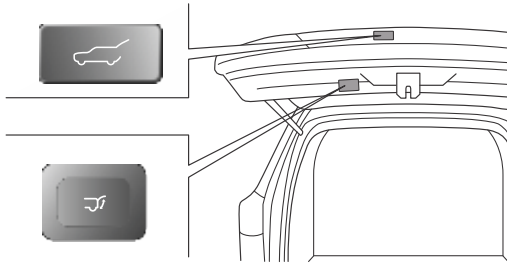
Press the tailgate exterior panel switch  to perform the tailgate opening action. Please ensure that the vehicle is in unlock state, if the vehicle is not entirely unlocked, you need to bring the remote key near the tailgate, and perform the opening/closing action with the tailgate exterior panel switch .



Press the tailgate interior panel switch  to perform the tailgate opening and closing. If the tailgate is open, press the tailgate interior trim panel switch  to close the power tailgate. The switch  can achieve the 2-way action, that is, during the tailgate opening or closing, press the switch to stop the tailgate action, and press it again to perform the reverse action.

Foot kick sensing switch on the tailgate

The tailgate is equipped with an inductive opening system, with the remote key (The remote key must be in a semicircular area with a radius of about 1 m of the tailgate of the vehicle), take a kick action under the rear bumper to open the tailgate. When doing this, gently kick forward with a foot toward the bottom of the rear bumper (as shown in the figure) and then take it back, but do not touch the bumper.

Note: Confirm that the tailgate has been closed before driving. Driving the vehicle with the tailgate not closed may result in damage to the tailgate pneumatic lifter and other components.

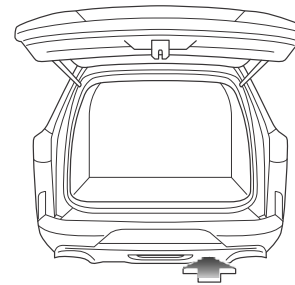

BEFORE YOU DRIVE

Caution

When operating the power tailgate, ensure that no one is in the opening and closing path of the tailgate, or you or others may be injured. During washing your car, ensure that the remote key is kept far away from the rear bumper detection area, for water flushing may cause the tailgate opening. If the rear bumper is covered by a large amount of ice and snow, dirt or similar materials, the Easy-Open Tail Gate feature may be degraded or disabled, so please keep the cleanliness of the rear bumper.

Tailgate height setting

Fully open mode

The fully open mode is the vehicle default mode.

Garage mode

For the garage mode, you need to press the tailgate garage mode switch  mode button at the reading lamp, and then the tailgate will be opened to the set garage height in each opening. The default opening of the tailgate in the garage mode is 75%.

Setting of the garage mode: Manually open the tailgate to the desired height, long press the tailgate interior panel switch button for 3 seconds, if ticks are heard, it indicates that the setting is successful. Press the garage mode switch, the tailgate will be opened to the garage height in the following opening.

Emergency lock function of the tailgate

The tailgate has emergency lock function, in case of whole vehicle power-off or other power tailgate failures, you may open the cover at the lower end of tailgate interior trim panel, push the lever in it to open the tailgate.

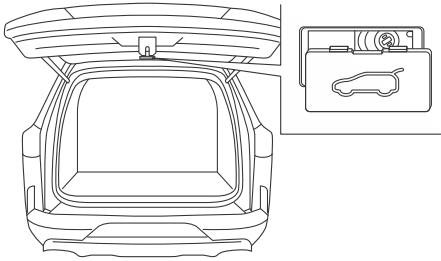

Note: For vehicle models with automatic transmission, only when the shift lever is placed in "P" position can the power tailgate be opened or closed.

If no operating instruction is received 15 minutes after the power tailgate is opened, the tailgate enters the suspend mode. The customer needs to close the door manually once to restore the power mode. When the power tailgate is opened again, it can be opened and closed electrically.

The power tailgate cannot be opened and closed consecutively for 10 cycles, or the thermal protection may be activated. If the tailgate thermal protection of your vehicle is activated, be sure not

to operate the tailgate, and wait for 1 minute, and proceed the tailgate operation after the thermal protection disappears.

If the tailgate encounters an obstacle in the power opening or closing cycle, the tailgate will automatically move in the opposite direction to avoid the obstacle. After the obstacle removal, you may operate the power tailgate again. If the tailgate encounters obstacles for consecutive 3 times in the power closing or opening process, the power function will be disabled. After the obstacle is removed, manually close the tailgate, and the normal power operation can be restored. The anti-pinch sensor is located at the side of the tailgate, when the tailgate is closed, if there is an obstacle between the tailgate and vehicle and the sensor is squeezed, the tailgate will rotate 5° in the opposite direction.

When operating the power tailgate, ensure that no one is in the opening and closing path of the tailgate, or you or others may be injured.

Tailgate follow-up movement strategy: when the power tailgate is in the ajar position, it will be automatically closed when a force is applied on it.

Please do not forcibly open or close the tailgate by hand in the power operating cycle.

When the vehicle is on a ramp of 12° or above, please close the tailgate with the assist of your hands, and please note that the closing action must be slow, and do not close the tailgate rapidly and forcibly.

BEFORE YOU DRIVE

If the battery is disconnected or the voltage is too low, then the tailgate cannot be opened. When the battery is reconnected or charging, the tailgate will resume its operation.

Child safety door lock

 **Where a child sits in the rear passenger seat, the doors should be locked by the child safety door locks.**

Each side rear door of your car is provided with a child safety door lock. These doors are used to prevent passenger, especially the child, from opening the side rear door due to careless pulling of the internal door handle.

Caution

When the child safety lock is locked, do not pull the internal door handle with a heavy force. This practice will cause damage to the internal door handle.

The left rear door's child safety door lock

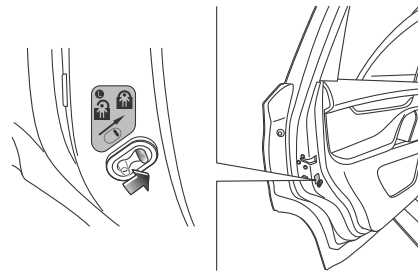

The right rear door's child safety door lock

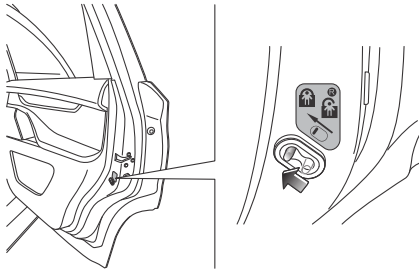

To start the child safety door lock:

- 1 Open the side rear door you want to lock.
- 2 Find the child safety lock control lever.
- 3 Pull the control lever to the locking position .

Caution

Each side rear door is provided its respective lock. The child safety door lock of each side rear door must be activated or deactivated by hand, regardless of the lock at right side or left side.

To open the side rear door after the child safety door lock is activated, the door can be opened only by the external door handle. To deactivate the child safety door lock, it is necessary to push the control lever up to the unlocking position .

Windows

 It is dangerous to leave children, incapacitated adults or pets on the vehicle with windows closed. They may faint out due to high temperature, or suffer permanent injury or even death due to heat stroke. Do not leave children, incapacitated adults or pets on the vehicle, especially in the warm or hot weather, with the windows closed.

Power window

 Always take care when operating the power window. There is a risk of injury, especially for the children. Please pay close attention when closing the window. Ensure that no objects are stuck in it while the window is moving.

Driver door window

There are 4 window switches  on the driver door. You can operate driver door window, front passenger door window and rear door windows respectively with these 4 switches.

When operating, press the front part of the switch to open the window. Pull the front part of the switch to close the window.

The driver may operate the lock button  to disable the power windows for rear occupants. To enable this function, press the lock button again.

BEFORE YOU DRIVE



Automatic lifting function of driver door window

Your vehicle may be equipped with one-touch up/down or one-touch down function. Button 1 has 2 levels: auto up/down and stroke up/down, so it can conveniently control the window glass up/down process. Briefly press the window button up or down to the second level, and the window glass will automatically move up or down.

Resume the automatic up/down function

If the vehicle battery cable is re-connected after the disconnection, or the battery was drained once, or the anti-pinch function has been enabled for consecutive 3 times at the same position when the window glass moves up, the automatic up/down function may not work, it must be re-learned to restore the function.

Close all doors, pull up the window glass lifting button, until the window is fully closed, hold the button for about several seconds after the window is fully closed; then press the window glass lifting button until the window is fully open, hold the button for about several seconds after the window is fully open, the automatic up/down function will resume.

Occupant door windows

There is only 1 window switch on each occupant door  , which can only operate the corresponding occupant door window.

When operating, press the front part of the switch to open the window. Pull the front part of the switch to close the window.

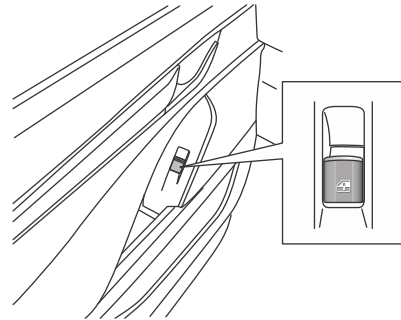

Note: Power windows can operate only when the ignition switch is in "ON" position.

Power Sunroof

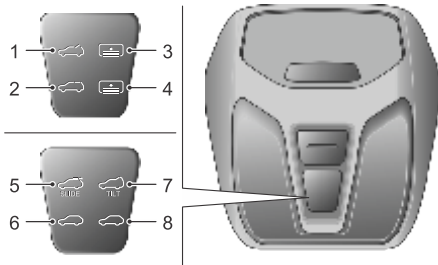

Position 1 - : Panoramic Sunroof Open switch.

Position 2 - : Panoramic Sunroof Close switch.

Note: The opening and closing of panoramic sunroof has 2 gears: tilt for ventilation and fully open, makes it easy to control the opening and closing process of the sunroof. With the first gear of the switch, the sunroof will be opened or closed to the tilt for ventilation position, with the second gear of the switch, the sunroof will be fully opened or closed. Meanwhile, both the opening and closing of panoramic sunroof switch are equipped with jog and auto function, make it easy to control the opening and closing process of the sunroof. Short press the second gear of the operating button, the sunroof will be automatically opened or closed. Long press the first gear for jog function.

Position 3 - : Sunshade Open switch.

Position 4 - : Sunshade Close switch

Note: Both the opening and closing of sunshade switch are equipped with jog and auto function, make it easy to control the opening and closing process of the sunshade. Short press the second gear of the operating button, the sunshade will be automatically opened or closed. Long press the first gear for jog function.

Position 5 - : Sunroof Slide Open switch. When the sunroof slides open, release the button to stop the sunroof at the desired position.

Position 6 - : Sunroof Slide Close switch. When the sunroof slides close, release the button to stop the sunroof at the desired position.

Note: Both the opening and closing of sunroof switch are equipped with jog and auto function, make it easy to control the opening and closing process of the sunroof. Short press the second gear of the operating button, the sunroof will be automatically opened or closed. Long press the first gear for jog function.

Position 7 - : Sunroof Tilt Open switch. When the sunroof tilts open, release the button to stop the sunroof at the desired position.

Position 8 - : Sunroof Tilt Close switch. When the sunroof tilts close, release the button to stop the sunroof at the desired position.

BEFORE YOU DRIVE

Seats

Driver seat adjustment

! Do not adjust the driver seat while the vehicle is running. If so, the vehicle may be out of control and result in an accident.

Manually adjusted driver seat

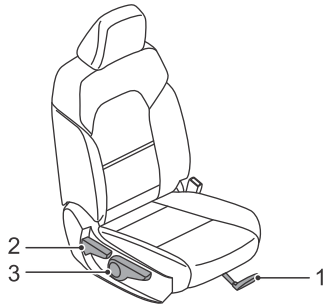

Forward/backward sliding

Pull up the handle (1), and slide the seat to the desired position. Release the handle (1) and confirm that the seat is locked in place.

Backrest Adjustment

! The tilt angle of driver seat should not be too large, the seat belt can provide the maximum protection only when the seat back forms an angle of about 25° with the vertical direction.

With the body tilting slightly forward, pull up the adjusting handle (2), the seat back will automatically bounce back, then recline against the seat back to adjust it to the desired angle. Release the adjusting handle (2) and confirm that the seat back is locked in place.

Cushion Height Adjustment

Pull up the adjusting handle (3) to raise the seat height, and press the handle (3) to lower the seat height. When making significant adjustments, it is required to pull up and press the handle (3) consecutively.

Electrically adjusted driver seat

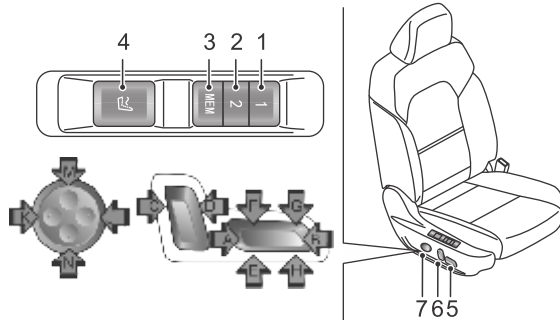

Caution

Regardless of where the ignition switch is placed, the seat can be slide back and forth, the backrest and the tilt angle and height of cushion can be adjusted. But the electrical adjustment is power consuming, which may drain the battery. The lumbar support adjustment and massaging and memory position functions can be enabled after the engine start.

Forward/backward sliding

When the button (5) is pushed forward (arrow A), the seat will move forward, and when the seat slides to the desired position, release the button (5) to stop the seat sliding.

When the button (5) is pushed backward (arrow B), the seat will move backward, and when the seat slides to the desired position, release the button (5) to stop the seat sliding.

Backrest Adjustment

! The tilt angle of driver seat should not be too large, the seat belt can provide the maximum protection only when the seat back forms an angle of about 25° with the vertical direction.

When the button (6) is rotated forward (arrow C), the seat backrest will tilt forward, when the seat backrest tilts to the desired position, release the button (6) to stop the tilting.

When the button (6) is rotated backward (arrow D), the seat backrest will tilt backward, when the seat backrest tilts to the desired position, release the button (6) to stop the tilting.

Cushion Inclination Adjustment

When the front end of button (5) is pulled upward (arrow H), the front end of cushion will raise, when the cushion tilts to the desired position, release the button (5) to stop the cushion movement.

When the front end of button (5) is pulled downward (arrow G), the front end of cushion will lower, when the cushion tilts to the desired position, release the button (5) to stop the cushion movement.

Cushion Height Adjustment

When the rear end of button (5) is pulled upward (arrow E), the cushion will move upward, when the cushion raises to the desired position, release the button (5) to stop the cushion movement.

When the rear end of button (5) is pulled downward (arrow F), the cushion will move downward, when the cushion lowers to the desired position, release the button (5) to stop the cushion movement.

Lumbar Support Adjustment

When the front end of button (7) is pressed and hold (arrow J), the lumbar support will move forward, when the lumbar support moves to the desired position, release the button to stop the lumbar support movement.

When the rear end of button (7) is pressed and hold (arrow K), the lumbar support will move backward, when the lumbar support moves to the desired position, release the button to stop the lumbar support movement.

When the upper end of button (7) is pressed and hold (arrow M), the lumbar support will move upward, when the lumbar support moves to the desired position, release the button to stop the lumbar support movement.

When the lower end of button (7) is pressed and hold (arrow N), the lumbar support will move downward, when the lumbar support moves to the desired position, release the button to stop the lumbar support movement.

Massaging

Press the button (4) to carry out a massaging, 10 minutes later, the massaging will be automatically turned off after the completion of 30 seconds' bleeding. If the button (4) is pressed again within 10 minutes, the massaging will be turned off.

Memory Position Function Setting

- Storage

Press (press and release) the memory switch button (3) first, then press the button (1) in 3 seconds until a sound of buzz is heard, which indicates the successful completion of memory and that the seat posture and the position of exterior rearview mirrors at the time have been stored in the button (1).

Press (press and release) the memory switch button (3) first, then press the button (2) in 3 seconds until a sound of buzz is heard, which indicates the successful completion of memory and that the seat posture and the position of exterior rearview mirrors at the time have been stored in the button (2).

- Recall

Press the button (1) or (2), to recall the seat posture and the position of exterior rearview mirrors stored correspondingly. During the recall, operate any adjusting switch of the seat or the exterior rearview mirror to stop the recall; press the corresponding button again to continue the recall.

Front passenger seat adjustment

Manually adjusted front passenger seat

Only forward/backward sliding and seat backrest adjustment can be made, and its adjustment is consistent with that of manually adjusted driver seat.

Electrically adjusted front passenger seat

Only forward/backward sliding, seat backrest adjustment and lumbar support adjustment can be made, and its adjustment is consistent with that of electrically adjusted driver seat.

2nd Row Seats Adjustment

Type I

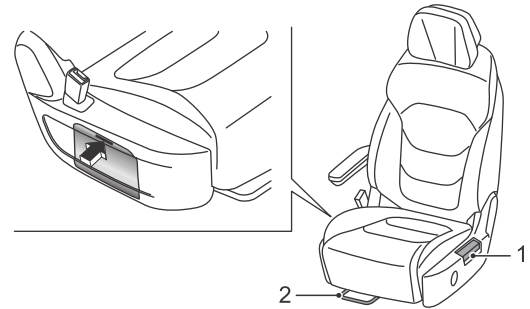

Seat Backrest Adjustment

With the body tilting slightly forward, pull up the handle (1), then recline against the seat back to adjust it to the desired angle. Release the handle (1) and confirm that the seat backrest has been locked in place.

Forward/backward sliding

Pull up the unlock lever (2), pull forward or push backward with your feet to adjust the seat position, release the unlock lever (2), and confirm that the seat backrest has been locked in place.

BEFORE YOU DRIVE

Lumbar Support Adjustment

Its adjustment is consistent with that of electrically adjusted driver seat.

Lumbar Support Massaging

Its adjustment is consistent with that of electrically adjusted driver seat.

Foldable Cup Holder

The left individual seat is equipped with a foldable cup holder, press the location indicated by the arrow, the cup holder will eject. Press the cup holder inward when it is not in use.

Armrest Adjustment

There are 6 positions for the armrest adjustment, from the lowest position upward to the desired position. To adjust the armrest from the high position to the low position, it is required to adjust it to the highest position first, then to the lowest position and then adjust it upward to the desired position.

Type II

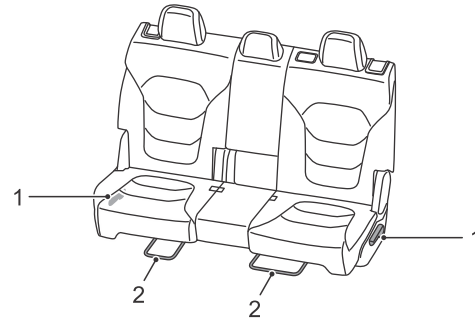

Seat backrest adjustment

With the body tilting slightly forward, pull up the handle (1), then recline against the seat back to adjust it to the desired angle. Release the handle (1) and confirm that the seat backrest has been locked in place.

Seat backrest folding adjustment

Move the head restraint to the lowest position before the adjustment. Pull up the handle (1), the seat can be automatically flattened. The user can also flatten the 2nd row seats from the luggage compartment. Pull the handle (3) outward, the right 2nd row seat will be automatically flattened. Pull the handle (4) outward, the left 2nd row seat will be automatically flattened.

BEFORE YOU DRIVE

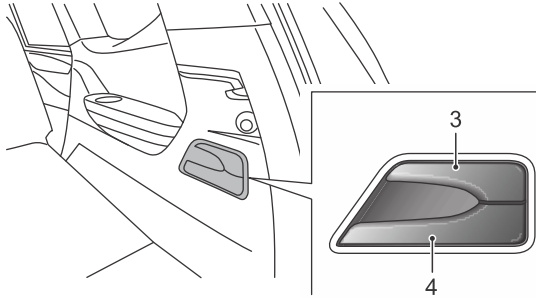

Lift the seat backrest until it is locked, so that the seat backrest is restored to the position for normal use.

Caution

When the 2nd row seat backrests are folded, they may interfere with the front seats, be careful to avoid bumping.

Forward/backward sliding

Pull up the unlock lever (2), pull forward or push backward with your feet to adjust the seat position, release the unlock lever (2), and confirm that the seat has been locked in place.

Easy entry function for the 2nd row three-abreast seats

This function will provide convenience for the entry/exit of 3rd row passengers.

Entry/exit of 3rd row passengers from the right side

Pull up the unlock lever (5), tilt the seat backrest forward at a certain angle, and move the seat to the foremost position. At this time, the rear passengers can get on/off the vehicle from the right side.

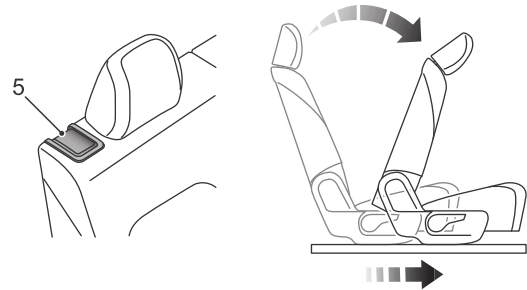

After the entry/exit of rear passengers, restore the seat backrest position, and move the seat backward to the locked position.

BEFORE YOU DRIVE

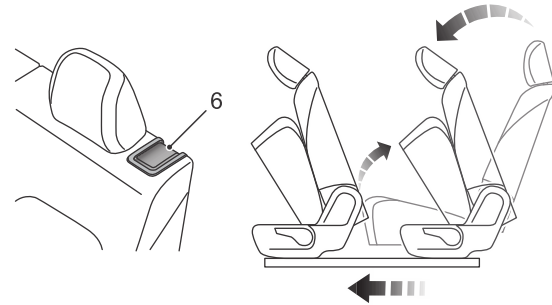
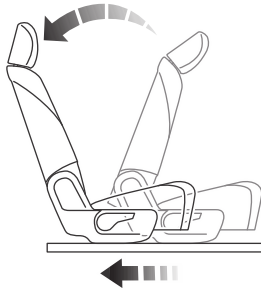

Entry/exit of 3rd row passengers from the left side

Pull up the unlock lever (6), tilt the seat backrest forward at a certain angle, the seat cushion will be automatically folded upward, and then move the seat to the foremost position. At this time, the rear passengers can get on/off the vehicle from the left side.

After the entry/exit of the passenger, restore the seat backrest position, and press the cushion downward to the locked position after the backrest is locked. If necessary, adjust the seat forward or backward to the appropriate position through the slide rod.

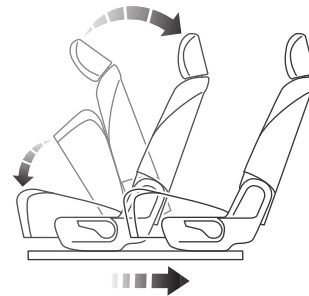

3rd Row Seats Adjustment

Seat backrest folding forward

Caution

With the 2nd row seat backrests tilting backward, folding the 3rd row seats may interfere with the 2nd row seats, at this time, please move the 2nd row seats forward or decrease the titling angle of 2nd row seat backrests.

Straighten the buckle and webbing and put the buckle back in the seat slot, otherwise the buckle will protrude against the seat back when the seat back is laid flat, which tends to cause damage to the seat trim cover.

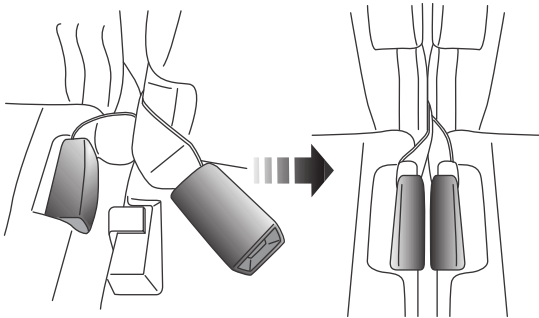

Move the head restraint to the lowest position before the adjustment. Pull the unlock strap at the upper part of the seat backrest forward to unlock the seat backrest, fold the backrest forward until it is against the cushion.

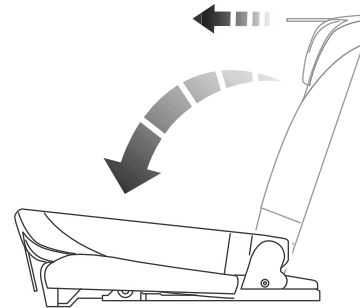

BEFORE YOU DRIVE

Seat backrest unfolding backward

Pull the unlock strap at the back of the seat backrest to rear upper side, to unfold the seat backrest backward to the locked position. Adjust the head restraint to the locked position.

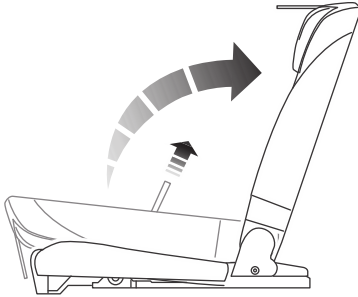

Caution

When the third row seats are being used, the head restraint must be lifted up and out of the stowage position and locked in the use position.

Seat middle armrest adjustment

Pull it down and push it forward for use.

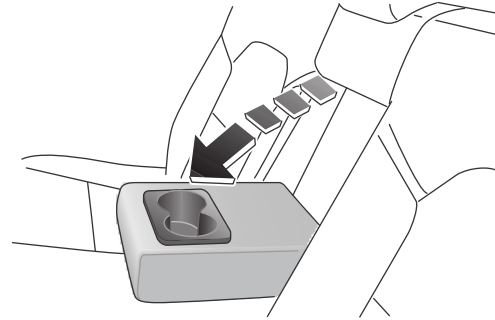

Caution

Do not sit on the central armrest or place heavy objects on it.

BEFORE YOU DRIVE

Head Restraints

! To reduce the risk of neck or head injury, the head restraints shall be adjusted to support the back of the head rather than the neck. Before driving, adjust and ensure that the head restraints of front and rear seats are in locked position (this locked position is the safe use position). Do not adjust the head restraint while the vehicle is running.

Type I

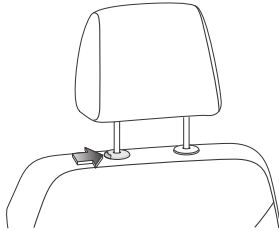

Pull the head restraint upward to adjust it to the desired position. To remove the head restraint after lifting it to the highest position, press the button indicated by the arrow.

Press the button indicated by the arrow to push the head restraint downward to the desired position.

Type II

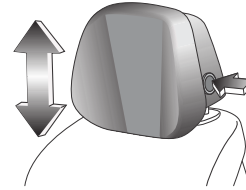

Press the button indicated by the arrow to push the head restraint downward or pull it upward, so as to adjust the head restraint to the desired position.

The head restraint can be adjusted back and forth, pull the head restraint hard to the desired position, then release it. When the head restraint is pulled to the very front, it will restore to the final position after release.

Both sides of the head restraint are adjustable. Rotate both sides of the head restraint hard to the desired position, then release it.

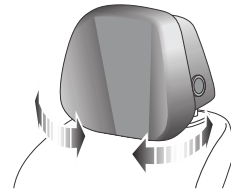

Occupant Protection Device

Properly Seated

The seats and the occupant protection device are designed to minimize the risks of personal injuries when accident occurs. Observe the following points to achieve the best results:

- Do not make the seat too close to the steering wheel.
- Do not tilt the seat excessively. Do not tilt the seat back more than 30°, so that you can seat yourself vertically with the slightly bent arms and the root of the spine should be backward as possible as you can.
- The center of the head restraints should be adjusted to the back of your head, rather than the neck.
- The shoulder belt should go through the center of your shoulder (adjust its height as necessary), while the lap belt should be put around the hip tightly, rather than the abdomen.

Seat Belt



Improper seat belt wearing or use may result in the serious personal injury or death. The seat belt is one of Life-saving equipments. In the event of accidents, the unprotected occupant may knock against any part of the vehicle or be thrown out of the vehicle, resulting in himself/herself or others being injured. The driver and any adults (Including children with body height similar to that of an adult) must always wear a seat belt on all journeys. Do not loosen the belt that fastened on your body. The seat belt must be always fastened tightly around the body to achieve the best protection. Avoid wearing the thick and big volume clothing. Have the shoulder belt of seat belt across the middle of the shoulder and the lap belt across the crotch against the body. The use of loon or twisted seat belt is strictly prohibited, and the seat belt cannot be worn twisted.

Each belt should be used by just one occupant only. Do not put a belt around a child seated on the occupant's lap. The seat belt is intended for use by adult-sized occupants only. Children should be restrained in the correct child restraint device.

The belt should be straight and fastened when you wear it, otherwise, the belt can not be operated smoothly. The buckle button must be facing outward.

BEFORE YOU DRIVE

 **Do not hold an infant or child on your lap. They will become too heavy to restrain in case of collision.**

Prevent the foreign materials (especially the sugary food and drinks) from entering the seat belt buckle, as those materials may cause the buckle fault.

If the seat belt has been used in a severe accident or shows signs of severe fraying or having been cut, or when a seat belt is equipped with a pre-loading device, when the latter has been activated, the seat belt assembly shall be replaced.

The expectant mother should ask the doctor about the safest method to wear the belt.

Do not modify or change the seat belt in any way as this may cause the belt fault. Do not disassemble, repair or lubricate the retractor or buckle mechanism.

Each seat belt is equipped with a retractor, when a seat belt is pulled out slowly, the retractor can ensure the smooth retraction of the belt. But if a seat belt is pulled out too fast, or in a sudden impact (hard deceleration, acceleration, and a sharp turn), the seat belt will be locked. Please refer to "Seat Belt" in Maintenance and Service section for specific check methods.

 **When not in use, be sure to fully retract the seat belt webbing, straighten the webbing and put the locking tab in place, keep the webbing and locking tab clean and away from dust and impurities.**

Care shall be taken to avoid erosion to the webbing caused by polishing agents, oils and chemicals (especially battery acid). The belts can be safely cleaned with mild soap and water. The seat belt shall be replaced when the webbing has wear, erosion and damage occurred.

This vehicle series are equipped with lap-shoulder belts, and the lap-shoulder belts are classified into the adjustable seat belt without pretensioner, the adjustable seat belt with pretensioner, and the adjustable seat belt with dual pretensioners. Only the front seats can be equipped with the adjustable seat belt with dual pretensioners. Only the front seats and outboard seats of the second row may be equipped with the adjustable seat belt with pretensioner.

 **When the locking tab is pushed into the buckle, the seat belt is locked until a clear "clicks" is heard.**

BEFORE YOU DRIVE

Adjustable Seat Belt with Pretensioner (Shoulder Belt Pretensioner)

In the event of serious collision accident, the pretensioner (integrated into the retractor) will be activated by the sensor, the shoulder belt (1) will be retracted a little immediately to prevent the occupants from moving forward and make them seated securely, so that it improves the function of the seat belt further.

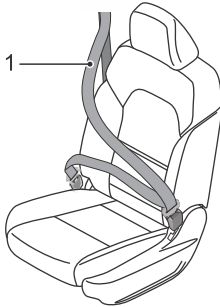

Adjustable Seat Belt with Dual Pretensioners (Shoulder/Lap Belt Pretensioner)

In the event of serious collision accident, the dual pretensioners (one integrated into the retractor, the other integrated into the side lap belt alarm) will be activated by the sensor, the shoulder belt (1) and the lap belt (2) will be retracted a little immediately at the same time to prevent the occupants from moving forward and make them seated securely, so that it improves the function of the seat belt further.

Caution

The outer locking tab (3) does not need to be unlocked in the daily use. The outer locking tab (3) should be unlocked by using the special tool, please ask our Service Dealer to unlock it, if necessary.

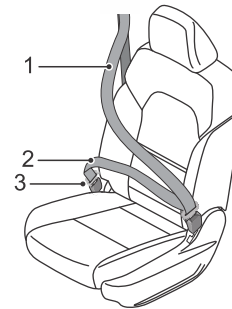

Seat Belts for Front Seats

Fastening

Pull out the seat belt slowly, have it passed over the shoulder and then the front of the body, confirm that it is not twisted or tied, then push the locking tab into the buckle until a click is heard.

Releasing

Press the red button on the buckle, then the locking tab will pop out under the action of the elastic force. Deliver the locking tab back manually, so that the automatic seat belt retractor can fully retract the seat belt more smoothly.

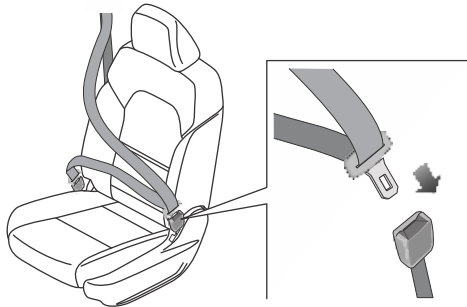

Seat Belts for 2 Seats in Second Row

The seat belts for 2 seats in 2nd row are fastened and released in the same way as the seat belts for front seats.

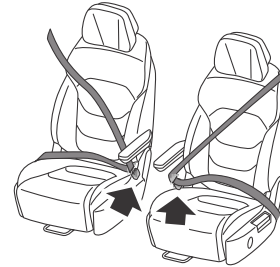

Seat Belts for 3 Seats in Second Row

The seat belts for 3 seats in second row are fastened and released in the same way as the seat belts for front seats.

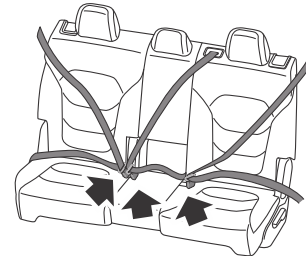

BEFORE YOU DRIVE

Seat Belts for 2 Seats in Third Row

The seat belts for 2 seats in third row are fastened and released in the same way as the seat belts for front seats.

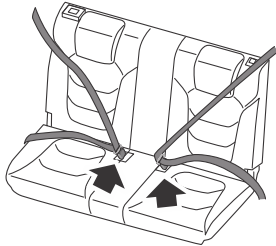

Seat Belts for 2 Outboard Seats in Third Row

The seat belts for 2 outboard seats in third row (with 3 seats) are fastened and released in the same way as the seat belts for front seats.

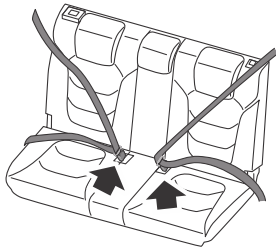

Ceiling Seat Belt for Middle Seat in Third Row (With 3 Seats)

Fastening

Pull out the seat belt from the ceiling, have the fixed locking tab (2) pushed into the left buckle, and have the movable locking tab (1) passed over the abdomen and pushed into the right buckle.

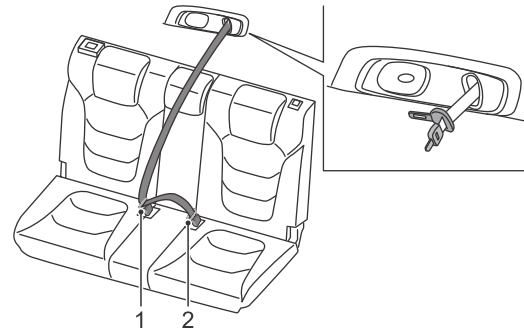

Seat Belt Comfort Guide Ring

The seat belt comfort guide ring is fitted on the shoulder belt, which can take the shoulder belt away from the head of the left occupant.

Take the guide ring out of the seat back storage bag.

BEFORE YOU DRIVE

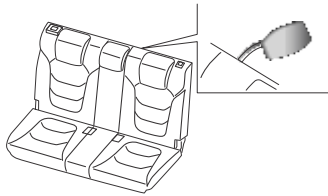

Put the guide ring on the shoulder belt, then insert both edges of the seat belt into the opening of the guide ring.

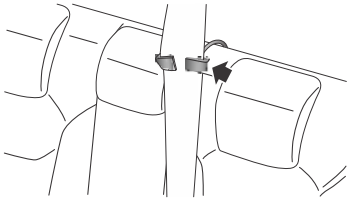

Ensure the seat belt is smooth, and the guide ring must be above the seat belt.

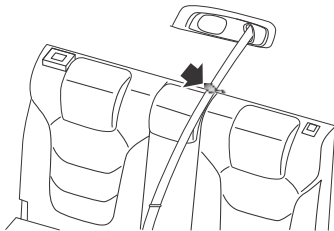

Releasing

To withdraw the seat belt comfort guide ring, squeeze both edges of the seat belt together and remove the seat belt from the guide ring. Then stow the guide ring in the seat back storage bag.

The movable locking tab (1) is unlocked by pressing the red button on the right buckle.

The fixed locking tab (2) can be drawn out by inserting a key or other sharp objects into the left buckle unlocking hole. Deliver the locking tab back manually, so that the automatic seat belt retractor can fully retract the seat belt more smoothly.

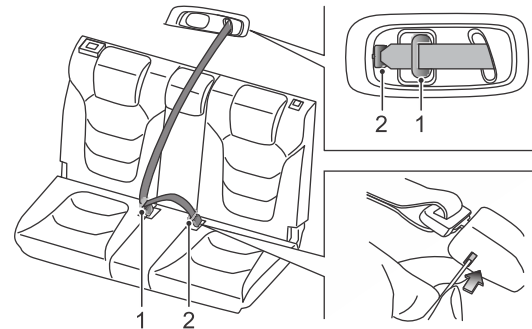

Note: After the seat belt is retracted to the ceiling, the locking tab can be clipped on the ceiling.

BEFORE YOU DRIVE

Plastic Hooks for Side Seat Belts

When not in use, the side seat belts for second and third rows can be snapped into the side seat belt hooks.

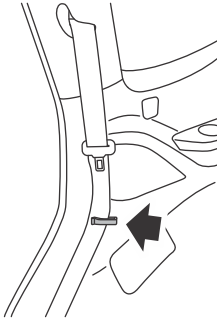

Seat Belt Warning Lamp

For the specific details of “Seat Belt Warning Lamp”, please refer to “Information Center” and “Warning Lamps and Indicators” in this section.

Seat Belt Height Adjustment

 **Ensure that the sliding adjuster is secured after the adjustment.**

Do not adjust the height of the driver seat belt when driving, or the vehicle may be out of control.

Only the height of the driver and front passenger seat’s lap-shoulder belt can be adjusted.

Push the button (1) upward and slide the height adjuster on the top of the belt up and down to suit the occupant height. Release the button (1) at the proper position, pull the seat belt forcibly to ensure that the vertical adjuster is locked reliably.

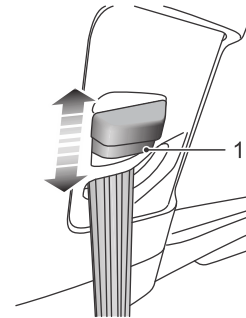

Seat Belt Pretensioner



Do not damage or repair the pretensioner. As it contains the ignition device, so it can only be repaired by our Service Dealer.

The pretensioner will be invalid once being activated, so it must be replaced. Ensure that our Service Dealer has checked and repaired the pretensioners and all seat belt components after the collision.

The seat belt pretensioner works with the airbag to reduce the risk of injury caused by the frontal impact. Refer to "Airbag" in this chapter for more information.

Airbag



None protection device is absolutely safe, when used to avoid the occurrence of serious collision, it may result in the personal injury or death. Even though the seat belt is worn properly and the airbag is inflated, it may also result in the personal injury or death.

When inflated, some components of the airbag will be hot, so do not contact it before cooling down.

Airbag inflation may lead to the occupant facial abrasions or other injuries, such injuries can be minimized only if you and your occupants wear the seat belt.

The driver seat should be adjusted to the back as far as possible without affecting your driving.

Always hold the steering wheel rim, so that the airbag would not be interfered when inflating.

Do not put any accessory (eg. mobile phone holder, cup base, tray) on the steering wheel cover or the airbag cover plate of the instrument panel, also do not paste (or insert) any objects onto the airbag module cover. Otherwise, it will affect the airbag inflation, or these objects will be blown to any area of the interior when the airbag is inflated, resulting in the occupant injury.

BEFORE YOU DRIVE

 For the seat with seat airbag, it is forbidden to set the seat cover or other decorative items that affect the deployment of seat airbag.

Do not modify the seat with seat airbag.

Do not paste any sharp items on the A/B/C/D pillar of the vehicle or modify these pillars to avoid injury to occupants during the operation of airbag.

The occupants must not contact or access to the airbag cover plate of the instrument panel with their foot, knee or other body parts, or it may impede the deployment of the airbag.

The seat belt pretensioner works with the airbag to reduce the risk of injury caused by the frontal impact.

Do not remove or knock the steering wheel violently, also do not punch the steering wheel.

The space between the driver and the airbag deployment area should not be occupied by others, animals or objects. So is the occupant side equipped with airbag.

Do not repair the steering wheel, steering column, any airbag unit, pretensioner component or airbag component surrounded with wiring by yourself, or the airbag may be activated accidentally, resulting in personal injury. Do not modify the front of the vehicle in any way as this may affect the deployment of airbag.

 The disposal of the undeployed airbag on the vehicle exists the potential risk, it should be deployed before the disposal. This operation must be performed by the professionals.

This vehicle can be equipped with the driver airbag, front passenger airbag, front seat side airbag and side curtain airbag.

Note: Both the airbag and the pretensioner are supplementary protection device, while the seat belt is still the main protection device and must be worn during driving.

Caution

- A loud noise may be heard and a little of gases similar to smoke and the dust will be released when the airbag is activated. Such smoke would not be harmful to the health. The dust may cause the skin irritation, so wash the skin area with soap and water.
- For safety reasons, the airbag should be replaced every 10 years, you are recommended to have it replaced by our Service Dealer. The owner has the obligation to inform the buyer about the Notices and Cautions listed above when the vehicle is sold. The original owner is considered to fulfill his/her obligation once these instruction files (see Owner Warranty and Maintenance Manual) are delivered to new owner.

Airbag and Pretensioner Inspection

! If the ignition switch is turned on, the warning light is not turned on or not turned off after 6 seconds, or turned on when driving, it indicates that the airbag pretensioner or the airbag is faulty. Please contact our Service Dealer for service as soon as possible.

Once the ignition switch is turned to the ON position, “Airbag warning light (red)”  will blink for about 6 seconds, indicating that the airbag and the seat belt pretensioner are being checked; after 6 seconds of blinking, the light will go out, indicating that the airbag and the seat belt pretensioner are normal.

Airbag Deployment

In the event of a collision, the airbag control unit monitors the rate of deceleration or acceleration induced by the collision, then determines whether the airbags should be deployed.

Operation of the airbag is not dependent on the vehicle's speed, but on the collision objects, the collision direction, the collision location and the changing rate of the vehicle's speed.

Deployment of the airbag should not be determined by the vehicle's damage severity.

Airbag deployment is virtually instantaneous and occurs with considerable force, accompanied by a loud noise. The deployed airbag, together with the seat belt restraint system, limit the movement of the

driver and the front passenger, thereby reducing the risk of injury to the head and upper torso.

After the deployment, the airbags deflate immediately, which ensures that the driver's forward vision is not obscured.

Note: When it is deployed, some airbag components are hot, so do not contact it before cooling down.

- Schematic Diagram for Deployment Area of Driver and Front Passenger Airbags

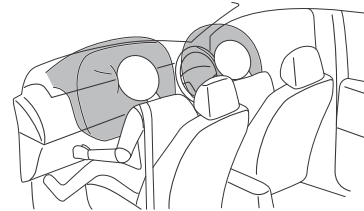

- Schematic Diagram for Deployment Area of Side Airbags and Curtain Airbags

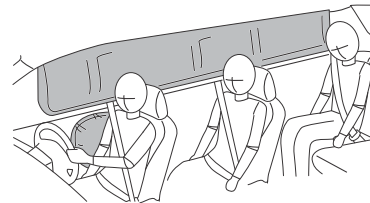

BEFORE YOU DRIVE

Replacement of SRS Components after a Collision

! Collision accidents may damage the SRS on the vehicle. Airbags may not function properly after damage, and can not protect you and other passengers when a collision accident occurs, which may cause the serious personal injury or death. To ensure that SRS can function properly after the collision, please ask our Service Dealer to check and repair the SRS as necessary.

Once the airbag is inflated, the parts of SRS need to be replaced. Please contact our Service Dealer for service as soon as possible.

Child Restraints (not available with the vehicle)

! May result in death or serious injury!
The airbag can kill the children under 12-year old. The backward-facing child or infant restraint device is prohibited being installed on the front seat, otherwise it will result in the serious children or infant injury or death when the airbag is expanded. Seat yourself far away from the airbag as possible as you can.
Observe the instructions provided by the infant or child restraint device's manufacturer if you are installing or using such device.

WARNING: child restraint anchorages are designed to withstand only those loads imposed by correctly fitted child restraints. Under no circumstances are they to be used for adult seatbelts, harnesses, or for attaching other items or equipment to the vehicle.

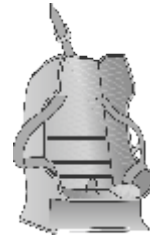

BEFORE YOU DRIVE

Compared with adults, children are more vulnerable by the expanded airbag. So, it is recommended that the children under 12 years old should seat on the rear seat. Generally the babies under 2 years old should use the infant restraints, and the children aged from 2 to 4 years old should use the children restraints. The infant or children restraints are available in the market.

There are various size and types of infant or children restraints, you are recommended to choose the suitable protection device depending on the infants or children's age and weight to achieve the best protection. When making the choices, it is important to note that if this protection device is suitable for your vehicle.

Child Seat Anchor

The three-abreast seat in 2nd row of the vehicle has 4 ISOFIX standard interfaces, and there are also 3 TOP TETHER interfaces on the seat back panel. The individual seat in 2nd row has 2 ISOFIX standard interfaces, and there is also a TOP TETHER interface on the seat back panel. Please observe the instructions provided by the child seat manufacturer for removal and installation.

Installation Methods for Child Seats

1 Route the top tether strap over the seatback and attach to the corresponding child restraint anchorage hook, being careful not to twist the strap. When securing, you must make sure that the top strap passes through the seat headrest (This step only applies to those models with TOP TETHER anchorage). Unless using ISOFIX lower anchorages, use the seatbelt complete the installation in line with the child restraint manufactures instructions.

- 2 Insert the child seat into the ISOFIX retaining ring until it is engaged reliably, the heard "click" sound indicates that it is installed in place.
- 3 When ISOFIX is correctly connected, press down the child seat with your body and tighten the ISOFIX tether to fix the seat firmly on the vehicle.

Caution

It would be best to fix the infant or child restraint device on the rear seat. If the infant or child restraint device must be placed on the front seat when driving, you must use the forward-facing infant or child restraint device. The infant or child restraint device must be fixed correctly regardless of its installation position. Keep in your mind that if the infant or child restraint device is not fixed, it may move and hurt other passengers in the vehicle in the event of collision or sudden braking. Therefore, all infant or child restraint devices must be properly secured in the vehicle even there are no infants or children sitting inside.

BEFORE YOU DRIVE

Type I of 2nd row seat

Front of vehicle

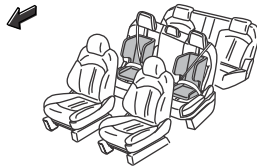

7 seats variant

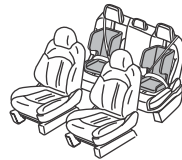

5 seats variant



ISOFIX

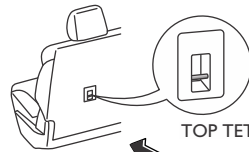

TOP TETHER

Front of vehicle

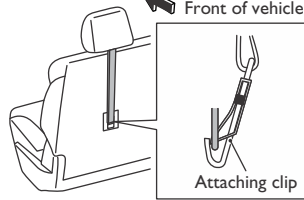

Attaching clip

Type II of 2nd row seat

Front of vehicle

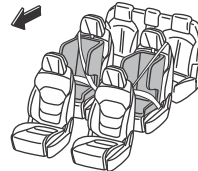

7 seats variant

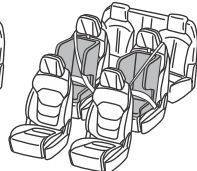

6 seats variant

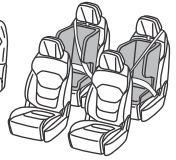

4 seats variant



ISOFIX

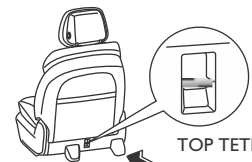
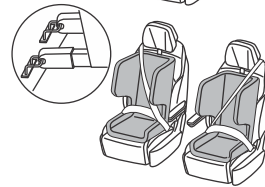

TOP TETHER

Front of vehicle

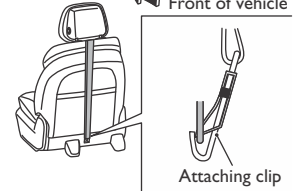

Attaching clip

BEFORE YOU DRIVE

Child seat groups and installation positions

Only the child restraints which are approved and suitable for children are allowed to use. According to AIS072/ECE R44, the child restraint system can be classified as the following 5 groups:

Applicability of child restraints in different seating positions

Mass Group	Seating Position			
	First-row	Second-row left	Second-row Right	Third-row
0 Group (less than 10kg)	X	u	u	X
0+ Group (less than 13kg)	X	u	u	X
I Group (9 - 18kg)	X	u	u	X
II Group (15 - 25kg) X	u	u	X	
III Group (22 - 36kg)	X	u	u	X

Note: The letter filled in the table means
u = Universal child restraint systems which have obtained the approval for this mass group are applicable.
X = Child restraint systems for this mass group are not applicable in this seating position.

BEFORE YOU DRIVE

Adaptability of ISOFIX child restraints in different ISOFIX positions

Mass Group	Size Categories	Fixed Module	ISOFIX Positions on the Vehicle			
			First-row	Second-row Left	Second-row Right	Third-row
Portable Bed	F	ISO/L1	Without ISOFIX Device	IL	IL	Without ISOFIX Device
	G	ISO/L2		IL	IL	
0 Group (Less than 10kg)	E	ISO/R1		IL	IL	
0+ Group (Less than 13kg)	E	ISO/R1		IL	IL	
	D	ISO/R2		IL	IL	
	C	ISO/R2		IL	IL	
I Group (9 - 18kg)	D	ISO/R2		IL	IL	
	C	ISO/R3		IL	IL	
	B	ISO/R1		IUF	IUF	
	B1	ISO/F2		IUF	IUF	
	A	ISO/F3	IUF	IUF		

Note: The letter filled in the table means

IUF = Forward-facing universal ISOFIX child restraint systems which have obtained the approval for this mass group are applicable.

IL = Special ISOFIX child restraint systems on the list are applicable. These restraint systems could be special vehicle type, restricted type or semi-universal type.

Note: For universal and semi-universal child seats, the ISOFIX size categories can be divided into Grade A to G, these classification information can be found on the ISOFIX child seats. The ISOFIX child seats currently recommended for Group 0+ is Britax Romer Baby Safe Plus. The ISOFIX child seats currently recommended for Group I is Britax Romer Duo Plus.

Note: The ISOFIX child seats currently recommended for Group II-III is KidFix XP.

Instruments and Controls

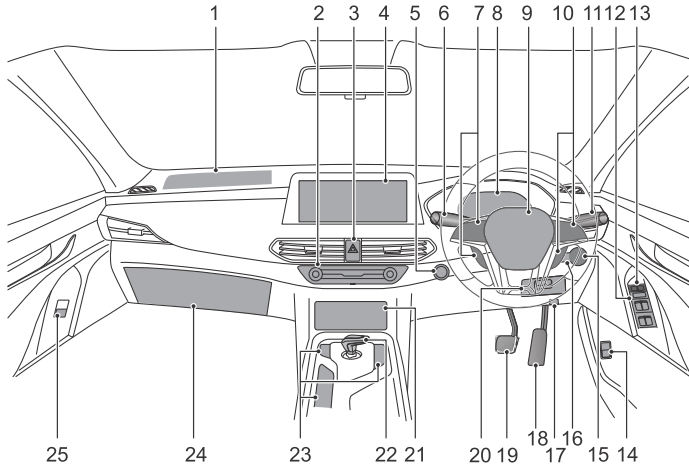

- 1 Front passenger airbag
- 2 A/C control panel
- 3 Hazard warning lamp switch
- 4 Entertainment system
- 5 Ignition switch
- 6 Wiper & washer stalk switch
- 7 Instrument duster selection and cruise switch
- 8 Instrument pack
- 9 Driver airbag
- 10 Voice control, Bluetooth phone and call switch
- 11 Combination lamp control & direction indicator lamp stalk switch
- 12 Door window control switches
- 13 Central lock switch
- 14 Fuel filler flap release switch
- 15 Exterior rearview mirror power adjustment switch
- 16 Instrument panel illumination control switch
- 17 Hood release
- 18 Accelerator pedal
- 19 Brake pedal
- 20 Storage compartment
- 21 Storage compartment
- 22 Shift lever
- 23 Floor console switches
- 24 Glove box
- 25 Front passenger door and window control switch

BEFORE YOU DRIVE

Instrument Cluster

Instrument Cluster Type I

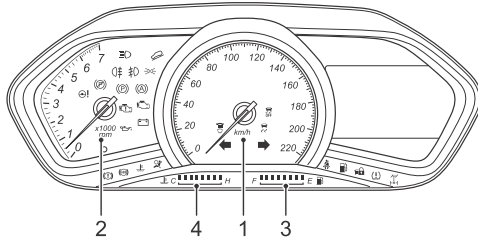

Instrument Cluster Type II

Trip Computer Interface

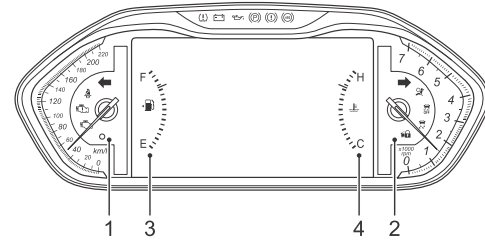

Other Interfaces

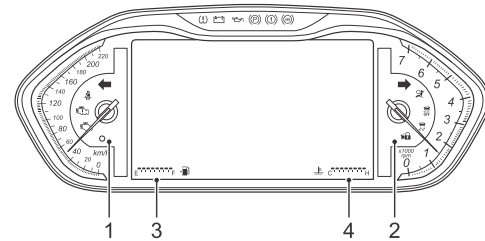

BEFORE YOU DRIVE

- 1 Speedometer
- 2 Tachometer
- 3 Fuel Gauge
- 4 Engine Coolant Temperature Gauge

Caution

Do not place any objects in front of the instrument cluster, so as not to obstruct the dial and warning lamps.

Speedometer

The speedometer displays the vehicle speed in kilometers per hour (km/h).

Caution

According to local laws and regulations, when your vehicle speed exceeds a certain value (eg. 80 or 120 km per hour), the instrument cluster will sound the alarm, please reduce the speed appropriately.

Tachometer

The tachometer indicates the engine speed in revolutions per minute (x1000).

Caution

Never allow the pointer to remain in the red sector of the gauge for prolonged periods, otherwise the engine may be damaged.

Fuel Gauge

Indicates the approximate amount of fuel in the fuel tank. When the "Low Fuel Warning Lamp (yellow)" does not go out or illuminate, please refuel as soon as possible.

Engine Coolant Temperature Gauge

Indicates the approximate temperature of the engine coolant. If the coolant overheats, the "Engine Coolant Temperature Warning Lamp (red)" will illuminate.

Caution

If the red warning lamp illuminates, stop the engine as soon as possible to cool the coolant. Check the engine cooling system.

Information Center

Information Center Type I

The information center display is located at the right side of the instrument cluster.

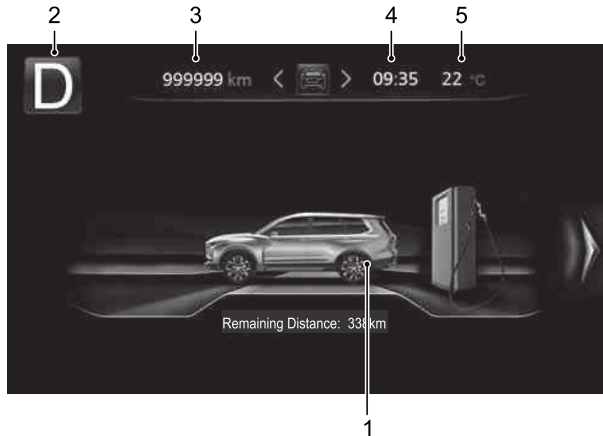

- 1 Trip computer interface
- 2 Gear display
- 3 Total mileage
- 4 Current time
- 5 Ambient temperature

Short press the < or > button in the instrument cluster selection switch  on the steering wheel to achieve the switching of following interfaces: Trip Computer interface » Active Safety interface (when your vehicle is equipped with this function) » Settings interface » Failure Inquiry interface (if a failure is available) » Trip Computer interface.

Trip Computer Interface

Short press the < or > button in the instrument cluster selection switch  on the steering wheel to achieve the switching of following interfaces:

- Driving mileage
 - This function automatically calculates and displays the remaining driving mileage for the vehicle before the fuel is used up. The mileage will change correspondingly after refueling.
- Instantaneous fuel consumption
 - This function automatically displays the instantaneous fuel consumption of currently operating engine.
- Digital vehicle speed
 - It displays the current speed.
- Since the startup
 - Displays the trip, average speed, driving time, average fuel consumption since the ignition switch is turned on.

BEFORE YOU DRIVE

- Since the reset

Displays the trip, average speed, driving time, average fuel consumption since the last reset.

Long press the "OK" button in this interface to reset the trip, average speed, driving time and average fuel consumption.

- Tyre pressure monitoring

In normal mode, it displays the current tyre pressure in real time.

Note: For vehicles equipped with tyre pressure monitoring system, after the tyres are inflated or deflated in static state, when the inflation and deflation is greater than 8kPa, the tyre pressure information display value on the instrument cluster will be updated automatically.



- Battery voltage

Displays current voltage of battery.

- Mileage to next maintenance

This message reminds you of the remaining mileage of your vehicle before the next maintenance.

Settings interface

Short press the  or  button in the instrument cluster selection switch  on the steering wheel to achieve the switching of following interfaces:

- Backlight brightness

You can set the instrument cluster display brightness.

- Time setting

You can set the time on the instrument cluster.

- Time format

You can set the time on the instrument cluster in 12 hour time format or 24 hour time format.

- Language setting (if equipped)

You can set the language based on the actual configuration.

- Overspeed alarm (if equipped)

You can turn on and off the overspeed alarm. When the overspeed alarm is turned on, the overspeed alarm triggering speed value can be adjusted.

Failure Inquiry Interface

You can inquire the relevant vehicle alarm and failure information in this interface.

Information Center Type II

The information center display is located at the right side of the instrument cluster.

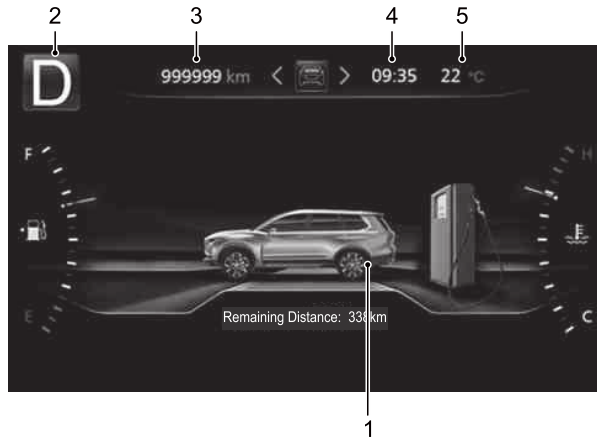

- 1 Trip computer interface
- 2 Gear display
- 3 Total mileage
- 4 Current time
- 5 Ambient temperature

Short press the ◀ or ▶ button in the instrument cluster selection switch  on the steering wheel to achieve the switching of following interfaces: Trip Computer interface » Navigation

Map interface (when your vehicle is equipped with this function) » Multimedia interface » Contacts interface » Active Safety interface (when your vehicle is equipped with this function) » Settings interface » Failure Inquiry interface (if a failure is available) » Trip Computer interface.

Trip Computer Interface

Short press the ▲ or ▼ button in the instrument cluster selection switch  on the steering wheel to achieve the switching of following interfaces:

- Driving mileage

This function automatically calculates and displays the remaining driving mileage for the vehicle before the fuel is used up. The mileage will change correspondingly after refueling.
- Instantaneous fuel consumption

This function automatically displays the instantaneous fuel consumption of currently operating engine.
- Digital vehicle speed

It displays the current speed.
- Since the startup

Displays the trip, average speed, driving time, average fuel consumption since the ignition switch is turned on.

BEFORE YOU DRIVE

- Since the reset

Displays the trip, average speed, driving time, average fuel consumption since the last reset.

Long press the "OK" button in this interface to reset the trip, average speed, driving time and average fuel consumption.

- Tyre pressure monitoring in normal mode, it displays the current tyre pressure in real time.

Note: For vehicles equipped with tyre pressure monitoring system, after the tyres are inflated or deflated in static state, when the inflation and deflation is greater than 8kPa, the tyre pressure information display value on the instrument cluster will be updated automatically.

- Battery voltage

Displays current voltage of battery.

- Mileage to next maintenance

This message reminds you of the remaining mileage of your vehicle before the next maintenance.

Navigation Map interface

It displays the current navigation information.

Multimedia interface

It displays the current listening music radio program information.

Contacts interface



It displays the contacts information.

Active Safety interface

It displays the relevant driver assistant information.

- Adaptive cruise
- Lane departure
- Emergency brake
- Automatic parking

Settings interface

Short press the  or  button in the instrument cluster selection switch  on the steering wheel to achieve the switching of following interfaces:

- Backlight brightness
You can set the instrument cluster display brightness.
- Time setting
You can set the time on the instrument cluster.
- Time format
You can set the time on the instrument cluster in 12 hour time format or 24 hour time format.
- Language setting (if equipped)
You can set the language based on the actual configuration.
- Overspeed alarm (if equipped)
You can turn on and off the overspeed alarm. When the overspeed alarm is turned on, the overspeed alarm triggering speed value can be adjusted.

- Display theme (if equipped)
You can set the instrument cluster theme: comfort/sports.

Failure Inquiry Interface

You can inquire the relevant vehicle alarm and failure information in this interface.

Alarm Messages

Most of the alarm messages will have a corresponding graphic and text description on the instrument cluster. When the message is displayed, the alarm indicator will also illuminate.

If more than one alarm message is activated, the display will show them circularly in the priority sequence, each message will be displayed for 3 seconds.

The priority of alarm messages is higher than that of trip computer information, after the one-touch start switch is turned on, the alarm messages will be displayed first.

Please operate in strict accordance with the instructions in the alarm message, if no relevant instruction is available, please stop the vehicle to check, or consult our Service Dealer.

Important alarm messages

For the currently displayed important alarm message, it can be temporarily hidden by short pressing the "OK" button on the steering wheel or will be automatically hidden after 9 seconds, if the alarm is not canceled, you can view it in the alarm inquiry interface.

If all alarm messages are hidden, the trip computer information will be normally displayed.

After the alarm is canceled, its corresponding alarm message will be canceled at the same time.

Prompt messages

Prompt messages will automatically disappear after 3 seconds.

Caution

Do not ignore the alarm messages, or severe damage to the vehicle may occur. If an alarm indicator illuminates, stop the vehicle as soon as possible while ensuring the safety.

Fatigue driving detection and reminder



Fatigue driving detection and reminder function is to remind drivers not to drive the vehicle at the time of fatigue. The system will record the continuous driving time, while monitoring the steering wheel input in real-time, to identify whether the driver needs to rest.

Fatigue reminder

- During the driving, when the system detects that the steering wheel rotation law meets the fatigue driving conditions, the instrument cluster display will display the following interface, accompanied with voice prompts.



It indicates that the system suggests the driver to take a break, please stop the vehicle for a rest.

BEFORE YOU DRIVE

- During the driving, when the system detects that the continuous driving time exceeds 2 hours and the vehicle speed is higher than 65km/h, the instrument cluster display will display the following interface, accompanied with voice prompts.



It indicates that the system suggests the driver to take a break, please stop the vehicle for a rest.

Caution

- Do not drive the vehicle at the time of fatigue. A driver is always responsible for his driving competence.
- In a long time driving, enough rest needs to be taken at a regular basis.
- The system cannot identify the needs for rest in all cases.

Tyre pressure monitoring system

The tyre pressure monitoring system can conduct real-time automatic monitoring on the tyre conditions, providing an effective safety assurance for driving.

During the driving, when insufficient pressure, excessive pressure, rapid air leakage occur on the tyres or the system the "Tyre Pressure Monitoring System Warning Lamp (yellow)"  on the instrument cluster will illuminate, accompanied with voice prompts, and the instrument cluster display will display the alarm interface.

Overspeed warning

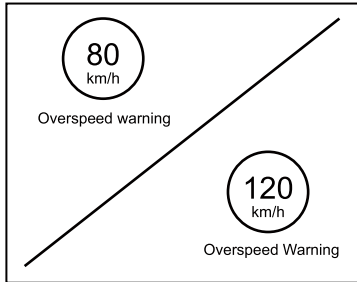

If the vehicle speed is greater than 80 km/h, the meter will make an audible alarm sound. If the vehicle speed is always more than 80 km/h then every two minutes, the alarm will indicate the overspeed driving.

Alarm will stop warning when the speed comes below 75 km/h, then again over 80 km/h, it will be warn for overspeed.

If the vehicle speed is greater than 120 km/h, the alarm will come frequently.

Alarm will stop warning when the speed comes below 115 km/h, then again over 120 km/h, it will be warn for overspeed.

Warning Lamps and Indicators

Direction Indicator



The right or left "direction indicator (green)" blinks when making a turn. The right and left direction indicators blink simultaneously when the hazard warning lamp switch is pressed.

Note: *If either direction indicator is blinking quickly, this indicates that the bulb of turning signal lamp on this side is faulty.*

Front Fog Lamp Indicator



"Front Fog Lamp Indicator (green) illuminates when the front fog lamp is turned on.

Headlamp High Beam Indicator



If the headlamp high beam is turned on or the headlamp is blinking, "Headlamp High Beam Indicator (blue)" illuminates.

Rear Fog Lamp Indicator



"Rear Fog Lamp Indicator (yellow)" illuminates when the rear fog lamp is turned on.

BEFORE YOU DRIVE

Position Lamp Indicator



“Position Lamp Indicator (green) illuminates when the position lamp is turned on.

AFS (Adaptive Front Lighting System) Warning Lamp



When the ignition switch is turned to the ON position, if the "AFS warning lamp (yellow)" stays on, or illuminates during driving, it indicates that the AFS system or headlamp high beam, low beam has a malfunction, please contact our Service Dealer for service as soon as possible.

Airbag Warning Lamp



When the ignition switch is turned to the ON position, "Airbag Warning Lamp (red)" is turned on, the system conducts the self-check and the lamp goes off after several seconds.

If this warning lamp does not illuminate or blinks, stays on, or illuminates or blinks during driving, it indicates that the SRS has a malfunction. Please contact our Service Dealer for service as soon as possible.

Refer to "Airbags" in this section for more information.

Driver and Front Passenger Seat Belt Warning Lamp



When the ignition switch is placed in ON position, "Driver and Front Passenger Seat Belt Warning Lamp (red)" illuminates, the system conducts the self-check and the lamp goes off after several seconds. When the driver or front passenger seat belt is not properly fastened, the "Driver and Front Passenger Seat Belt Warning Lamp (red)" illuminates. When the vehicle speed is greater than 20km/h, the audible warning "seat belt unfastened" will sound, meanwhile the "Driver and Front Passenger Seat Belt Warning Lamp (red)" blinks. After the seat belt is fastened, the "Driver and Front Passenger Seat Belt Warning Lamp (red)" goes out, and the audible warning stops.

Rear Seat Belt Warning Lamp



When the ignition switch is placed in ON position, if the "Rear Seat Belt Warning Lamp (yellow)" is on for a short time, it indicates that the rear seat belt is not properly secured, please fasten your seat belt. When the vehicle speed is higher than 25km/h, the "Rear Seat Belt Warning lamp (yellow)" is on for a short time or flash for a short time and sound a warning, it indicates that the rear seat belt is not property secured, please fasten your seat belt.

Brake System Warning Lamp



When the ignition switch is turned to the ON position, if the parking brake is applied, "Brake System Warning Lamp (red)" illuminates, it will go off once the parking brake is released completely.

When the brake fluid level is below the normal range, "Brake System Warning Lamp (red)" will also illuminate.

If the warning lamp stays on when the parking brake is released, it indicates that the brake system is faulty, stop the vehicle immediately, and contact Service Dealer for service as soon as possible.

If your vehicle is equipped with Electronic Brake Force Distribution (EBD) system, when the ignition switch is placed in ON position, the "Brake System Warning Lamp (red)" illuminates, the system conducts the self-check and the lamp goes out after several seconds. If the warning lamp stays on or illuminates during driving, it indicates that the brake system has a malfunction, please contact Service Dealer for service as soon as possible.

ABS (Anti-lock Brake System) Warning Lamp



When the ignition is turned to the ON position, "ABS warning lamp (yellow)" illuminates, the system conducts the self-check and the lamp goes off after several seconds.

If the warning lamp stays on or illuminates while driving, it indicates that the ABS has a malfunction, please contact Service Dealer for service as soon as possible.

Note: Even if the ABS is faulty, the brake system can still be used for braking (ABS is disabled at this time). Please Refer to "Brake System" in the Starting and Driving section for more information.

EBD (Electronic Brake Force Distribution) Warning Lamp



When the ignition switch is turned to the ON position, "EBD warning lamp (red)" illuminates, the system conducts the self-check and the lamp goes off after several seconds.

If the warning lamp stays on or illuminates during driving, it indicates that the brake system has a malfunction, please contact Service Dealer for service as soon as possible.

ESP (Electronic Stability Program) Indicator Lamp



When the ignition switch is turned to the ON position, "ESP Indicator Lamp (yellow)" illuminates, the system conducts the self-check and the lamp goes off after several seconds.

"ESP Indicator Lamp (yellow)" blinks when the electronic stability program is operating.

If the warning lamp remains on, it indicates that the electronic stability program has a malfunction, please contact Service Dealer for service as soon as possible. Please Refer to "Brake System" in the Starting and Driving section for more information.

ESP (Electronic Stability Program) OFF Indicator Lamp



When the ignition switch is placed in ON position, the "ESP OFF Indicator Lamp (yellow)" illuminates, the system conducts the self-check and the lamp goes out after several seconds.

When the ESP OFF switch is pressed and the ESP is turned off, "ESP OFF Indicator Lamp (yellow)" illuminates. Please Refer to "Floor Console Switches" in this section for more information.

Hill Descent Indicator Lamp



When the Hill Descent is turned on and the operating conditions are met, the "Hill Descent Indicator Lamp (green)" blinks. Refer to "Floor Console Switches" in this chapter for information on the hill descent switch. If the Hill Descent system fails, the "Hill Descent Indicator Lamp (yellow)" illuminates.

Please Refer to "Brake System" in the Starting and Driving section for more information.

Engine Malfunction Warning Lamp



When the ignition switch is turned to the ON position, "Engine Malfunction Warning Lamp (yellow)" illuminates, the system conducts the self-check and the lamp goes off after several seconds.

If the warning lamp illuminates, it indicates that the engine-related parts are faulty. Please contact our Service Dealer for service as soon as possible.

Emission MIL



When the ignition switch is turned to the ON position, "Emission MIL (yellow)" illuminates, and goes off after the engine is started. If the warning lamp illuminates, it indicates that the engine performance and the emission system are faulty. Please contact Service

Dealer for service as soon as possible, meanwhile, avoid the too high engine speed or fast acceleration.

Oil Pressure Warning Lamp



When the ignition switch is turned to the ON position, "Oil Pressure Warning Lamp (red)" illuminates, the system conducts the self-check and the lamp goes off after several seconds. After the engine is started or during the driving, the "Oil Pressure Warning Lamp (red)" illuminates, it indicates that the oil pressure is faulty, please shut down the engine immediately and check the oil level. Refer to "Engine Oil" in the Maintenance and Service chapter.

Caution

Even if the oil level is normal, do not restart the engine, please contact Service Dealer for service as soon as possible.

Engine Immobiliser Warning Lamp



When the ignition switch is turned to the ON position, "Engine Immobiliser Warning Lamp (yellow)" illuminates, the system conducts the self-check and the lamp goes off after several seconds. If the engine immobiliser is authenticated successfully, "Engine Immobiliser Warning Lamp (yellow)" remains dark and the engine can be started.

If the "Engine Immobiliser Warning Lamp (yellow)" blinks, it indicates that the immobiliser control system has a malfunction, the engine can not be started, please contact Service Dealer for service immediately.

Body Theft Deterrent Warning Lamp



When the vehicle is in the armed state, "Body Theft Deterrent Warning Lamp (red)" blinks.

When the vehicle is out of the armed state, "Body Theft Deterrent Warning Lamp (red)" goes off.

If the theft deterrent alarm is triggered, the "Body Theft Deterrent Warning Lamp (red)" blinks, accompanied with audible and visible alarm.

Tyre Pressure Monitoring System Warning Lamp



When the ignition switch is turned to the ON position, "Tyre Pressure Monitoring System Warning Lamp (yellow)" illuminates, the system conducts the self-check and goes off after several seconds. When the tyre pressure monitoring system has a malfunction, "Tyre Pressure Monitoring System Warning Lamp (yellow)" illuminates, please contact Service Dealer for service as soon as possible.

Battery Charging Indicator Lamp



When the ignition switch is turned to the ON position, "Battery Charging Indicator Lamp (red)" illuminates, and goes off after the engine is started.

Caution

If the warning lamp stays on after the engine is started or illuminates during driving, it indicates that the charging system has a malfunction, please contact Service Dealer for service as soon as possible.

Constant Speed Cruise Indicator Lamp



With the ignition switch placed in ON position, when the cruise system is in standby state, the "Constant Speed Cruise Indicator Lamp (white)" illuminates, when the system is in activation state, the "Constant Speed Cruise Indicator Lamp (green)" illuminates. Please Refer to "Constant Speed Cruise Control System" in the Starting and Driving section for more information.

Adaptive Cruise Control Indicator Lamp



With the ignition switch placed in ON position, turn on the adaptive cruise, when the adaptive cruise system meets the activation conditions, the "Adaptive Cruise Control (ACC) Indicator Lamp

(green)" illuminates. When the adaptive cruise control system is in standby mode, the "Adaptive Cruise Control (ACC) Indicator Lamp" on the instrument cluster will change from green to white. Please Refer to "Driver Assistant System" in the Starting and Driving section for more information.

Adaptive Cruise Vehicle-to-Vehicle Distance Indicator Lamp



With the ignition switch placed in ON position, turn on the adaptive cruise, when setting the vehicle-to-vehicle distance, the "Adaptive Cruise Vehicle-to-Vehicle Distance Indicator Lamp (yellow)" illuminates. Please Refer to "Driver Assistant System" in the Starting and Driving section for more information.

4WD Malfunction Warning Lamp



When the ignition switch is turned to the ON position, "4WD Malfunction Warning Lamp (red)" illuminates or illuminates during driving, it indicates that the 4WD system has a malfunction, please contact Service Dealer for service as soon as possible. Please Refer to "Four Wheel Drive (4WD)" in the Starting and Driving section for more information.

Lane Departure Alert Warning Lamp



With the ignition switch placed in ON position, when the lane departure alert is in standby state, the "Lane Departure Alert Warning Lamp (whiter)" illuminates.

When the lane departure alert is in operating state, the "Lane Departure Alert Warning Lamp (green)" illuminates.

When the lane departure alert is in operating state and gives an alarm, the "Lane Departure Alert Warning Lamp (yellow)" blinks.

When the lane departure alert is in off state or has a malfunction the "Lane Departure Alert Warning Lamp (yellow)" illuminates.

If the warning lamp illuminates yellow when the lane departure alert is on, it indicates that the lane departure alert has a malfunction, please contact our Service Dealer for service as soon as possible. Please Refer to "Driver Assistant System" in the Starting and Driving section for more information.

Intelligent Start/Stop System Indicator Lamp



With the ignition switch placed in ON position, turn on the start/stop system, when the start/stop conditions are not met, the "Intelligent Start/Stop System Indicator Lamp (white)"



illuminates.

With the ignition switch placed in ON position, turn on the start/stop system, when the engine automatically stops, the "Intelligent Start/Stop

System Indicator Lamp (green)"  illuminates.

With the ignition switch placed in ON position, turn on the start/stop system, when the start/stop system has a malfunction, the "Intelligent

Start/Stop System Indicator Lamp (yellow)"  illuminates.

Please Refer to "Intelligent Start/Stop System" in the Starting and Driving section for more information.

AUTO HOLD Indicator Lamp



With the ignition switch placed in ON position, turn on the AUTO HOLD, the "AUTO HOLD Indicator Lamp (green)" illuminates; when the AUTO HOLD is activated, the "AUTO HOLD Indicator Lamp (green)" blinks.

AUTO HOLD has the memory capability. When the AUTO HOLD is on, after the driver unbuckles the seat belt, the "AUTO HOLD Indicator Lamp (green)" goes out, but the On state is still memorized by the AUTO HOLD system. When the AUTO HOLD is on, the vehicle speed exceeds 3 km/h and the seat belt is not fastened, the "AUTO HOLD Indicator Lamp (green)" illuminates to remind the driver that the AUTO HOLD On state has been recalled, and the AUTO HOLD can be activated just by fastening the seat belt again. When the AUTO HOLD is

BEFORE YOU DRIVE

on, the vehicle speed is lower than 3 km/h and the seat belt is not fastened, the AUTO HOLD cannot be activated due to unfastened seat belt, and the "AUTO HOLD Indicator Lamp (green)" goes out.

With the ignition switch placed in ON position, turn on the AUTO HOLD, when the AUTO HOLD has a malfunction, the "AUTO HOLD Indicator Lamp (yellow)" illuminates. Please Refer to "Brake System" in the Starting and Driving section for more information.

Electronic Parking Brake (EPB) Indicator Lamp



With the ignition switch placed in ON position, turn on the electronic parking brake, when the parking brake is applied, the "EPB Indicator Lamp (red)" illuminates, and goes out immediately after the parking brake is fully released. Please Refer to "Brake System" in the Starting and Driving section for more information.

Electronic Parking Brake (EPB) Malfunction Indicator Lamp



When the ignition switch is turned to the ON position, "EPB Malfunction Indicator lamp (yellow)" illuminates, the system conducts the self-check and the lamp goes off after several seconds. If the "EPB Malfunction Indicator Lamp (yellow)" illuminates after the electronic parking brake is released, it indicates that the brake system has a malfunction, please stop the vehicle immediately, and contact our Service Dealer for service as soon as possible.

Please Refer to "Brake System" in the Starting and Driving section for more information.

Electric Power Steering (EPS) System Failure Warning Lamp



With the ignition switch placed in ON position, the "EPS System Failure Warning Lamp (red)" illuminates, it indicates that the EPS system has a malfunction, please stop the vehicle immediately, and contact our Service Dealer for service as soon as possible.

Front Collision Warning (FCW) / Automatic Emergency Braking (AEB) Warning Lamp



With the ignition switch placed in ON position, when the front collision warning system is operative, and the automatic emergency braking warning system does not give a warning, the "FCW/AEB Warning Lamp (yellow)" blinks; with the ignition switch placed in ON position, when the automatic emergency braking warning system gives a warning, the "FCW/AEB Warning Lamp (red)" illuminates. Please Refer to "Driver Assistant System" in the Starting and Driving section for more information.

BEFORE YOU DRIVE

Ahead Vehicle Indicator Lamp



With the ignition switch placed in ON position, when any of the ACC/FCW/AEB is turned on, and a vehicle within the front monitoring distance is detected, the "Ahead Vehicle Indicator Lamp (green)" illuminates. Please Refer to "Driver Assistant System" in the Starting and Driving section for more information.

Electronic Differential Lock Indicator Lamp

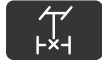



With the ignition switch placed in ON position, press the differential lock switch, when the electronic differential lock is successfully locked, the "Electronic Differential Lock Indicator Lamp (yellow)" illuminates.

With the ignition switch placed in ON position, the "Electronic Differential Lock Indicator Lamp (red)" illuminates, it indicates that the electronic differential lock system has a malfunction, please stop the vehicle immediately, and contact our Service Dealer for service as soon as possible. Please Refer to "Electronic Differential Lock (EDL)" in the Starting and Driving section for more information.



ECO Indicator Lamp



Turn the ignition switch to ON position. For models with the ECO mode switch, press the ECO switch, "ECO Indicator Lamp (green)" turns on; for models with the driving mode switch , press the  switch once, and the "ECO Indicator Lamp (green)" turns on.

SPORT Indicator Lamp



Turn the ignition switch to ON position. For models with the SPORT mode switch, press the SPORT switch, "SPORT Indicator Lamp (green)" turns on; for models with the driving mode switch , press the  switch twice, and the "SPORT Indicator Lamp (green)" turns on.

Fuel Filter Water Level Warning Lamp



when the ignition switch is turned to the ON position, if the "Fuel Filter Water Level Warning Lamp (yellow)" illuminates during driving, stop the vehicle as soon as possible and drain the water from the fuel filter. If not the engine will limit torque. Refer to "Water Draining of Fuel Filter" in the Treatments to Emergency Fault for the information on the water draining of the fuel filter.

Glow Plug Indicator



When the ignition switch is turned to the ON position, if the "Glow Plug Indicator (yellow)" goes off when the preset time elapsed, it indicates that the engine can be started.

Caution

If the indicator stays on after the engine is started, please contact Service Dealer for service as soon as possible.

DPF (Diesel Particulate Filter) Warning Lamp



Turn the ignition switch to ON position. When the "DPF Warning Lamp (yellow)" is always on, Level 1 alarm of the diesel particulate filter is prompted, indicating that the DPF tends to be overloaded. Drive the vehicle at high speed (vehicle speed more than 60 km/h) for about 20 minutes when safe and legal, or stop it in a safe environment and press the DPF one-touch regeneration switch in the armrest box for regeneration in situ; when the DPF warning lamp flashes, Level 2 alarm of the diesel particulate filter is prompted, indicating that the particulate filter is clogged and automatic regeneration cannot be performed. Please stop the vehicle in a safe environment and press the DPF one-touch regeneration switch in the armrest box for regeneration. Refer to "Catalytic Converter" in "Starting & Driving" section for details.

Urea Warning Lamp





When the ignition switch is turned to ON position and the "Urea Warning Lamp (yellow)" flashes slowly, the buzzer sounds for three consecutive times, indicating that the urea level is low, and the instrument pack will indicate the remaining mileage supported by the urea tank, please refill urea as soon as possible; when the urea warning lamp flashes quickly, the buzzer will sound for three consecutive times, indicating that the urea level is low, the instrument pack will indicate that the urea tank level is low, and the vehicle cannot be started after driving XX kilometers, please refill urea as soon as possible; when the warning lamp stays on, the buzzer sounds for three consecutive times, indicating that the urea solution is empty, the instrument pack will indicate that the urea tank is empty, and the vehicle cannot be started, please refill urea (it is required to be refilled to a level that can travel over 800 kilometers). When the urea system fails, the warning lamp will also stay on, the buzzer sounds for three consecutive times, and the instrument pack will prompt the cause of the failure. At this time, please contact Service Dealer for service as soon as possible.

Instrument Panel Switch

Instrument panel illumination control switch

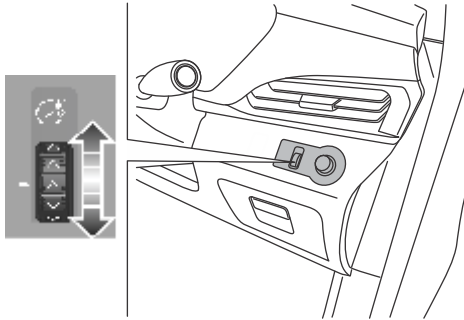
The instrument panel illumination control switch is located on the instrument panel at driver side.



Adjust the instrument panel illumination brightness with the instrument panel illumination control thumbwheel switch .

Move the thumbwheel switch  up/down to brighten or dim the illumination lamp.

Adaptive Front-lighting System

If your vehicle is equipped with AFS (Adaptive Front-lighting System), the system automatically adjusts the headlamp beam height according to the driving speed, vehicle load and ramp angle.

When driving with passengers or luggages carried, the headlamp beams are automatically adjusted up or down.

Note: The headlamp aiming is very important for safe driving. If an adaptive front-lighting system failure occurs, please contact our Service Dealer for service as soon as possible.

Hazard warning lamp switch

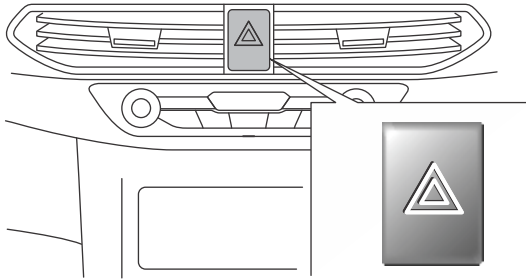



Press the hazard warning lamp switch  to activate all turning signal lamps meanwhile, and the "direction indicator lamp (green)" on the instrument cluster will illuminate and flash. Then press this switch to turn off the above lamps.

Note: Turn on hazard warning lamps to prompt other vehicles that your vehicle has a malfunction and approaching your vehicle may be dangerous.

Floor Console Switches

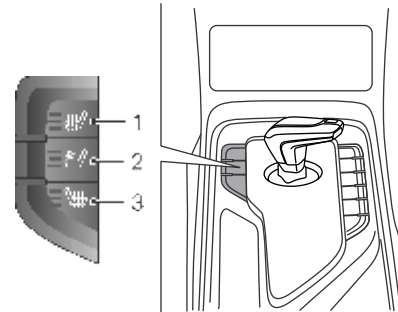
Switch group in left front side of the shift lever



Position 1-  : Driver seat heating. There are three gears for driver seat heating. Press down the switch (1) to start up the driver's seat heating; at the moment, the third heating gear (3 indicator lamps) will be engaged. Press down the switch (1) in turn to shift the driver's seat heating gear accordingly to the second heating gear (2 indicator lamps), the first heating gear (1 indicator lamp), and its function turn off.

Position 2-  : Driver's seat ventilation. There are three gears for driver's seat ventilation. Press down the switch (2) to start up the driver's seat ventilation; at the moment, the third ventilation gear (3 indicator lamps) will be engaged. Press down the switch (2) in turn to shift the driver's seat ventilation gear accordingly to the second

BEFORE YOU DRIVE

ventilation gear (2 indicator lamps), the first ventilation gear (1 indicator lamp), and its function turnoff.

Position 3-: Passenger seat heating. There are three gears for passenger seat heating. Press down the switch (3) to start up the passenger seat heating; at the moment, the third heating gear (3 indicator lamps) will be engaged. Press down the switch (3) in turn to shift the passenger seat heating gear accordingly to the second heating gear (2 indicator lamps), the first heating gear (1 indicator lamp), and its function turn off.

Switch group in left rear side of the shift lever

Type I

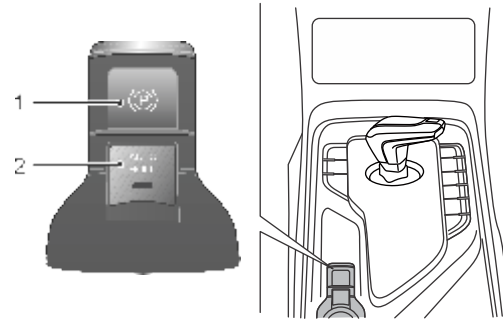

Position 1 -  : EPB (electronic parking brake) switch.

Position 2 -  : AUTO HOLD (auto-hold automatic parking) switch. Press down the button to light up its indicator lamp.

Note: Please refer to “Brake System” in the Starting and Driving section for more information.

BEFORE YOU DRIVE

Type II

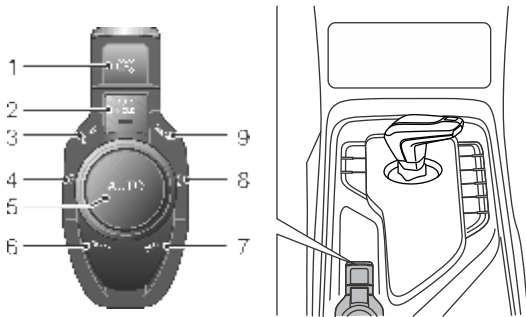

Position 1- Ⓞ: EPB (electronic parking brake) switch.

Position 2- AUTO HOLD: AUTO HOLD (auto-hold automatic parking) switch. Press down the button to light up its indicator lamp.

Note: Please refer to "Brake System" in the Starting and Driving section for more information.

Position 3-SPORT: Sport mode switch. Press down this switch to drive the vehicle under the sport mode, under which the engine power will be relatively strong.

Position 4-ECO: Economic mode switch. Press down this switch to drive the vehicle under the economic mode, under which the engine power will be relatively weak.

Position 5-AUTO: Automatic mode switch.

Position 6- ROCK: Rock mode switch.

Position 7- SAND: Sand mode switch.

Position 8- MUD: Mud mode switch.

Position 9- SNOW: Snow mode switch.

Note: Please refer to "Four Wheel Drive (4WD)" in the Starting and Driving section for more information.

Switch group in right side of the shift lever

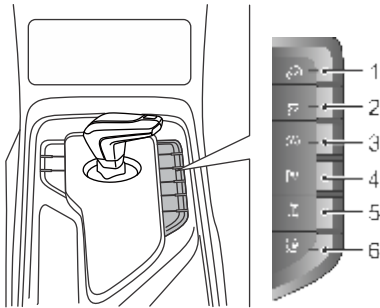

Position 1 - : Hill Descent Control switch. Press the switch (1), and the indicator lamp in the switch illuminates and the hill descent control function is enabled; press the switch (1) again to disable the function; for more information, please refer to “Brake System” in the Starting and Driving section.

Position 2 - : ESP OFF switch. Press the switch (2), and the indicator lamp in the switch illuminates and the ESP system is turned off; press the switch again to enable the ESP system; after the ESP system is turned off, only ABS and EBD functions can work; for more information, please refer to “Brake System” in the Starting and Driving section.

Position 3 - : Engine Intelligent start/stop system switch. With the ignition switch placed in ON position, the engine intelligent start/stop system will be turned on by default while the indicator lamp in the switch

will light up. Press the switch (3) to go out its indicator lamp and turn off the engine intelligent start/stop system; re-press the switch to turn on the system. For more information, please refer to “Intelligent Start/Stop System” in the Starting and Driving section.

Position 4 - : Automatic parking switch.

Note: For more information, please refer to “Intelligent Semi-Automatic Parking Assist System” in the Starting and Driving section.

Position 5 - : Electronic differential lock control switch. Use electronic differential lock control switch to select the differential lock On/Off state with the EDL switch. Please refer to “Electronic Differential Lock (EDL)” in the Starting and Driving section for more details.

Position 6 - : Lane departure alert switch. With the ignition switch placed in ON position, the lane departure alert will be turned on by default while the indicator lamp in the switch will illuminate. Press down the switch to turn off the lane departure warning; and then the indicator lamp on the switch will go off while the “Lane Departure Alert Warning Lamp” on the combination instrument will be lightened in yellow. Re-press the button to enable the lane departure alert. For more information, please refer to “Driver Assist System” in the Starting and Driving section.

Switches on Steering Column and Steering Wheel

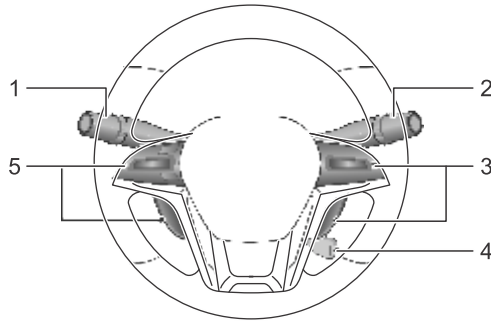

- 1 Wiper & washer stalk switch
- 2 Combination lamp control & direction indicator lamp stalk switch
- 3 Voice control, Bluetooth phone and lcall switch
- 4 Ignition switch and steering lock
- 5 Instrument cluster selection and cruise switch

Combination lamp control & direction indicator lamp stalk switch

Lighting control switch

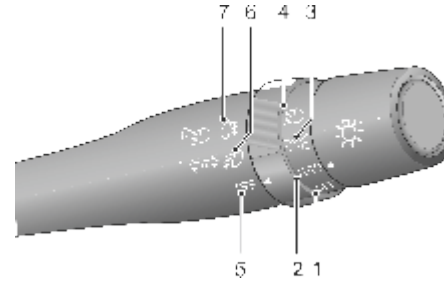

Shift the lighting control switch to the position as shown in the figure, and the corresponding lamps will illuminate.

Position 1 — OFF: Headlamps off. Daytime running lamps will automatically illuminate after the engine is started.

Position 2 — AUTO: Headlamp automatic adjustment. When the headlamp switch is placed in AUTO position, headlamps will illuminate/go off according to the lighting brightness of ambient environment. Daytime running lamps will automatically illuminate when other lamps are not turned on after the engine is started.

Note: *Initial position of headlamp switch is suggested to AUTO position.*

BEFORE YOU DRIVE





Position 3 - : Width lamps on. When width lamps are turned on, the following lamps will be turned on meanwhile:





- Width lamps
- License plate lamp
- Instrument panel lamp

Position 4 - : Headlamps on.

Note: Headlamps can be turned on only when the ignition switch is placed in ON position. If headlamps are not turned off when the vehicle is parked, battery will discharge. Then the engine may be unable to start due to low battery. When the ignition switch is placed in LOCK position or the key is pulled out, there will be warning sounds if the headlamp switch is still turned on.

Position 5 - OFF: Fog lamp off.

Position 6 - : Front fog lamps on. When the ignition switch is placed in ON position and the lighting control switch is placed in  or  position, turn the switch to , and then front fog lamps will be turned on. When the lighting control switch is placed in AUTO position, and the switch is rotated to  position, the front fog lamps may illuminate and go out with the headlamp according to the ambient circumstances. When the front fog lamps are turned on, the "front fog lamp indicator lamp (green)" on the instrument cluster will illuminate.

Position 7 - : Rear fog lamps on. When the ignition switch is placed in ON position and the lighting control switch is placed in  or  position, turn the switch to  and then rear fog lamps will be turned

on. When the lighting control switch is placed in AUTO position, and the switch is rotated to  position, the rear fog lamps may illuminate and go out with the headlamp according to the ambient circumstances. When the rear fog lamps are turned on, the "rear fog lamp indicator lamp (yellow)" on the instrument cluster will illuminate.

Note: Rear fog lamps shall not be used until the visibility is obviously restricted (such as heavy fog or snow).

Turn signal lamps and direction indicator lamps

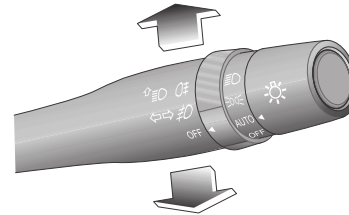

Turn right - push the stalk switch downwards.

Turn left - pull the stalk switch upwards.

Then the corresponding turn signal lamp and the "direction indicator lamp (green)" on the instrument cluster will illuminate simultaneously.

High beam and low beam lamps

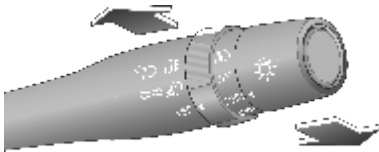

Push the stalk switch away from the steering wheel to change the headlamp mode from low beam to high beam. Pull the stalk switch close to the steering wheel to change the headlamp mode to low beam.

Note: *When the headlamp mode is high beam, the “headlamp high beam indicator lamp (blue)” on the instrument cluster will illuminate. To shift the headlamp mode to flashing, slightly lift the stalk switch towards the steering wheel intermittently.*

Daytime running lamp

The daytime running lamp make it easier for others to see the front of the vehicle during the daytime.

If your vehicle is equipped with the daytime running lamp, when the ignition switch is placed in ON position, the day time running lamp will illuminate. When the day time running lamp illuminates, the low beam, tail lamp, position lamp and other lamps will not illuminate. When the ignition switch is in OFF position, the day time running lamp will go out.

It is in line with the requirements in ECE R87 for daytime running lamp.

Wiper & washer stalk switch

Front windshield wipers and washer

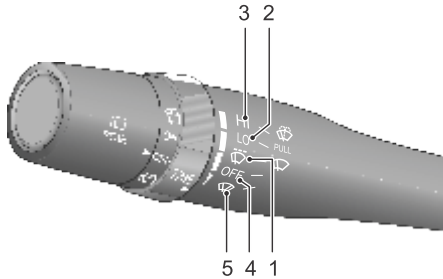

Place the stalk switch to the position required.

Position 1 - : Intermittent wiping. For a vehicle equipped with an automatic wipers, its rain sensor will detect the rainfall on the windshield and automatically adjust the wiping frequency of windshield wipers.

Note: Ensure the rain sensor is free of dust, dirt and ice.

Position 2 - LO: Low-speed wiping.

Position 3 - HI: High-speed wiping.

Position 4 - OFF: Turn off wipers.

Position 5 - : Single wiping.

Intermittent wiping/interval adjustable

 If worn wiper blades cannot clear rain from the front windshield, the forward visibility will be lowered, which may lead to an accident. Be sure to replace worn wiper blades in time.

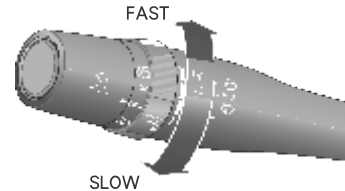

For vehicles not equipped with a rain sensor, when the stalk switch is placed in  (Intermittent) position, rotate the switch to change the wiping interval.

For vehicles equipped with a rain sensor, when the stalk switch is placed in  (Intermittent) position, rotate the switch to change the wiper sensitivity, and adjust the wiping speed of the front wipers.

BEFORE YOU DRIVE

Caution

In cold or hot days, in order to prevent damaging wipers, please clear barriers from the windshield (such as snow) if wiper blades are frozen or adhere to the windshield. Do not operate wipers when leaving the windshield dry. Otherwise the windshield may be damaged, wiper blades may be worn prematurely, and the driver's vision may be affected.

Washer

Pull the stalk switch towards the steering wheel, and the washer will start operating immediately. After a transient interval, wipers and washer will operate in linkage. The washer will be turned off after the stalk switch is released.

Note: After the stalk switch is released, wipers will continue conducting wiping operations for 3 times.



Rear window wipers and washers

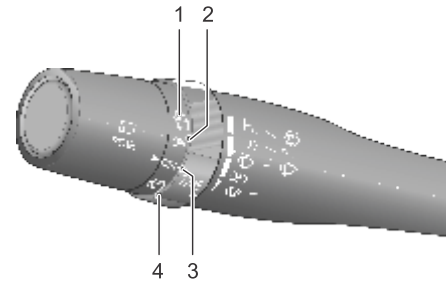

Rotate the stalk switch to the desired position.

Position 1, 4 - : washers spraying water and wipers running.

Position 2 - ON: normal wiper running.

Position 3 - OFF: wiper off.

Instrument cluster selection and cruise switch

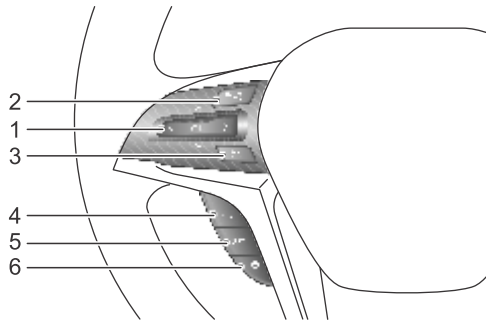

Position 1 —  : instrument cluster selection button. Press up, down, left and right to enter the instrument cluster for page up, down, left and right, and press the OK button to confirm the selection.

Constant speed cruise control system

Position 2-  : Cruise on/off switch. Press this button to turn on/off the cruise control system. The "Constant Speed Cruise Indicator Lamp" on the instrument cluster will illuminate or go out.

Position 3-  : Cruise cancel switch. Press this button to cancel the cruise function without clearing the set speed in the memory.

Position 4 - RES+ : Cruise recovery/acceleration switch. To store the set speed, press this button to recover this speed. Press this button again to accelerate (1 km/h per time).

Position 5- SET- : Cruise setting/deceleration switch. Press this button to set the speed. Then the cruise function will be enabled and the "Constant Speed Cruise Indicator Lamp" on the instrument cluster will turn green from white. If the cruise function is enabled at this time, press this button to lower the cruise speed (1 km/h per time).

Note: Please refer to "Constant Speed Cruise Control System" in the starting and Driving section for more description about cruise function.

BEFORE YOU DRIVE

Adaptive Cruise Control (ACC)

Position 2 - : Adaptive cruise master switch, press it to turn the system on or off.

When the ACC is On:

Position 3 - : It is the adaptive cruise exit switch, press it to disable the adaptive cruise control, but do not clear the set cruise speed.

Position 4 - RES+: Increase the stored speed or re-activate the adaptive cruise control and resume the stored speed.

Position 5 - SET-: Decrease the stored speed or activate the adaptive cruise control and store the current speed.

Position 6 - : Vehicle-to-vehicle distance setting, adjust the vehicle-to-vehicle distance of the adaptive cruise control, the vehicle-to-vehicle distance will be cycled among level 1 - 3 by each press.

Note: Please refer to "Driver Assistant System" in the Starting and Driving section for more description about cruise function.

Voice control, Bluetooth phone and lcall switch

Type I

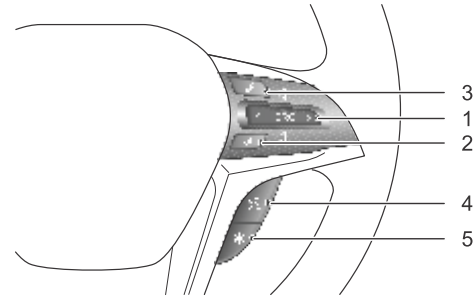

Type II

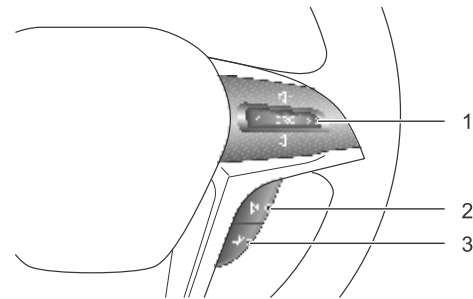



Position 1 - SRC: Audio source switch. Press SRC to switch between the radio and MP3 playback interfaces, press up to increase the volume, press down to decrease the volume; short press <, switch to previous band/MP3 track, long press <, fast rewind; short press >, switch to next band/MP3 track, long press >, fast forward.

Position 2- Mute switch.

Position 3 - Bluetooth phone switch. When Bluetooth is connected, this button is the Bluetooth phone answering switch. In the general calling state: In case of an incoming call, short press this button to answer; long press this button to hang up; during a call, short press this button to hang up. In the call waiting state: Short press this button to hang up the call waiting; long press this button to answer the call waiting.

Position 4- Voice dialogue system switch. Press this button to enable voice recognition function; press this button to disable voice recognition function.

Position 5- * : Icall switch.

Steering Wheel Adjustment

! Do not adjust the steering wheel position during driving. This is extremely dangerous.

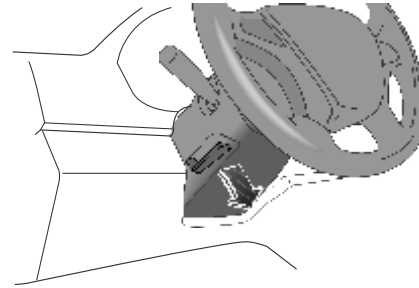

Adjust the steering wheel position to adapt to your driving posture through the following steps:

- 1 Fully release the steering wheel adjusting handle on the steering column downwards;
- 2 Grasp the steering wheel firmly with both hands, and move the steering wheel upwards or downwards, backwards or forwards to adjust it to a proper position;

Note: If it is still difficult to move the steering wheel to a proper position, place the ignition switch in ON position to unlock the steering wheel, and turn the steering wheel to the straight forward position.

BEFORE YOU DRIVE

Note: *The type of the steering wheel that can be adjusted depends on the actual configuration of your vehicle.*

- 3 Select a proper driving position, and pull the steering wheel adjusting handle fully up to lock the steering wheel into its new position.

Horn

Regardless of the ignition switch position, the horn can work once you press the button.

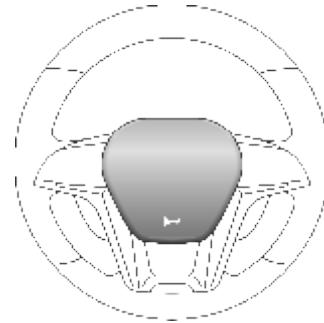

Heating, Ventilation and Air Conditioning

The air conditioning system can cool down the air and remove the moisture and the dust (e.g., pollen) in the air.

The heating system utilizes the heat generated by the engine, so it can heat the air in the vehicle sufficiently only when the engine gets to the normal operating temperature.

The ventilation system ensures the interior ventilation when driving.

The front and rear A/C air volume selection buttons control the air volume.

HVAC is used to control the cooling, heating and ventilation of the air inside the vehicle. Fresh air is drawn into the vehicle through the air intake grille under the windshield, and flowing through the air conditioning filter. Always keep the air intake grille clean, free of obstructions such as leaves, snow or ice.

Front vents

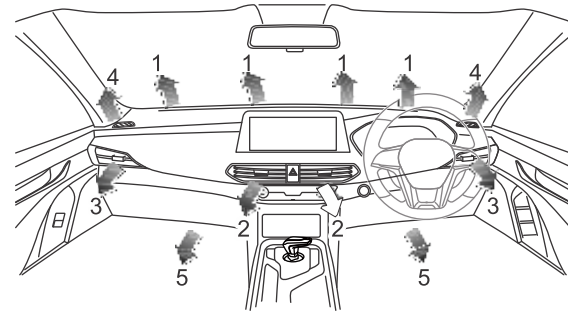

- 1 Windshield vent
- 2 Central vent
- 3 Side vent
- 4 Front window vent
- 5 Front feet vent

BEFORE YOU DRIVE

Central vent

Move the lever (1) in the center of the grille up and down, right and left to change the direction of the air distribution.

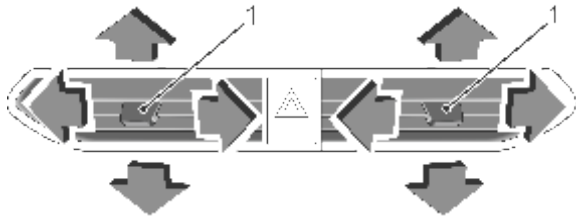

Rear vent

Turn the grille or move the lever (1) in the center of the grille to change the direction of air distribution. There are 4 ceiling vents, 2 on each side.

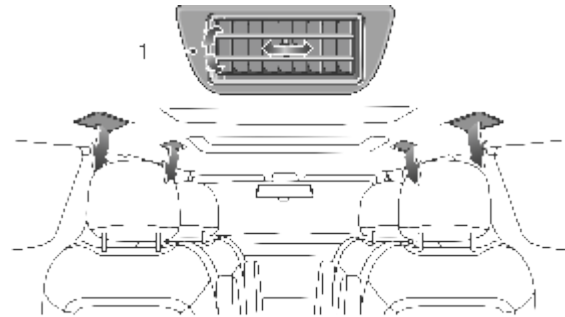

Side vent

Move the lever in the center of the grille up and down, right and left to change the direction of the air distribution.

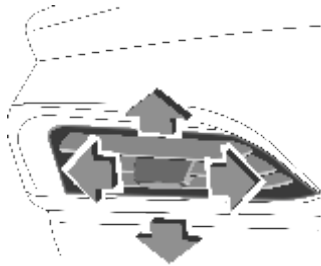

Automatic A/C Front Control Panel

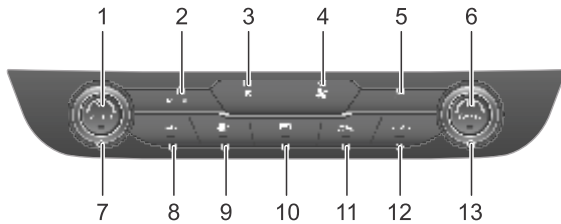

- 1 AUTO button
- 2 MODE button
- 3 Front A/C air volume - selection button
- 4 Front A/C air volume + selection button
- 5 OFF button
- 6 SYNC button
- 7 Left temperature selection knob
- 8 A/C button
- 9 Front defrost button
- 10 Rear defrost button
- 11 Internal/external circulation button
- 12 Rear A/C control button
- 13 Right temperature selection knob

AUTO button

This is the automatic air conditioning control mode button.

Press the AUTO button to enter the full AUTO state, each control will enter the automatic working state, the AUTO indicator illuminates, in the full AUTO state, press the AUTO button again to disable it.

In the AUTO state, operate the MODE, air volume, A/C buttons, the panel will exit the full AUTO state, the AUTO indicator goes out, and the relevant functions enter the manual control state, while other functions that are not operated remain in auto control.

In the AUTO state, operate the temperature control knob, the panel still remains in the full AUTO state, and the AUTO indicator stays on.

In the AUTO state, operate the internal/external circulation button, the relevant functions enter in the manual control state, the AUTO indicator stays on, while other functions that are not operated remain in auto control.

In the AUTO state, operate the front defrost button, the A/C enters the front defrost state, and the AUTO indicator goes out.

MODE button

Adjust the air distribution mode. If MODE button is pressed in the ON state, A/C will switch to the Distribution to Face, Distribution to Face and Feet, Distribution to Feet, Distribution to Feet and Defrost mode in turn, and the infotainment display will display the information about the related air distribution mode.

The operation of MODE is invalid in the OFF state, the mode will recover the non-defrosting mode memorized before powered off.

MODE button can be operated to switch the modes in AUTO state, while the mode control will change to the manual control from AUTO control, the AUTO indicator goes off and other features maintain in AUTO state.

Front A/C air volume selection button

There are 2 front A/C air volume selection buttons: the air volume + button and air volume - button. there are totally 8 air volume levels, the air volume indication is displayed on the entertainment system large-screen display.

The air volume of A/C increases by one level once the air volume + button is pressed; the air volume decreases by one level once the air volume- button is pressed.

When the air volume + button is pressed more than 1 seconds, the volume increases to the top level slowly; When the air volume - button is pressed more than 1 seconds, the volume reduces to the minimum level slowly.

If the air volume + or - button is pressed in OFF state, the system starts, the volume level indicator shows the level before power off directly, the air volume slowly increases to this level from level one and other function maintains the non-defrosting state last activated before powered off.

OFF button

When the panel is in the working state, press the OFF button, the A/C panel enters the off state, the A/C output is closed, the air volume is 0, the mode motor, heating and cooling motor, and internal and external circulation motor stop after running to the target position.

In the off state, it can be turned on by operating the AUTO mode button, the front defrost button, the A/C button and the air volume adjusting button.

If the engine stalls, the A/C control panel will memorize the power state before stalling, when the vehicle is powered on again, this panel will go back to the non-defrosting mode last activated before stalling.

In the off state, the internal/external circulation indicator lamp, the rear defrost indicator lamp on the panel indicate their current state, and other indicator lamps go out.

SYNC button

The SYNC button is the button to switch the synchronization and asynchronization of front A/C left and right dual zones.

The indicator lamp On indicates the single zone mode, while the indicator lamp Off indicates the dual zone mode.

When the SYNC indicator lamp is on, the user may operate the temperature setting knob at driver side to adjust the temperature at the front passenger side, so that the set temperature at driver side and front passenger side changes synchronously.

When the SYNC indicator lamp is off, the user may adjust the set temperature at driver side or front passenger side without affecting each other.

Temperature Selection Knob

Adjust the A/C set temperatures at driver side or front passenger side.

The temperature selection knob can be rotated and adjusted within 360°, if it is rotated counterclockwise, the set temperature is reduced; if it is rotated clockwise, the set temperature is rising. The set temperature range is LO, 18°C - 32°C, HI, the temperature increment is 1°C if it is rotated one grade, and this set temperature will be displayed on the infotainment display. LO indicates MAX cooling, HI indicates MAX heating.

The first power-on temperature (factory configuration) is the middle level, and the corresponding LCD display is 25°C.

The temperature value will be memorized at the time of shutdown.

A/C Button

Switch on and off the compressor.

If A/C button is pressed regardless of Power OFF or ON, the corresponding indicator comes on and the infotainment display shows the A/C startup information, and the compressor is activated (vehicle is started); if the A/C button is pressed a second time, the A/C button indicator goes off and the compressor is turned off.

A/C is controlled automatically in AUTO mode, and it changes to the manual control from AUTO control by operating the A/C button, then AUTO indicator goes off, other features maintain in AUTO mode.

Front Defrost Button

Adjust the air distribution mode to Front Defrost.

If the Front Defrost button is pressed in OFF or ON state, the corresponding indicator comes on and MAX defrost is shown on the infotainment display. The volume level increases to the 6th level slowly with the automatic system control, the external circulating air enters into the vehicle, A/C is turned on and the blower air distribution mode is the maximum defrost. However, the internal/external circulation mode, the air volume and A/C are adjustable.

In Front Defrost state, if the Front Defrost button or MODE button is pressed a second time, the front defrost function is turned off, the front defrost indicator goes off and the system returns to the previous state before the front defrost. If the previous state is OFF, it will return to the non-defrosting state before powered off.

Rear Defrost Button

Switch on the rear defrost state. Rear defrost can be activated only when the ignition switch is turned to On position. The operation of the Rear Defrost button will not change another air conditioning states regardless of power on or off, meanwhile the corresponding indicator and the rear defrost information on the infotainment display vary according to the rear defrost state (vehicle is started).

BEFORE YOU DRIVE

For vehicles equipped with the heated exterior rearview mirror, press the Rear Defrost Button to activate the heated exterior rearview mirror, to help clear the fog or frost on the surface of rearview mirror.

Note: The rear defrost will stop after operating for 15 minutes, and its indicator goes off.

Internal/External Circulation Button

Switch between the internal and external circulation with the button, when the internal circulation indicator lamp illuminates, it indicates that it is in internal circulation, when the indicator lamp goes out, it indicates that it is in external circulation. when it is in the defrost mode, switch to external circulation forcibly, then you can switch back to internal circulation manually.

Rear A/C control button

When the ignition switch is in ON position, the REAR button can make adjustments. Press the button, the indicator lamp illuminates, which indicates that the front A/C panel can control the rear A/C, at this time, the adjustments made with the mode, air volume, temperature (left or right), AUTO, OFF buttons on the front A/C panel are to adjust the relevant information of rear A/C, if a rear occupant operates the rear A/C control panel at the time, the signal firstly received in 100ms will be executed; press the REAR button again, the indicator lamp goes out, which indicates that the front A/C control panel resumes its control on the front A/C, and the rear A/C can only be adjusted with the rear A/C control panel.

If the REAR indicator is On, after the passenger stops regulating the front A/C panel for 8 seconds, the indicator automatically goes out, and the front A/C panel will resume its control on the front A/C.

Electronic A/C front control panel

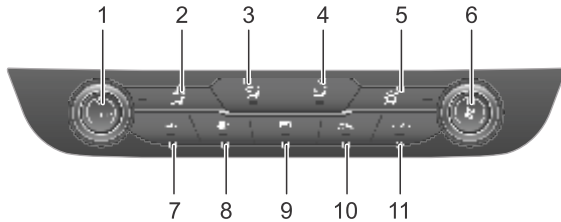

- 1 Temperature selection knob
- 2 Distribution to Face mode button
- 3 Distribution to Face and Feet mode button
- 4 Distribution to Feet mode button
- 5 Distribution to Feet and Defrost button
- 6 Air volume adjusting knob
- 7 A/C button
- 8 Front defrost button
- 9 Rear defrost button
- 10 Internal/external circulation button
- 11 Rear A/C control button

Temperature selection knob

Adjust the A/C set temperature.

The temperature selection knob can be rotated and adjusted in 15 levels, if it is rotated counterclockwise, the set temperature is gradually reduced; if it is rotated clockwise, the set temperature is gradually rising.

Distribution to Face mode button

Adjust the air distribution mode to Distribution to Face. In the ON state, if the Distribution to Face mode button is pressed, the corresponding indicator comes on and it becomes the Distribution to Face mode, the operation of the Distribution to Face mode button is invalid at this time, and it will change to other modes if another mode button is pressed.

Distribution to Face and Feet Mode Button

Adjust the air distribution mode to Distribution to Face and Feet. In the ON state, if the Distribution to Face and Feet Mode button is pressed, the corresponding indicator comes on and it becomes the Distribution to Face and Feet Mode, the operation of the Distribution to Face and Feet Mode button is invalid at this time, and it will change to other modes if another mode button is pressed.

Distribution to Feet Mode Button

Adjust the air distribution mode to Distribution to Feet.

In the ON state, if the Distribution to Feet Mode button is pressed, the corresponding indicator comes on and it becomes the Distribution to Feet Mode, the operation of the Distribution to Feet Mode button is

invalid at this time, and it will change to other modes if another mode button is pressed.

Distribution to Feet and Defrost Mode button

Adjust the air distribution mode to Distribution to Feet and Defrost.

In the ON state, if the Distribution to Feet and Defrost Mode button is pressed, the corresponding indicator comes on and it becomes the Distribution to Feet and Defrost Mode, the operation of the Distribution to Feet and Defrost Mode button is invalid at this time, and it will change to other modes if another mode button is pressed.

Air volume adjusting knob

Adjust the blower air volume.

The air volume is divided into 8 levels. Rotate a grid to the right, the A/C air volume will increase by one level; rotate a grid to the left, the air volume will decrease by one level. When the air volume is adjusted to the 8th level, the knob reaches the far right and can no longer be rotated to the right; when the air volume is adjusted to the 0 level, the knob reaches the far left and can no longer be rotated to the left.

A/C button

Switch on and off the compressor.

With the blower in ON state, press the A/C button, the corresponding indicator lamp illuminates and the compressor is turned on (engine is started); press the A/C button again, the A/C indicator lamp goes out and the compressor is turned off.

Front Defrost Button

Adjust the air distribution mode to Front Defrost.

With the blower in the on state, press the front defrost button, the corresponding indicator lamp illuminates, the air volume remains in the current level, air flows into the vehicle through the external circulation, A/C is turned on and the air distribution mode is defrost. At this time, the internal/external circulation mode, air volume and A/C are adjustable.

In the Front Defrost state, if the Front Defrost button or other mode buttons are pressed a second time, the front defrost function is off, the front defrost indicator goes off and the system returns to the previous state before the Front Defrost.

Rear Defrost Button

Switch on the rear defrost state. Rear defrost can be activated only when the ignition switch is turned to On position. The operation of the Rear Defrost button will not change other air conditioning states regardless of power on or off, meanwhile the corresponding indicator varies according to the rear defrost state (vehicle is started).

For vehicles equipped with the heated exterior rearview mirror, press the Rear Defrost Button to activate the heated exterior rearview mirror, to help clear the fog or frost on the surface of rearview mirror.

Note: The rear defrost will stop after operating for 15 minutes, and its indicator goes off.

Internal/External Circulation Button

Switch between the internal and external circulation with the button, when the internal circulation indicator lamp illuminates, it indicates that it is in internal circulation, when the indicator lamp goes out, it indicates that it is in external circulation.

When it is in the defrost mode, switch to external circulation forcibly, then you can switch back to internal circulation manually.

It is defaulted to memorize the state before the shutdown at the power-on.

Rear A/C control button

When the ignition switch is in ON position, the REAR button can make adjustments. The REAR button indicator lamp illuminates, which indicates that the rear A/C is in the operating state, press the REAR button at this time, the indicator lamp goes out, and the rear A/C is turned off; the REAR button indicator lamp off indicates that the rear A/C is in off state, press the REAR button at this time, the indicator lamp illuminates, and the rear A/C is turned on.

Automatic A/C rear control panel

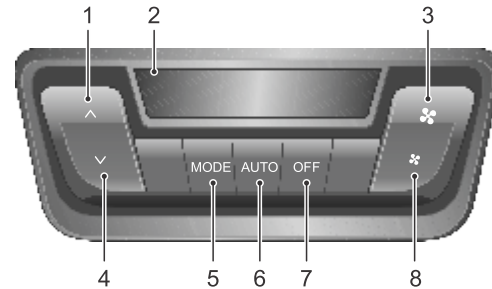

- 1 Rear A/C temperature + selection button
- 2 Rear A/C display
- 3 Rear A/C air volume + adjusting button
- 4 Rear A/C temperature - selection button
- 5 Rear A/C mode button
- 6 Rear A/C AUTO button
- 7 Rear A/C panel OFF button
- 8 Rear A/C air volume - adjusting button

Rear A/C temperature selection button

There are 2 rear A/C temperature selection button, namely, temperature+ button and temperature- button, there are totally 8 temperature levels.

BEFORE YOU DRIVE

In the OFF state, the temperature + and - buttons are invalid, in other states, the temperature + and - buttons can adjust the temperature, but do not change other states of the controller.

Press the temperature + button once, the set temperature will increase by 1 level, and it will change continuously after long pressing the button for 1 seconds.

Press the temperature - button once, the set temperature will decrease by 1 level, and it will change continuously after long pressing the button for 1 seconds.

Rear A/C air volume adjusting buttons

Adjust the air volume, there are 6 levels for each button.

The air volume of A/C increases by one level once the air volume + button is pressed; the air volume decreases by one level once the air volume - button is pressed.

When long pressing the air volume + button for more than 1 second, the air volume will continuously increase to the 6th level by changing 1 level every 0.5 second.

When long pressing the air volume - button for more than 1 second, the air volume will continuously decrease to the 1st level by changing 1 level every 0.5 second.

Press the air volume button in the OFF state, the controller will exit the OFF state and return to the state before OFF, and the air volume level before OFF in memory will be recalled.

In the OFF state, by pressing the air volume + or - button, the controller will enter the ON state, and the air volume output will gradually increase from the 1st level to the one before OFF in memory, and other functions maintain the state before OFF.

Rear A/C mode button

Change the air distribution state of the damper, press the mode button to switch to the following air distribution state of the damper in sequence: Distribution to Face mode, Distribution to Face and Feet mode, Distribution to Feet mode.

Rear A/C AUTO button

After pressing the AUTO button, the A/C enters the AUTO control mode, the AUTO icon is displayed on the LCD.

In the AUTO state, press either of the mode, air volume button, the corresponding function will exit the AUTO mode, and other functions remains unchanged, the AUTO icon on the LCD will go out.

Rear A/C panel OFF button

Used for power on/off, in the OFF state, press the mode button again, and the heating and cooling buttons will not respond.

Press the OFF button to switch to the OFF state, the LCD output is closed, the air volume is in 0 level, and the mode motor, the heating and cooling motor stops after running to the position set before OFF.

In the OFF state, operate the air volume button or AUTO button to enter the On state, the air volume, mode, AUTO, set temperature will resume to the state before OFF.

Electronic A/C rear control panel

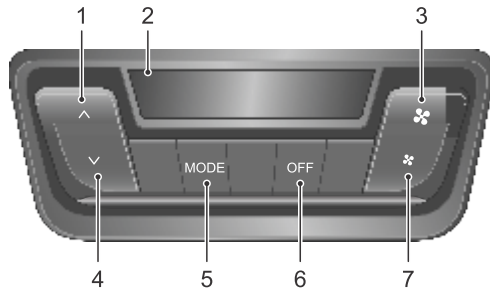

- 1 Rear A/C temperature + selection button
- 2 Rear A/C display
- 3 Rear A/C air volume + adjusting button
- 4 Rear A/C temperature - selection button
- 5 Rear A/C mode button
- 6 Rear A/C panel OFF button
- 7 Rear A/C air volume - adjusting button

Note: Please refer to “Automatic A/C Rear Control Panel” in this section for the operating and control logic of the functions contained in this control panel.

Recommendation for A/C Operation

- If the vehicle is parked in a place that is exposed to the direct sunlight, open the windows before operation.
- If the fogged windows need to be cleaned in a rain day, reduce the moisture in the vehicle by operating the air conditioning. This is very effective in rainy season and a season with heavy moisture.
- If the vehicle is driving in the city, the stop-and-go may cause the insufficient cooling.

Note: If the air conditioning will not be in use for more than one month, run the engine at idle speed and turn on the system for more than 10 minutes (once every month, including in winter). This aims to maintain the proper lubrication of the compressor and the seals, so as to extend the service life of the system.

Note: Condensation may be formed on the evaporator when the A/C is operating. So you may find a small pool of water under the vehicle after the vehicle is stopped.

Rearview Mirrors

In order to extend the view range, exterior rearview mirrors are convex-shape, which makes objects look smaller and farther than the actual.

Caution

Be sure to check and ensure that all rearview mirrors are clean and bright, and adjusted well before driving; clean and adjust them if necessary.

Exterior Rearview Mirrors

Power rearview mirrors

Press the switch L (left) or R (right) to select the rearview mirror to be adjusted. Move the rearview mirror switch towards front/rear/left/right to adjust the rearview mirror lens to tilt towards up/down/left/right to the position required. Move the switch to the middle position.

Switches not equipped with power folding function

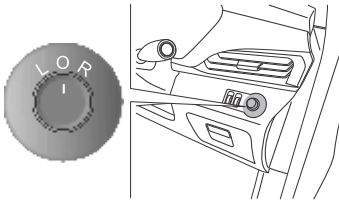

Switches equipped with power folding function

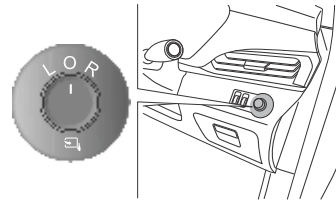

Folding rearview mirrors

Manual folding of rearview mirrors

In order to ensure the safety of pedestrians, exterior mirrors will rotate from their normal mounting positions towards both sides if impacted with a strong force. Reset the rearview mirrors by applying little pressure onto the mirror frames.

Power folding of rearview mirrors

For vehicles equipped with power folding rearview mirrors, it is allowed to fold/unfold exterior mirrors manually/automatically.

- Manual power folding/unfolding of rearview mirrors

When rearview mirrors are folded, turn the ignition switch to ACC/ON position and move the switch to any of L/O/R position, the rearview mirrors will be unfolded.

When rearview mirrors are unfolded, turn the ignition switch to ACC/ON position and move the switch  to position, the rearview mirrors will be folded.

- Automatic power folding/unfolding of rearview mirrors

When rearview mirrors are folded and the ignition switch is placed in OFF position, the key to unlock, then rearview mirrors will be unfolded automatically. Or, rearview mirrors will be automatically unfolded as long as there is a legitimate remote key with PEPS existing within the range of 1 meter around the vehicle, press the micro switch on the driver door handle.

When rearview mirrors are unfolded and the ignition switch is placed in OFF position, the key to lock, then rearview mirrors will be folded automatically. Besides, when doors are unlocked but not opened, after 30s, doors will be automatically locked again and rearview mirrors will resume to folding state.

Memory position function of front power driver seat

The position of rearview mirrors can be stored in the memory position function of the power driver seat. Please refer to "Seats" in this Section for details.

Heated rearview mirrors

For vehicles equipped with the heated exterior rearview mirror, press the Rear Defrost Button  on the A/C control panel to heat the exterior rearview mirror.

Exterior rearview mirrors automatically tilt during reversing

When the driver shifts the lever to the R gear position, the exterior rearview mirrors on both sides will tilt automatically, letting the driver see the curbs or rear wheels and facilitating the reverse operation. When the driver moves the shift lever out of the R gear position to finish the reversing, the exterior rearview mirrors will return to their original positions automatically.

The touch buttons on the large-size screen of entertainment system control the enabling and disabling of the automatic tilt function of exterior rearview mirrors during reversing. Please refer to the operating instructions accompanied with the entertainment system head unit for details.

Exterior rearview mirrors automatically tilt during reversing function setting

Place the ignition switch in "ON" position, apply the brake pedal to stop the vehicle. Shift the lever to R gear position, adjust to tilt the left and right rearview mirrors respectively to the desired position. Move the shift lever out of the R gear position and the rearview mirrors will return to their original positions automatically.

Interior rearview mirror

Adjust the rearview mirror to obtain the required rear view.

Manual adjustment of interior rearview mirror

Operate the adjusting lever on the bottom of rearview mirror to reduce reflected glare during night driving.

Power adjustment of Interior rearview mirror

For vehicles equipped with power adjusting interior rearview mirror, press the AUTO button (2) on the rearview mirror bottom. Then the green LED lamp (1) will illuminate and rear light sensor will start operating to reduce reflected glare during night driving. Press the button (2) again. Then the green LED lamp will go off and rear light sensor will stop operating.

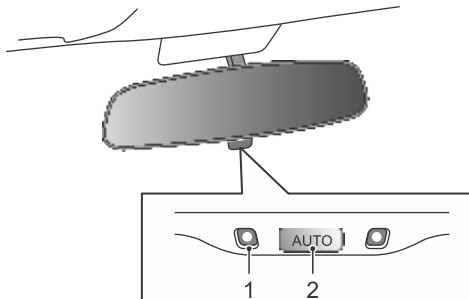

Interior Devices

Ceiling reading lamps

Front ceiling reading lamp



Turn on the reading lamp

Press  to turn on the internal reading lamp.

Turn on door control mode

Press , the internal reading lamps will automatically illuminate after any one door is opened, and go out approximately 30 seconds after the door is closed.





With the doors closed, place the switch in  position, press the black cover, and turn on the internal reading lamp.

Turn off the reading lamp

Press , to turn off the internal reading lamp.

With the doors closed, place the switch in  position, press the black cover and turn on the internal reading lamp.

Rear ceiling reading lamp**On/off switch**

When the front ceiling reading lamp is in the door control mode, and all doors are closed, press the / , turn on the rear ceiling reading lamp, and press the /  again, turn off the rear ceiling reading lamp. When any door is opened, rear ceiling reading lamps will go on. About 30s after the door is closed, rear ceiling reading lamps will go off automatically.

Note: 15 min after any door is opened, rear ceiling reading lamps will go off automatically to prevent battery drain.

USB port

The USB ports are located in the storage box of floor console, at the rear bottom side of central armrest, and on the left rear side armrest.

Caution

Please do not use the USB port for a long time when the ignition switch is placed in ACC position, which may lead to battery drain.

The USB port in the storage box of floor console

The USB port in the storage box of floor console can be used for charging and multimedia files playback, please refer to "MP3+Radio" and "MP5+Radio" in this section for the method of multimedia file playback via USB and the file requirements.

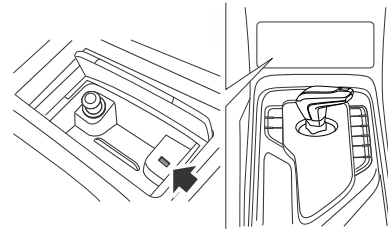

BEFORE YOU DRIVE

The USB port at the rear bottom side of central armrest

The USB port at the rear bottom side of central armrest can be used for charging or multimedia file playback, (this function depends on the actual configuration of your vehicle), please refer to "MP5+Radio" in this section for the method of multimedia file playback via USB and the file requirements.

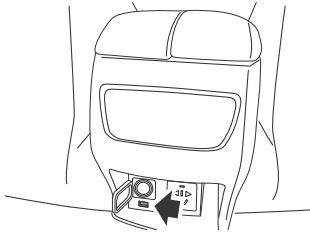

The USB port on the left rear side armrest

The USB port on the left rear side armrest can be used for charging.

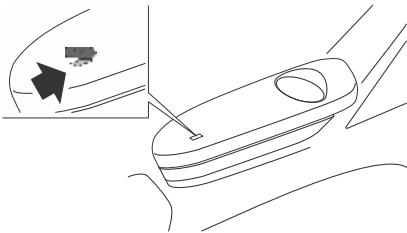

12V power outlet

The power outlets are located in the storage box of floor console, at the rear bottom side of central armrest between the driver and front passenger, on the right rear side armrest, at the left side of luggage compartment, they are mainly used for providing power supply connection for external electric devices.

Note: The type and location of 12V power outlet shall be subject to the actual configuration of the vehicle you purchased.

Caution

Please avoid using the power outlet for a long time when the ignition switch is placed in ACC position, which will lead to battery drain.

Note: The power outlet can provide power supply for electric devices of which power is no more than 120W.

BEFORE YOU DRIVE

Storage box of floor console

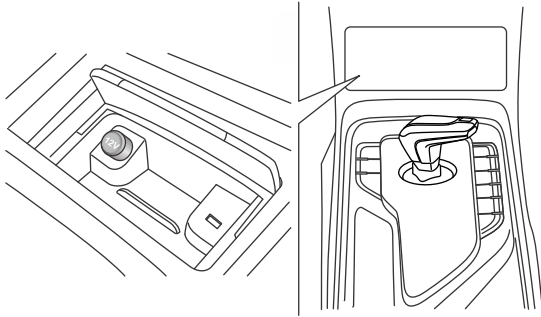

Right rear side armrest

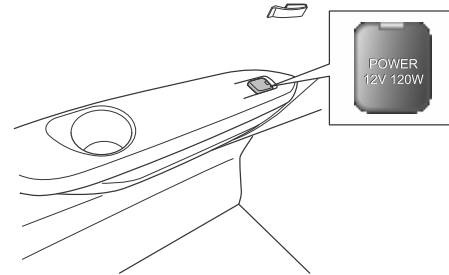

Rear bottom side of central armrest

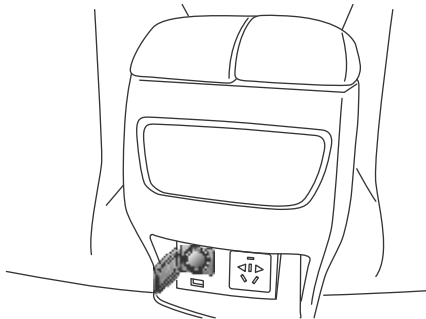

Left side of luggage compartment

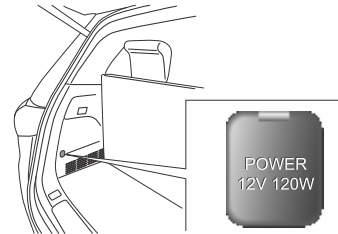

Mobile phone wireless charging system

If your vehicle is equipped with a mobile phone wireless charging system, the system can achieve wireless charging of mobile phones through electromagnetic induction, without the need for a wire connection.

Note: *The mobile phone wireless charging system is not applicable for all mobile phones, only for “Qi” certified phones.*

Operation of mobile phone wireless charging

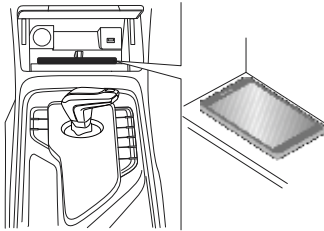

Open the storage box and place the phone as shown above (with the phone screen facing forward). When the phone is charging, a buzzer sounds to alert the driver. When the vehicle is turned off, if the vehicle recognizes that the phone is still charging, the buzzer will alert the driver.

Note: *The mobile phone wireless charging module may stop working when the low frequency antenna of the keyless start system is searching for keys.*

Mobile phone wireless charging failure

If a failure occurs during charging, it may be caused by the following:

- The vehicle battery voltage is too low.
- A metal foreign object exists in the charging area. Please take the phone away to check if there is any foreign object. If so, remove the foreign object and place the phone in the charging area again.
- The temperature is too high.
- There is an internal failure in the mobile phone wireless charging system.
- The mobile phone is malfunctioning.

Caution

When the driver leaves the vehicle, please do not place the mobile phone in the vehicle for charging, so as to avoid potential safety hazards. During charging, do not leave metal foreign objects such as coins, keys, chip cards, etc. on the charging area, which may cause the metal to be heated, resulting in failure to charge and safety accidents. Only one phone can be charged at a time. Do not spill water on the charging area to avoid water entering the wireless charger through the gaps in the rubber pad and causing the charger malfunction. Charging of the phone may stop when the temperature is too high, and will continue to charge when the temperature drops.

BEFORE YOU DRIVE

Cup holder

Cup holder on the floor console

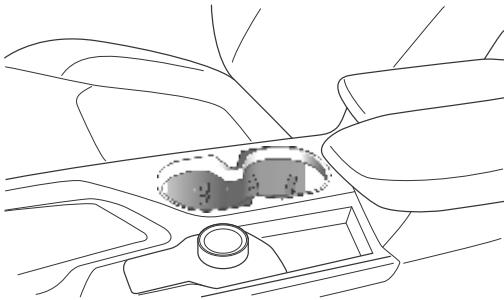

Cup holder on the armrest of second row seats

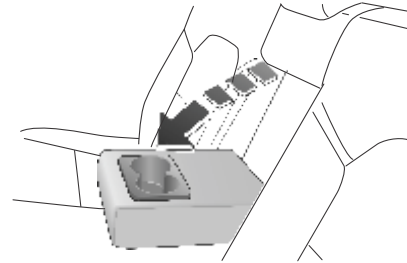

Cup holder at both sides of third row seats

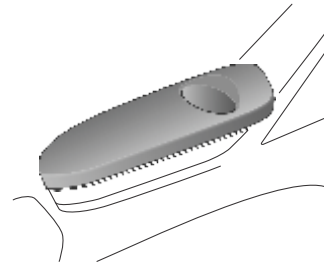

BEFORE YOU DRIVE

Storage box

Storage box at driver side

The storage box at driver side is located below the front of the floor console at driver side. It can be opened by releasing the storage box upper buckle.

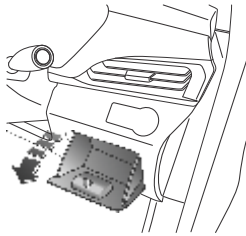

Storage box of floor console

It is located in the front of the floor console, press the storage box to open, and press it again to close.

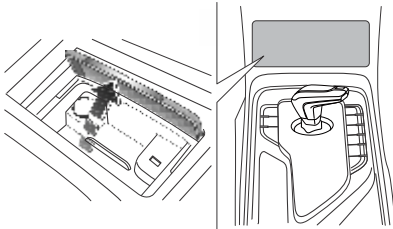

Storage box under the front armrest

Type I

Lift the armrest to open the storage box.

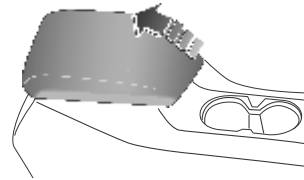

Type II

When the unlock button is pressed, the cover will pop up and open automatically.

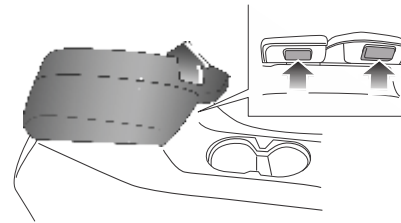

Glove box



Do not place a sharp, heavy or hazardous object in the glove box at front passenger side.

In case of an accident or sudden braking, the glove box may cause personal injury if not closed. Therefore, please close the glove box during driving.

Press the button on the upper side of glove box to open the glove box (if your vehicle is equipped with a glove box lock, you need to insert the key and turn it counterclockwise to unlock). Push it hard to close it.

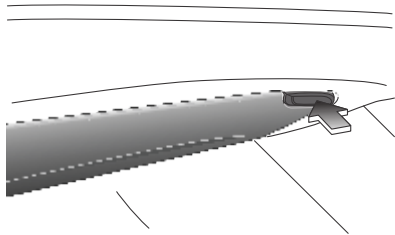

Sun visor and vanity mirror

Pull both sun visors upwards or downwards to block the sunshine through windshield. Besides, sun visors can be rotated towards side windows.

Turn a sun visor downwards and open the vanity mirror cover. Then you can use the vanity mirror.

Driver's vanity mirror shall be used only when the vehicle stops.

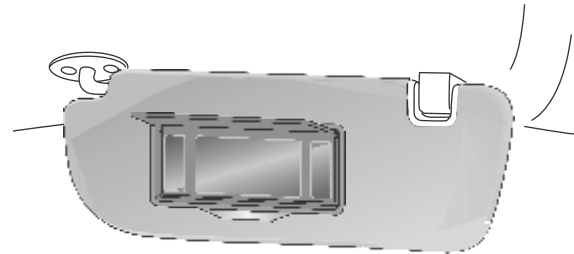

BEFORE YOU DRIVE

Glasses box

The glasses box is located between the A pillar and B pillar at driver side.
A sunglasses can be put in the box.

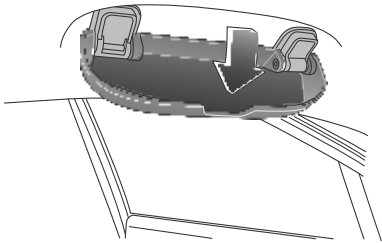

Vehicle tools

The vehicle tools are placed at the bottom of the luggage compartment (for vehicles with three rows of seats) or behind the second row of seats (for vehicles with two rows of seats).

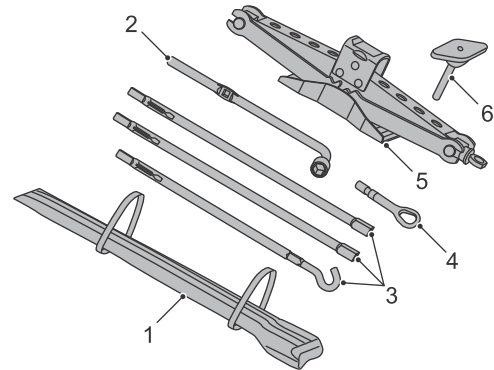

- 1 Vehicle toolkit
- 2 Wheel nut wrench
- 3 Auxiliary rotating extension rod of jack
- 4 Rear towing eye
- 5 Jack
- 6 Jack fixing screw

Caution

MP5+Radio

Precautions before Use

For the instructions of MP5+Radio in the vehicles, please refer to the operating instructions accompanied with the entertainment head unit.

Please read carefully and fully understand the operating instructions accompanied with the entertainment head unit before you use this product.



Please do not install or repair your product without authorization.

If the product is installed or repaired by a person who does not receive the training on electronic equipments and auto parts, a dangerous situation may be posed.

According to the relevant national regulations, watching videos and related operations are prohibited during driving for the personal safety of yourself and others. Please do not watch the screen and make related operations when driving a vehicle.

Never expose the product to any liquid, otherwise short circuit or damage may be caused.

The rear view camera function of the system just serves as a driving aid, please pay attention to the actual situation.

- The product shall be kept away from moisture.
- Be sure to drive safely.
- Make sure to follow the rules of safe driving and existing traffic regulations.
- Do not do that if the operation of this product (and the rear view camera function) may have your attention diverted when you are safely driving.
- If you have to operate by viewing the screen, please park the vehicle at a safe place and apply the parking brake.
- Do not set the volume of the product too high, or you will not hear the traffic conditions and emergency rescue signals outside.
- For the sake of safety, some features, such as video playback, will be disabled when driving.
- The system can detect the running speed of the vehicle. When the speed exceeds a certain value, the system will prevent you from watching a video when you drive. If you want to watch a video, please park the vehicle in a safe place and apply the parking brake.
- To prevent battery drain, please make sure to start the vehicle when the system is used.

Entertainment System Control Switch

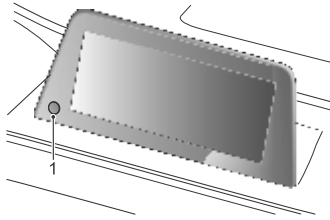

I HOME Button

Main interface mode, long press for 3 seconds to turn off and long press for 10 seconds to reboot.

Introduction and Operation of Main Interface Function



I Displaying device connection status

The connection status of Bluetooth and USB is displayed. When they

are connected, the corresponding icons will be highlighted. If they are not connected, the relevant icons will not be displayed.

2 Time Display

The current system time is displayed.

3 Volume Button

The current volume information is displayed. Touch this button to show the volume bar. Slide the volume bar can directly adjust the volume.

4 Vehicle State Mode Icon

Touch the vehicle state mode icon to enter the vehicle state interface to operate.

5 Contact Mode Icon

Touch the contact mode icon to enter the contact mode to operate.

6 Main Menu Mode Icon

Touch the menu icon to operate Carplay, A/C, Mirror link and App, settings.

7 Radio Mode Icon

Touch the radio mode icon to enter the ratio interface to operate.

8 Multimedia Mode Icon

Touch the multimedia mode icon to enter the multimedia interface to operate.

Common Troubleshooting

Symptoms	Possible Causes	Solution
Screen Too Dark	Improper Brightness Setting	Enter the screen setting to adjust the brightness of screen
	Vehicle Headlamp Normally ON	Vehicle Headlamp OFF
Not Power On	Appliance Power Supply or Vehicle Fuse Blown	Please ask Service Dealer to replace it with the fuse of correct type.
No Sound Output	Unit Mute	Short press the mute button on the steering wheel or short press the mute icon on the top.
	When playing a video, you have returned the directory, homepage or entered the setting interface.	The video is in pause state at the moment, then enter the video interface to continue to play.
Bluetooth music mode mutes	It is switched to Bluetooth music but not playing.	Play Bluetooth music from your mobile phone or short press the play button on Bluetooth music.
Low Volume	The volume is adjusted to a low level.	Operate Volume + button to adjust volume.
	The channel balance position is far away from the center.	Enter the setting to adjust the channel balance position to the center.
The radio cannot find valid stations.	The radio antenna is not properly connected.	Connect the radio antenna properly.
A USB flash disk is inserted but its failed to enter USB mode.	The USB flash disk has poor quality.	Make sure that the USB flash disk is original and quality-assured.
	There is no any audio, video or image resource in the USB flash Disk	Check the USB flash disk for any available media content.

BEFORE YOU DRIVE

Symptoms	Possible Causes	Solution
Slow response after inserting the USB flash disk.	The USB flash disk has poor quality.	Make sure that the USB flash disk is original and quality-assured.
	The capacity of USB flash disk exceeds the limit of 32G.	Please use the USB flash disk with a capacity within 32G.
	The hierarchical arrangement of folders is too complex and there are too many folders.	Clean up the USB flash disk to guarantee a clear hierarchical arrangement of folders in the USB flash disk.
	There are large capacity files in the USB flash disk.	Clean up the USB flash disk and remove the large capacity non-media files.
A reminder is given that the audio or video file is not supported, it gets stuck or mosaic or no playing, etc happens.	The audio or video file is damaged.	Ensure that the audio or video can be played normally on the home computer.
	The video resolution exceeds 1920*1080 and the bitstream is over 50M/S.	Be sure that the playing file is within the set range.
	Non-video DAT File	DAT is a special format, which is classified into video format and data format. The DAT file of data format is not supported.

Caution

If the failure still exists, take your vehicle to our service dealer for service. Don't disassemble the on-board entertainment system for repair by yourself without authorization.

STARTING AND DRIVING

- 108 Before Starting and Driving
- 108 Ignition Switch
- 110 Keyless Start System
- 112 Engine Immobilizer System
- 113 Start/Stop the Engine
- 115 Intelligent Start/Stop System
- 118 Driving
- 120 Catalytic converter
- 124 Fuel
- 127 Urea
- 128 8AT Automatic Transmission
- 134 Electric Power Steering Device
- 135 Four Wheel Drive System (4WD)
- 138 Electronic Differential Lock
- 139 Brake System
- 148 Constant Speed Cruise Control System
- 151 Parking Assist System
- 158 Driver Assist System
- 177 Tyres
- 178 Loading

Before Starting and Driving

- Conduct daily/weekly maintenance checks on the vehicle in accordance with the provisions in Maintenance- Owner Checks.
- Ensure seats are in correct positions through check.
- Ensure all rearview mirrors are adjusted to correct positions through check.
- Ensure all lighting, signal systems and warning indicators operate normally.
- Ensure all passengers have fastened their seat belts correctly through check.

Move the ignition switch in "ON" position, and ensure all warning lamps and gauges operate normally through check. Please refer to "Warning Lamps and Indicator Lamps" in the Before You Drive section.

Caution

Before reading this chapter, please make sure you have read the Before You Drive section in this manual and you have been familiar with your vehicle and on-board equipment.

Ignition Switch

Keyless Start

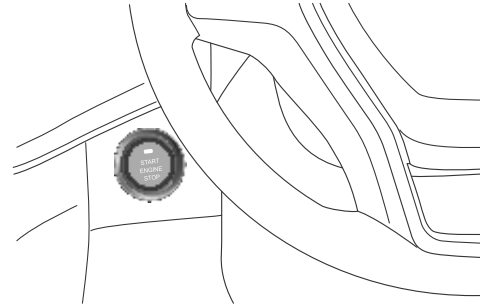

Note: The vehicle is equipped with electronic hands-free key ignition switch, that is, the start-stop switch for button-type start. To start the vehicle, the PEPS key must be in the vehicle. For an AT model, if you want to move the shift lever out of P, you must depress the brake pedal with the ignition switch in ON position.

ACC - red lamp

- Start Failure
In case of engine start failure, the ignition switch will switch to ACC.
- Abnormal Parking

STARTING AND DRIVING

When the engine is running and the shift lever is not in P gear, press this button and ignition switch will switch to ACC.

- Emergency Flameout

When the vehicle speed is higher than 5km/h during driving, press the ignition switch for 3 times continuously or long press it for 3s, the ignition switch will switch to ACC.

Note: Red lamp flashing 3 times indicates that a legal physical key/Bluetooth key is not detected in the vehicle.

ON - Green lamp

When the engine shuts down and the starting conditions are not met, press this switch once, the ignition switch will switch to ON; after the engine is normally started, the ignition switch will switch to ON; when in ON state, all instruments, control devices and circuits can operate.

Nota: If the ignition switch is still placed in ACC or ON position after engine shutdown, the battery power will be drained. The vehicle may be unable to start if the battery power drain time is too long.

START - Green lamp

This position is used for starting the vehicle. When the engine shuts down, there is an effective remote key in the vehicle and the starting conditions are met, press and release this button, and then engine will be started.

Starting conditions:

- Place the shift lever in P or N position.
- Depress the brake pedal and hold.

OFF

This position shuts down the engine. When the shift lever is placed in P position, press this switch and the ignition switch will switch to OFF.

Caution

When the vehicle is close to strong radio antenna signals, there may be an interference effect on the remote door lock system and the start-stop switch will not work.

Keyless Start System

Keyless Unlocking

When all doors are locked, enter the sensing area with a remote key and press the micro switch, the central lock will unlock automatically. After unlocking, direction indicator lamps will flash twice. If you do not conduct any of the following operations within 30s after that, the central lock will automatically lock again:

- Open any door
- Shift the power supply position to a non-OFF position
- Operate the central lock to unlock/lock

Note: It is feasible to unlock doors with the central unlocking button on the remote key. Press the central unlocking button once, and the central lock will unlock automatically.

Keyless Locking

When the driver's door or front passenger's door is unlocked, enter the sensing area with a remote key, and then press the micro switch on the door handle. The direction indicator lamps will flash once, meanwhile the alarm horn will ring once for a short time (as appropriate). Then all doors will be locked, meanwhile the vehicle enters the fortification state. In any of the following cases, the doors will not be locked after the micro switch is pressed:

- The power supply switch is placed in non-OFF position
- The remote key is left in the vehicle
- The remote key is not in the sensing range
- The remote key battery is low
- The driver's door is open

Note: It is feasible to lock doors with the central locking button on the remote key. Press the central locking button once, and the central lock will lock automatically.

Keyless Start

When the remote key is left in the vehicle and the starting conditions are met, press the start-stop switch once at this time, and then the engine will be started.

Starting conditions:

- Automatic Transmission

Place the shift lever in P or N position.

Depress the brake pedal and hold.

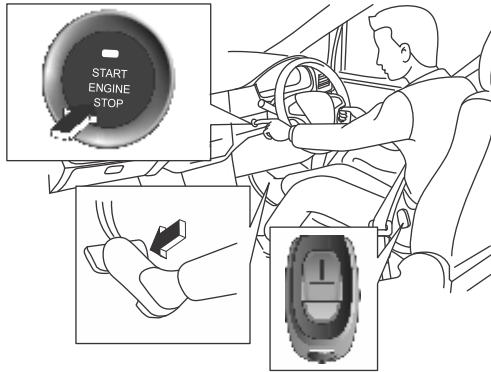

Note: *If the starting conditions are not met, every time you press the start-stop switch, the power supply positions will be switched among OFF, ACC and ON in a cycle. If*

the remote key is not in the vehicle, after depressing the brake pedal, the indicator lamp will not illuminate, and the power supply position switching or ignition action will not be performed after the start-stop switch is pressed.

Backup Starting

When the remote control battery is low, the keyless entry function will fail, but you still can start the engine. Open a door with the mechanical key and enter the vehicle. At this time, the system may be in IMMO state and the alarm may be triggered, which is a normal situation.

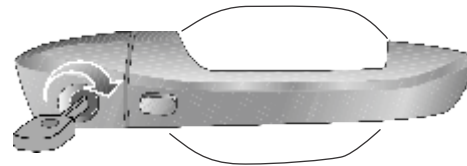

On the premise of meeting starting conditions, lay the key flat in the position with an identification in the storage box which is in front of the central armrest and press the start-stop button. Then the engine can be started.

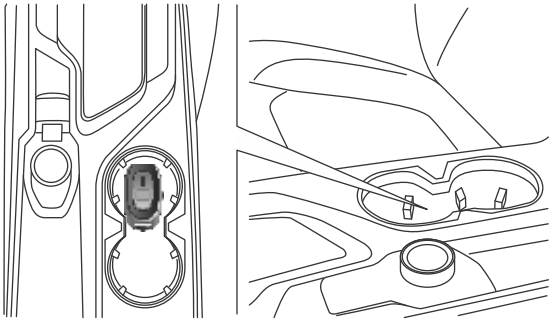

Emergency Flameout

If you need to shut down the vehicle immediately during driving due to an emergency, there are two methods to shut down the engine:

- 1 Keep pressing the start-stop switch within 3s.
- 2 Press the start-stop switch for continuous 3 times.

Engine Immobilizer System

Keys

The keys have been coded electronically for your vehicle. The coded keys can be used for the corresponding vehicle only. Only the keys attached with the vehicle can start your engine.

The engine can not be started only when the remote key is in the vehicle.

When the immobilizer system is effective, any illegal behavior to start the engine will be prohibited.

Enable/disable

When the start-stop switch is placed in ON position, if the authentication succeeds, the IMMO warning lamp (yellow) on the instrument cluster will keep off for a long time. If the IMMO warning lamp (yellow) flashes, it is shown that the immobilizer system goes wrong and the engine cannot be started. Contact a service provider authorized by the Company for overhaul immediately. If the remote key is not in the vehicle or there is certain interference, the information center on the combination cluster will display the prompt "Key not in the vehicle". If the battery of remote key shall be replaced, the information center on the combination cluster will display the prompt "Please replace the battery of remote key". Please replace the battery of remote key as soon as possible.

Note: *The remote key contains a microchip which guarantees the fault-free data exchange between the key*

and the vehicle. Do not shield the key with a metal object (such as another key). Prevent it from severe impact. The quantity of keys hung on the key ring shall not exceed 1.

Start/Stop the Engine

Starting



CO is a harmful gas and may cause coma, even death. Avoid inhaling vehicle exhaust because it contains colorless and odorless CO. Do not start the engine or keep the engine running in an airtight and unventilated place. If you find there is exhaust in the vehicle, find out the cause as soon as possible and correct. If you have to operate in this kind of environment, please open all windows completely.

- Automatic Transmission
Place the shift lever in P or N position.
Depress the brake pedal and hold.

Place the ignition switch in ON position, and wait for the “glow plug indicator lamp (yellow)” on the instrument cluster to go off. Press the start-stop switch to START position to start the engine. After the engine begins running, release the start-stop switch immediately, and the ignition switch will automatically return to ON position. Please refer to “Ignition Switch” and “Keyless Start System” in this section.

Note: During starting, do not keep the starter running for 10s above. If the engine is not started, wait for at least 30s after turning off the ignition switch and try again. As the ambient temperature declines, the engine starting time may increase correspondingly. Therefore, please turn off all unneeded electrical appliance

STARTING AND DRIVING

temporarily during starting. At a weather with the temperature below -25°C, please park the vehicle in the garage.

Caution

Avoid high-speed and full-throttle running before the engine reaches the operating temperature.

Caution

For vehicles equipped with diesel engine, keep the engine idling for 10s before shutdown, in order to ensure the turbo charger bearing is fully lubricated during the deceleration.

Warm-up

When the engine temperature is relatively low, there will be a poor effect if the engine is warmed up with the vehicle in stationary state. It is recommended to drive the vehicle as soon as possible after the engine is started.

Self-protection mode

In case of an engine fault which may affect driving performance during driving, the engine system will enter the "self-protection mode". In this case, the "engine MIL (yellow)" on the information center display screen will start flashing or stay on. Please contact Service Dealer for service immediately.

Shutdown

Turn the ignition switch from ON to OFF position to shut down the engine.

Pull up the EPB switch.

STARTING AND DRIVING

Intelligent Start/Stop System

Note: It is suitable for vehicles installed with intelligent start/stop system.

Basic conditions of usage

The intelligent start/stop system can help to save fuel consumption and reduce CO₂ emission. When the intelligent start/stop system is in use, if the vehicle is stopped at a red light, the engine will be shut down automatically when the vehicle is stationary. During the engine stop period, the ignition switch remains On. When necessary, the engine will be automatically started again. When the ignition switch is turned on, the intelligent start/stop system will be activated automatically.

Basic conditions of usage for the intelligent start/stop system:

Sr. No.	Problem	Limits
1	Start Stop EN/Abled Switch	γ
2	Engine Hood is Closed	γ
3	Driver Door is Closed	γ
4	Seatbelt is attached	γ
5	Vehicle Speed > threshold after Key start	10 Km/hr
6	Shift Lever in D position	γ
7	Slope <threshold	±4 deg
8	Time > threshold after engine start up	10s

Sr. No.	Problem	Limits
9	Brake Pedal Position > threshold	5%
10	SOC > threshold	65%
11	SOF > threshold	7.2v
12	Threshold Battery Temp < Battery	00c -600c
13	Brake Boost Vacuum < threshold	50 Kpa
14	Engine Coolant Temperature	105degC>T>45degC
15	Release Brake Pedal < threshold	5% min
16	Press accelerate pedal > threshold (auto-hold working)	10%
17	Regeneration of Catalyst (During regeneration cycle the engine cannot be interrupted its function cycle)	N

Note: The engine has been shut down before the vehicle is about to enter in stationary state. However, the full functions of brake booster system and power steering system still can be guaranteed.

Caution

When driving across water, the driver should always keep the intelligent start/stop system inactivated.

Shutdown and startup of engine

Vehicles with automatic transmission

Please conduct a full braking to the vehicle; after the vehicle is stationary, keep depressing the brake pedal to shut down the engine (engine stop phase). Meanwhile, the "Intelligent Start/Stop System Indicator lamp (green)"  on the information center of the instrument cluster illuminates.

Once the brake pedal is released, the engine will be started again. If the parking assist function is activated, the engine will re-started only when the accelerator pedal is depressed. The indicator lamp goes out.

Additional information about the vehicle with automatic transmission

- Only when the shift lever is in D position will engine be shut down.
- If the shift lever is moved out of the D position during the engine stop phase, the engine will be started again.
- Regardless of whether the engine is shut down or not, you can reduce or increase the braking force at your own. For stop-and-go driving or cornering, if the brake is slightly depressed, the engine will not stop while the vehicle is stationary. Once the brake pedal is depressed hard, the engine will be shut down immediately.

Caution

When the engine is shut down, please depress the brake pedal to avoid vehicle slip. If the engine intelligent start/stop system switch  on the floor console is pressed during the engine stop phase, the engine will get started automatically. If the driver door is opened or the driver seat belt is unfastened, the engine will not get started automatically; to start the engine, please move the shift lever to P or N position, and then start the engine with the start button or key.

Instructions

Normal intelligent start/stop action may be interrupted due to different system conditions.

The engine is not shut down

Before and during the engine stop, the system will check whether the particular conditions have been met. Under any of the following circumstances, the engine will not be shut down:

- The engine has not yet reached the minimum temperature at which the start/stop system can operate.
- The windshield is being defrosted.
- The battery charging status is too low.
- After the replacement or reconnection of the battery, the vehicle is not locked for more than 4h.
- The shift lever is not in the D position.
- The slope is very steep.
- The altitude is very high.
- The braking vacuum is insufficient.
- The engine MIL/ESP MIL illuminate.

When the start/stop conditions are not met, the "Intelligent Start/Stop

System Indicator Lamp (white)"  illuminates.

The engine gets started again automatically

During the engine stop phase, under any of the following circumstances, the normal start/stop operation will be interrupted.

The engine gets started again without the action of the driver.

- The vehicle rolls like on a slope.
- The windshield is being defrosted.
- The battery charging status is too low.
- High current consumption.
- The braking vacuum is reduced.

If the conditions for intelligent start/stop operation are met again, the engine may be shut down again.

Caution

- On vehicles equipped with automatic transmission, if you shift to D gear after moving into reverse gear, then you must drive the vehicle at a speed of 10 km/h first to facilitate the system's shutdown of the engine again.
- If you do not want to use the system, you can turn it off manually. Press the engine intelligent start/stop system switch (A) on the floor console, the start/stop system will be turned off; and then the dialog box that "Start/Stop System Off" will displayed in the information center of the instrument cluster.
- When the "Intelligent Start/Stop System Indicator Lamp (yellow)"  illuminates, it indicates that the system has a malfunction! The function is disabled.
- The intelligent start/stop system has a malfunction. Please contact our Service Dealer for troubleshooting.

Driving

"Running-in" of new vehicle

The vehicle does not need intentional "running-in". In order to improve the long-term operating performance of the vehicle, we strongly recommend that you abide by the following points:

Within the first 3,000km:

- Avoid driving fast and frequent shifting.
- Do not depress the accelerator pedal all the way down at any gear.
- Do not keep the engine run slowly with difficulty at any gear.
- Please try to avoid using the emergency brake excessively.

After the mileage reaches 3,000km, you can gradually increase the vehicle speed to the maximum admissible speed.



Avoid using high engine speed to protect the engine, reduce fuel consumption, lower engine noise level and protect the environment.

Driving



During driving, do not place any portable container filled with fuel in the vehicle. Otherwise a fire may occur due to leakage.

When driving on a risky road covered with water, snow, ice, mud, sand, etc., please:

- Slow down drive with care and reserve longer brake distance.
- Avoid any sudden operation during braking, steering or acceleration.
- Apply sand or other anti-skid material under the driving wheels or install tyre chains on them to provide the traction needed when the vehicle gets stuck in ice, snow or mud.

Skid

If your vehicle skids on a wet road, you cannot control the vehicle due to the decrease of friction force between the road and tyres. Different road surfaces, tyre inflating pressures and vehicle speeds may lead to skid. Skid is very dangerous.

The optimum method to stop skid is lowering driving speed and keep cautious when you feel the road is wet enough.

Wading driving

In order to avoid damage to your vehicle, when passing a road with gathered water, please:

- Confirm the water depth before the wading driving. The maximum wading depth of the vehicle is 55cm.

STARTING AND DRIVING

- The driving speed shall not be greater than 10km/h.
- The wave caused by front vehicle and head-on vehicle may exceed the maximum allowed wading depth.
- To avoid vehicle damage, please drive away from the road with puddles as quickly as possible.

Caution

If the engine is shut down in the water by accident, do not restart the engine by yourself, please contact our Service Dealer immediately. When driving across water, the driver should always keep the intelligent start/stop system inactivated.



Water and mud can affect the braking system and lengthen braking distance, leading to an accident!

- Slightly depress the brake pedal to keep brake parts dry and recover performance.
- Do not conduct an emergency brake when passing a slippery road.

Note: The engine, drivetrain, transmission and electronic system of the vehicle may be severely damaged after the vehicle drives on a road with puddles. Salt water is corrosive. The on-board components soaked by salt water must be washed with clean water.

Catalytic converter



The catalytic converter will release a lot of heat (even within a short time after engine shutdown), which may cause a fire.

Do not operate or park the vehicle on any flammable object (such as paper, dry grassland or dry fallen leaves).

When the engine is running or after it is shutdown within a certain period, and before the catalytic converter cools down, prevent any body parts from contacting the exhaust system.

The catalytic converter installed in the exhaust system is used for reducing exhaust pollution.

Caution

In order to protect the catalytic converter from being damaged, the following precautions must be observed:

- Use the fuel suitable for your vehicle. The Company assumes no responsibility for the mistake of filling a wrong type of fuel. If you fill a wrong type of fuel carelessly, contact Our Service Dealer for service immediately. Do not start the engine.
- If the vehicle is difficult to start or driving performance degrades during driving, please drive the vehicle to a nearby Our Service Dealer for service.
- Do not drive under extremely low fuel level. The engine may be unable to start during driving under fuel exhaustion.
- Do not start the vehicle by pushing or trailing it.
- Do not shut down the engine during driving.

DPF (Diesel Particulate Filter)

The main function of DPF is to collect particles in vehicle exhaust, and to remove particles collected in DPF through active and triggered regeneration in a certain period to achieve the function of recovering DPF to collect particles. Active regeneration refers to the function of the engine to automatically start and recover DPF to collect particles in vehicle exhaust according to actual working conditions. Triggered regeneration refers to the regeneration that the current working conditions of the engine cannot meet the active regeneration conditions and requires human intervention.

Switching regeneration of DPF one-key regeneration

Instrument alarm prompt

Level 1 alarm prompt: "Please keep the vehicle speed at more than 60 km/h when safe and legal, or stop the vehicle and press the DPF key in the armrest box for regeneration" is displayed on the instrument cluster for 10 seconds, the buzzer sounds three times, and the "DPF (Diesel Particulate Filter) warning light (yellow)" on the instrument cluster



Stays ON.

Level 2 alarm prompt: "Please stop the vehicle and press the DPF key in the armrest box for regeneration in situ while ensuring surrounding safety" is displayed on the instrument cluster for 10 seconds, the buzzer sounds three times at an interval of 10 seconds, and the "DPF (Diesel Particulate Filter) warning light (yellow)" on the instrument cluster flashes at 1 Hz.

During regeneration, "xx% of DPF regeneration has been completed, please wait patiently" is continuously displayed on the instrument cluster, and the "DPF (Diesel Particulate Filter) warning light (yellow)" on the instrument cluster flashes at 0.5 Hz.

After regeneration, "Regeneration in situ is completed and normal driving is available" is displayed on the instrument cluster for 10 seconds, the buzzer sounds once, and the "DPF (Diesel Particulate Filter) warning light (yellow)" on the instrument cluster turns off.

If the regeneration cannot be accepted, "DPF cannot perform regeneration due to xx (Display the cause code), ** (Display the recommended operations to be performed by the user)" is displayed on the instrument cluster for 10 seconds, the buzzer sounds once, and the "DPF (Diesel Particulate Filter) warning light (yellow)" on the instrument cluster turns off. When DPF cannot perform regeneration due to xx (Display the cause code), the cause code and its corresponding cause are as follows:

- 1: Engine not started
- 2: Coolant failed to reach the proper temperature range
- 3: Oil failed to reach the proper temperature range
- 4: Failed to reach the proper ambient pressure
- 5: Fuel failed to reach the proper temperature range
- 6: Insufficient battery voltage
- 7: Clutch not released
- 8: Not in N gear
- 9: The vehicle speed is not equal to zero
- 10: Engine speed failed to reach the proper range

STARTING AND DRIVING

- 11: Engine torque failed to reach the proper range
- 12: Accelerator pedal not released
- 13: Upstream temperature of DPF failed to reach the proper range 1
- 14: Upstream temperature of DPF failed to reach the proper range 2
- 15: Upstream temperature of DOC (Diesel Oxidation Catalyst) failed to reach the proper range 1
- 16: Upstream temperature of DOC (Diesel Oxidation Catalyst) failed to reach the proper range 2
- 17: DPF particulates below the regeneration limit
- 18: DPF - related faults
- 19: Engine-related faults
- 20: Exceeded the maximum allowable regeneration time
- 21: Upstream temperatures of DOC (Diesel Oxidation Catalyst) and DPF failed to reach the target values within the allowable time range 1
- 22: Upstream temperatures of DOC (Diesel Oxidation Catalyst) and DPF failed to reach the target values within the allowable time range 2
- 23: Exceeded the maximum allowable temperature 1 of upstream DPF
- 24: Exceeded the maximum allowable temperature 2 of upstream DPF
- 25: Exceeded the maximum allowable temperature 1 of upstream DOC (Diesel Oxidation Catalyst)
- 26: Exceeded the maximum allowable temperature 2 of upstream DOC (Diesel Oxidation Catalyst)
- 27: Service station regeneration not activated
- 28: Brake pedal not released

Switching regeneration steps

- 1 Stop the vehicle, shift to P gear, activate the parking brake, and turn off the ignition switch for 2 minutes;
- 2 Start the vehicle;
- 3 Open the central armrest box, and then the one-touch regeneration switch panel. Press the one-touch regeneration switch and hold it for 2 seconds, then DPF regeneration will begin.

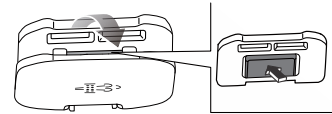

Note: If the engine speed rises to 2,000 rpm, the regeneration trigger is successful; otherwise it is unsuccessful. Turn off the ignition switch and wait for 2 minutes, and then operate again according to the above steps. Unless driving is necessary after regeneration starts, stay in P gear, and keep the vehicle stopped. Do not perform other operations (e.g. depressing the brake pedal, accelerator pedal, etc.) until the engine speed returns to idle speed.

Caution

DPF regeneration temperature is very high, please park the vehicle in an open and ventilated place, and make sure there are no inflammables (e.g. hay, oil, etc.) around when using. If it cannot be regenerated successfully for several times, please go to our Service Dealer for processing.

Conditions of regeneration

- The DPF is overloaded, and the particle value exceeds the set value (the instrument panel has level 1 and level 2 alarms).
- The water temperature is above 40 degrees Celsius.
- No DPF-related function error.
- The vehicle speed is 0, and the gear is P.

Possible causes of regeneration failure

- The gear is not in P.
- The vehicle is not stopped (the vehicle speed is not zero).
- The accelerator pedal is depressed.
- The brake pedal is depressed.
- The engine conditions are not satisfied (for example, the water temperature is too low and the exhaust temperature is too high).
- The engine has DPF - related fault (s).
- The regeneration steps were not followed.

Regeneration steps for high load driving

- 1 Carry out high-load conditions cycles, such as high-speed driving (vehicle speed is maintained at 60km/h and above);
- 2 Drive the vehicle for about 20 minutes.

Special driving conditions

Under the following circumstances, the vehicle has almost no triggered regeneration, and the efficiency of active regeneration is generally low or even zero, requiring the attention of the driver to try the best to avoid:

- Repeatedly start and stop the vehicle.
- Operate the vehicle at a low speed and a low load for a long time.
- The vehicle idles for a long time in stationary state.

Caution

The cumulative amount of DPF carbon deposition will increase after a long time idling. If your vehicle needs to keep operating at idle speed for a long time, when the active regeneration function of the vehicle is enabled, please depress the accelerator actively to make the engine speed reach 2,000 ~ 2,500 rpm to assist regeneration.

Fuel

Fuel Filler Cap

Before opening the fuel filler cap, please turn on the fuel filler flap opening switch (1)  on the driver's door first, and then open the fuel filler flap from the vehicle interior.

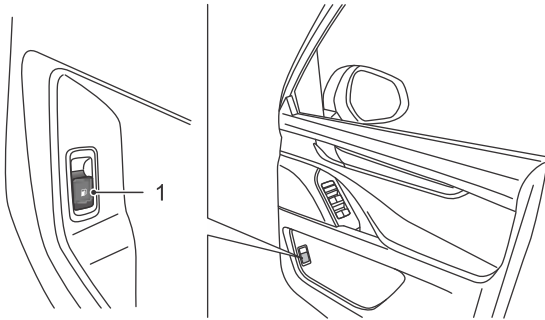

Rotate the fuel filler cap counterclockwise to remove it, and secure it on the bracket of the filler flap, then refuel. After refueling, 3 clicks need to be heard when tightening the fuel filler cap clockwise, which indicates that the fuel filler cap has been tightened in place, then close the fuel filler flap.

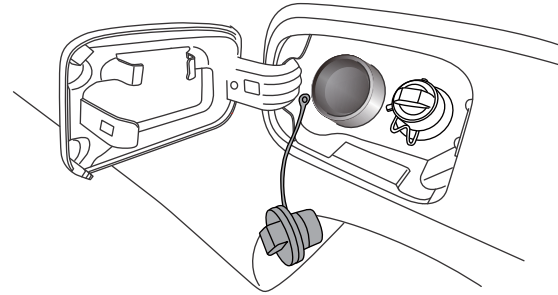

Refueling



It is prohibited to mix fuel with engine oil, kerosene, paraffin, water or other liquids for use, which may damage the fuel system.

Do not fill so much fuel that the fuel can be seen in the filling port or overflows, leading to a fuel contact risk for you and other persons.

Select the fuel to be added according to the label on the fuel filler port of vehicle's tank. Please refer to "Main Engine Parameters" in the General Technical Parameters section.

Caution

- It is recommended to use high-quality fuel free of additive or other engine cleaner.
- If you fill a wrong type of fuel by accident, contact our Service Dealer for service immediately. Do not start the engine at this time. If the engine is started with a wrong type of fuel filled, the fuel system components will be damaged severely. This kind of damage is not covered by warranty.



In order to prevent fuel from overflowing, please stop refueling when the fuel filler nozzle is automatically closed. If you continue refueling at this time, the fuel tank will be overfilled and the fuel will overflow when the outdoor temperature is high or the vehicle makes a turn.

Save Fuel

Fuel consumption is mainly influenced by three factors:

- Vehicle maintenance mode
 - Please go to our Service Dealer for regular maintenance of the vehicle in accordance with the provisions in the "Warranty and Maintenance Manual".
 - Check the tyre pressure periodically.
- Vehicle driving mode
 - Avoid high-speed driving at low gears (the gear shall be shifted), otherwise the vehicle will consume more fuel.
 - Frequent cold start and/or short-distance driving consumes a lot of fuel.
 - The vehicle will consume a lot of fuel when driving on a blocked or winding road or driving up hills.
 - Pre-consider possible risks to avoid emergency brake.
 - Make sure the parking brake handle is released completely during driving.
- Vehicle Load
 - The heavier the load is, the higher the fuel consumption is. Do not add unnecessary load.

STARTING AND DRIVING



The following driving precautions will help you to save fuel and protect the environment.

- Ensure the tyre pressures are correct.
- Avoid accelerating immediately after starting, and avoid depressing the accelerator pedal all the way down.
- The driving time at low gears shall not be excessively long.
- Try to use the top gear when the engine runs steadily.
- Pre-consider possible barriers, crossroads, sharp bends or traffic lights, and adjust vehicle speed correspondingly in advance.
- If it is predicted that the traffic may be blocked for a long time or it is required to wait for a long time, please shut down the engine if allowed by safety conditions.

Precautions for Cold Weather



It is prohibited to use lamp oil (kerosene) as the additive.

In order to reduce possible problems which may occur in cold weather, please consider the following suggestions:

- Please use the fuel conforming to winter requirements.
- Park the vehicle in an area which can maintain the fuel temperature above -9°C.
- Fill the fuel tank after driving every day. This practice will reduce the possibility of fuel condensation and accordingly reduce the influence of water generated due to temperature rise after condensation on oil quality.
- Replace the element of fuel filter according to the recommended time interval.
- Maintain the battery power in normal state.

Caution

Additive may degrade the lubricating property of fuel, accelerating wear and damage of engine and fuel injector.

Urea

When the "Urea Warning Lamp (yellow)"  on the instrument pack illuminates, the user needs to replenish the urea solution for motor vehicles in time. The urea solution for motor vehicles used needs to meet the standards of ISO22241-1 :2006.

Urea refilling



Do not mix urea with engine oil, kerosene, paraffin, water or other liquids, which may cause damage to the urea system. The rated volume of the urea tank is 17L. It is recommended to use a standard urea gun for refilling. The number of refills after the gun jumps must not be more than twice. If refilling urea with other simple tools, users need to refill according to their estimation on remaining urea. Do not refill too much urea, so that it can be seen or overflowed from the filling hole, posing a danger of coming into contact with urea to yourself and others.

Before opening the urea filler port, first open the fuel filler flap opening switch  located on the driver door, and open the fuel filler flap from vehicle inside. The urea filler port is located to the left of the fuel filler port.

Turn the urea filler cap counterclockwise, remove the urea filler cap to allow urea filling. After filling, tighten the urea filler cap clockwise, and then close the fuel filler flap.

Note: The color of the urea filler cap is blue, and the text on the cap is AdBlue.

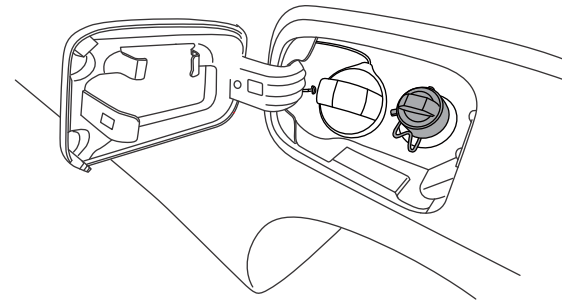

8AT Automatic Transmission

Gear

P (Park Gear)



Engaging **P (park)** gear during vehicle running will cause transmission damage. Do not use **P (park)** gear to replace the parking brake. Make sure the shift lever is at **P (park)** gear and the parking brake is completely set. The vehicle must be stopped completely before adjusting to **P (parking)** position. The transmission output gear is locked in this position to prevent driving wheel from moving.

P gear is used to assist in parking and starting the engine.

R (Reverse gear)



Fully stop the vehicle before shifting to/out of **R (reverse)** gear; shifting to **R gear** during vehicle running will cause transmission damage.

R gear is used to reverse.

N (Neutral gear)



When stopping temporarily in **N gear**, apply the parking brake or depress the brake pedal, otherwise there is a risk of slipping or accident.

Do not shift to **N gear** while driving.

N gear is powerless and the transmission system does not transfer any power.

D (Drive gear)

D gear is generally a forward gear. When driving normally, it is recommended to use **D gear**. The transmission can adaptively adjust the gear ratio for optimal economy.

M (Manual)

During acceleration for overtaking or driving uphill and downhill, it is recommended to use **M gear**.

Gear shift operation



Situation of the mass surrounding the vehicle especially children must be checked before shifting to D (drive) or R (reverse) gear. Make sure that the shift lever is in P (park) position, apply the parking brake and shut down the engine before leaving the driver seat.

To avoid damages to the transmission, do not accelerate the engine while depressing the brake pedal and shifting to R (reverse) or D (drive) gear. When parking on a slope, do not secure the vehicle with engine power. Please use the parking brake. When the engine rotates at a speed higher than 2,500rpm, do not shift from N (neutral) or P (park) gear to D (drive) or R (reverse) gear.

STARTING AND DRIVING

After the engine is started, normal gear shift operations can be performed.

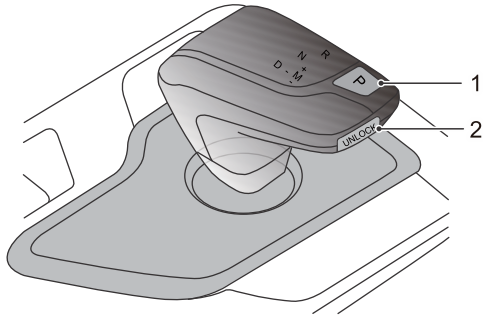

- 1 P gear button
- 2 Unlock button

Shift to P gear

When the vehicle is stationary, press the P gear button (1) to shift to P (park) gear.

Shift to R, N and D gear

- In P/D gear

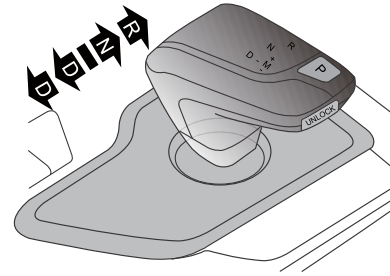

- In N gear

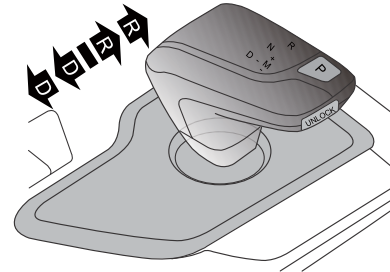

STARTING AND DRIVING

- In R gear

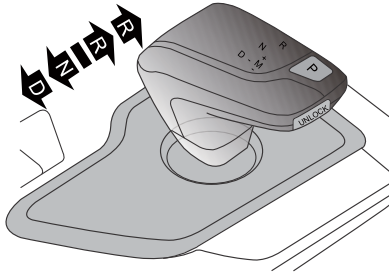

Push or pull the shift lever briefly in the desired direction (two positions forward and backward). When the shift lever is released, it will return to the neutral position.

When shifting from P (park) gear to R (reverse) gear, it is necessary to depress the brake pedal and press the unlock button (2); when shifting to D (drive) gear, it is necessary to depress the brake pedal.

The engaged gear will be displayed in the shift lever handle and instrument information center.

M gear (Manual)

 **M gear can be operated only in the automatic mode D gear; do not try to move the shift lever to the right in other gears.**

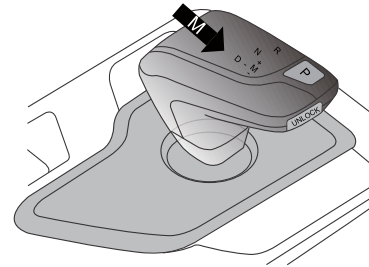

In the automatic mode D gear, move the shift lever to the right to switch to M gear and select the manual mode, and push or pull the shift lever forward or backward to change the gear. To return to D (Drive) gear, move the shift lever to the left D gear.

(+): Push the shift lever forward once to a higher gear.

(-): Pull the shift lever backward once to a lower gear.

The gear displayed in the instrument cluster will indicate the current gear of the vehicle with any of M 1 ~ M8.

Note: When the vehicle is completely stopped in M gear, press the P gear button to directly shift to P (park) gear.

STARTING AND DRIVING

Caution

If the gear shift time selected by the driver is inappropriate in the manual mode, such as upshifting while the engine speed is too low or downshifting while the vehicle speed is too high, the transmission will not respond, and the vehicle will still be driving in the original gear. When the vehicle is running in a certain gear, the transmission will automatically downshift to the next lower gear to prevent the engine from stalling if the engine speed is lower than a certain value. When the vehicle accelerates and the engine speed continues to rise and reaches the maximum speed allowed by the gear, if there is no upshifting request at this time, the transmission will automatically upshift to the next higher gear to protect the engine.

Temporary manual mode (steering wheel paddle)

Note: It applies to models with steering wheel paddle.

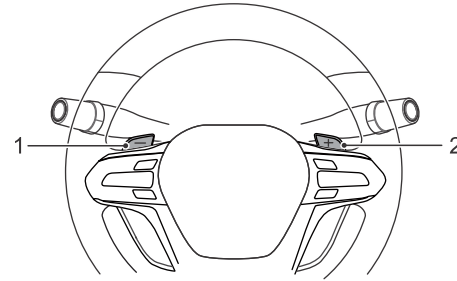

1 Downshift paddle

2 Upshift paddle

In the automatic mode D gear, operate the steering wheel shift paddle directly to enter the temporary manual mode. Upshift or downshift can be achieved by moving the paddle again. The gear displayed in the instrument cluster will indicate the current gear of the vehicle with any of D1 ~ D8.

STARTING AND DRIVING

Note: *In the manual mode M gear, upshift or downshift can also be achieved by moving the paddle.*

Caution

The temporary manual mode is for temporary use only, not a long-term manual state. If the shift paddle is not operated again for a period of time, the system will return to the automatic mode D gear.

Auto Park function

For safety, the transmission automatically shifts to P (Park) gear when powered off while the vehicle is in other gears than P.

When the vehicle is stationary, the transmission will automatically shift to P (Park) gear to prevent slipping if the driver does not wear the seat belt and depress the brake pedal and accelerator pedal while opening the door.

STARTING AND DRIVING

Manual release of P gear lock (Towing mode)

When the vehicle fails (dead battery, transmission controller failure and shifter failure, etc.), and cannot shift out of P (Park) gear, the transmission shall be shifted manually and forcibly from P (Park) gear to N (Neutral) gear for towing. Otherwise, the transmission will be damaged.

- 1 Go to the second row of seats, grab the lower edge of the rear panel of the auxiliary fascia console with both hands (as shown), and pull it toward the rear of the vehicle to remove the rear panel of the auxiliary fascia console.

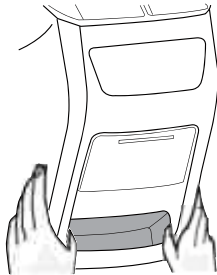

- 2 A yellow pull ring (1) and a metal bracket (2) can be seen after removal.

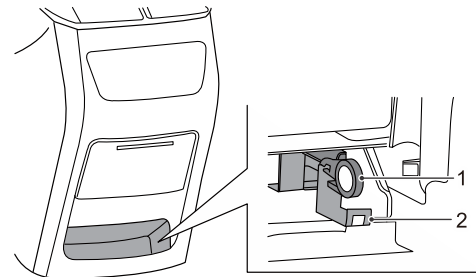

- 3 Pass your finger through the pull ring (1) and lift it up, then pull it backward, and stick the pull ring (1) on the metal bracket (2), so that the transmission is shifted from P (Park) gear to N (Neutral) gear.

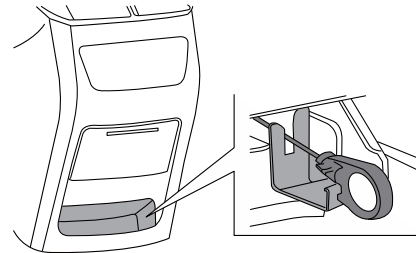

STARTING AND DRIVING

Caution

If the vehicle is powered up or started at this time, the instrument will prompt “P gear lock failure”, indicating that the transmission is in the P gear unlock state. The prompt will disappear when P gear unlock cable returns to its original position.

- 4 After moving the vehicle, perform the operation steps in the reverse order of the above method immediately for recovery to avoid forced release of the transmission P gear for a long time.

Note: If the manual P gear unlock is required, a problem has occurred in the vehicle. Please contact Our Service Dealer for service. Our professional service personnel will restore P gear unlock cable and the rear panel of the auxiliary fascia console to their original position.

Electric Power Steering Device

The electric power steering gear enables you to make a turn with less force.

When the steering system fails or the engine is turned off (towed by another vehicle), the driver can still maintain the full control over steering, but greater force shall be applied to operate the steering wheel.

Four Wheel Drive System (4WD)

All-Terrain Four Wheel Drive System (ATS)

ATS system optimizes the relevant control system between the powertrain, chassis and etc., controls the vehicle by operating the ATS knob, can provide help for users lack of off-road driving experience and can promote driving skills of users with rich experience in off-road driving. Users select the appropriate drive mode according to the road condition under different road conditions. ATS system can optimize all control system of the vehicle according to the drive mode selected by users to adapt the corresponding terrain. Not needing specialized knowledge, users can drive the vehicle easily and enhance effectively the trafficability, driving stability and off-road performance of the vehicle.







All-terrain four wheel drive system (ATS) switch is located on the floor console, and is used to select the AUTO (automatic), ECO (Economic), SNOW, MUD, SAND, and ROCK to switch. When a certain drive mode is selected, the corresponding prompts and indicator will be shown on the instrument cluster information center.

Precautions before Use

- When driving on a road which is dry and in good condition, if the SAND, MUD or ROCK mode is selected, the tyre wear will accelerate, and fuel efficiency will decrease. Meanwhile, it will increase vehicle noise level and cause damage to the powertrain system. Therefore, it is recommended to the appropriate drive mode according to road conditions.
- Large-angle turning is prohibited under the SAND, MUD and ROCK mode, otherwise it will easily damage the components of powertrain system and cause abnormal wear of tyre, even rollover accident in serious cases.
- It is prohibited to choose the SAND, MUD and ROCK mode on the road with high adhesion (urban road, expressway, etc.).
- Avoid driving the vehicle on sandy road or muddy road for a long time. If the vehicle drives on sandy road or muddy road for a long time, the overheat protection function of the system may be activated to quit out of 4WD state and switch to 2WD to protect the powertrain system.
- If "4WD MIL (red)"  on the instrument cluster information center illuminates, please go to our Service Dealer for inspection as soon as possible.
- To prevent the vehicle from slipping when it starts off on a snowy/icy road, it shall be started off in SNOW mode with the transmission at 2nd gear, so as to improve the start-off stability and safety of the vehicle.

STARTING AND DRIVING

Instructions for Switching All-Terrain 4WD System

Switch an Floor Console	ATS Mode Indicator	Drive Mode	Driving Conditions	ESP System	Constant Speed Cruise System	Adaptive Cruise System
ECO	ECO	ECO(Economy)	For general highways and expressways (2WD state and better fuel economy).	On by default	Available	Available
AUTO		AUTO(Automatic)	For general highways and expressways (real-time 4WD state).	On by default	Available	Available
SPORT		SPORT(Sport)	For general highways and expressways (real-time 4WD state, higher upshift/downshift speed and more adequate power reserve).	On by default	Available	Available
SNOW		SNOW(Snow)	For roads with low adhesion coefficient, such as roads with snow, grass, rain or snow days and etc.	On by default	Use is prohibited	Use is prohibited
MUD		MUD(Mud)	Non-pavement roads such as: roads with mud, deep ditches, loose or rough roads and roads with deep snow.	On by default	Use is prohibited	Use is prohibited
SAND		SAND(Sand)	Loose sandy road, dry sandy road/sandy bench/sand dune/desert and roads with deep gravel.	On by default	Use is prohibited	Use is prohibited
ROCK		ROCK(Rock)	Dry river channels, Gobi, great altitude difference, steep slopes and other poor road conditions.	Off by default	Use is prohibited	Use is prohibited

Caution

When switching into or out of the ROCK mode, be sure to stop the vehicle and shift the lever to N gear position. The switching to or out of the ROCK mode may take 3 - 5 seconds, please wait in patient until the instrument cluster information center shows the target mode, which indicates the switching is completed. Then, shift the transmission out of the N gear position. During the switching into the ROCK mode, the transfer case will perform 4L mode switching. If you continue rotating the ATS switch at the moment, the transfer case motor may be damaged, the ATS alarm function may be triggered and the 4WD ATS MIL may be illuminated by the instrument. If the ATS alarm function is triggered by accident, you can continue rotate the ATS switch slowly to other modes but the ROCK mode to cancel the failure warning state. **DO NOT** slam on the accelerator pedal to start the vehicle during the switching, or the transfer case may easily be damaged.

Switching between modes of ECO, AUTO, SPORT, SNOW, MUD and SAND

Place the ignition switch in "ON" mode.

When the ECO/AUTO/SPORT/SNOW/MUD/SAND switch on the floor console is selected, "The ECO/ AUTO/ SPORT/ SNOW/ MUD/ SAND mode has been selected" will be shown on the instrument cluster information center; when the switching is

completed successfully, "ECO/ AUTO/ SPORT/ SNOW/ MUD/ SAND Mode" will be displayed on the instrument cluster information center.

Switching between modes of

ECO/AUTO/SPORT/SNOW/MUD/SAND - ROCK

Stop your vehicle and place the ignition switch in "ON" mode.

For automatic transmission models, push the shift lever to N position when switching.

Note: Switching can be made after above-mentioned conditions are met.

When the ECO/AUTO/SPORT/SNOW/MUD/ROCK switch on the floor console is selected to switch the mode, if incorrect operations occur, relevant prompt information will be displayed on the instrument cluster Information center.

When switching is completed successfully, "ECO/AUTO/SPORT/ SNOW/MUD/ROCK Mode" will be displayed on the instrument cluster information center. ROCK is a special driving condition. There is a mechanical operation of gear movement in the transfer case when switching, which may cause the gear stuck. When "ROCK Mode" cannot be switched successfully, please drive the vehicle forwards or backwards slowly at the speed lower than 3km/h.

Electronic Differential Lock

The electronic differential lock (EDL) switch is located on the floor console, select the differential lock On/Off state with the EDL switch. The electronic differential lock can rigidly connect two half axles of rear wheels, when a rear wheel slips, the vehicle can still obtain a large driving force.

Precautions before EDL Use

- The EDL is suitable for slippery roads, such as roads with grass, mud, sand, mud pits and other bad road conditions. When driving on a road which is dry and in good condition, if the EDL mode is selected, the tyre wear will accelerate, the vehicle noise will increase, and it is easy to cause damage to drivetrain components, meanwhile risks in driving may exist, so it is recommended to turn off the EDL in this road condition.
- After the EDL is locked, the rear wheels are equivalent to a rigid axle connection, at this time, it is required to avoid large angle turning operation, otherwise it will easily damage the drivetrain components and cause abnormal tyre wear, and even rollover accident in serious cases.
- If the "EDL Indicator Lamp (yellow)"  fails to go out or illuminate when the user operates the EDL Switch, or the "EDL

Indicator lamp (red)"  illuminates, please go to our service dealer for inspection as soon as possible.

EDL Use Instruction

EDL Locking

When the wheel speed difference between two rear wheels is less than 10km/h, and the vehicle speed is less than 5km/h, long press the EDL switch for more than 2 seconds, and the "EDL Indicator Lamp (yellow)" on the instrument cluster illuminates, it indicates that EDL is successfully locked. When the wheel speed difference between two rear wheels is greater than 10km/h, or the vehicle speed is greater than or equal to 5km/h, long press the EDL switch for more than 2 seconds, EDL will not perform the locking operation, and "Please Slow Down to Lock EDL" will be displayed on the instrument cluster.

EDL Unlocking

When the EDL is in locked state, and the vehicle speed is less than or equal to 30km/h, long press the EDL switch for more than 2 seconds, and the "EDL Indicator Lamp (yellow)" on the instrument cluster goes out, it indicates that the EDL is successfully unlocked. When the EDL is in locked state, and the vehicle speed is greater than 30km/h (only for vehicles equipped with Real-time 4WD System and All-Terrain Four Wheel Drive System) or 60km/h (only for vehicles equipped with Part-time 4WD System), the EDL will be automatically unlocked, the "EDL Indicator Lamp (yellow)" on the instrument cluster goes out, it indicates that the EDL is successfully unlocked. And it will no longer be automatically locked after the vehicle speed drops.

Brake System

Service brake

Dual-pipeline hydraulic brake system



During driving, if one hydraulic pipeline fails, the "Brake

System Warning Lamp (red)"  on the instrument cluster will illuminate, the failure may lead to the increase of brake pedal stroke and applied force, a longer braking distance, and even the vehicle pulling to one side. **Do not try to restore the brake pedal pressure by the way of alternate press and release. If one brake pipeline has pressure failure, you must find out the cause. Please stop the vehicle immediately with care. Contact our Service Dealer for service immediately. Do not continue to drive.**

If one hydraulic pipeline fails, the other hydraulic pipeline will continue working.

General status



Ensure carpet or other objects will not hinder the operation of brake pedal.

Do not take the brake pedal as the foot rest, since It may lead to brake overheat, efficiency degradation and excessive wear. Excessive worn brake pad / brake shoe will emit harsh noise or whistle, brake efficiency may be affected when the brake is applied. Please contact our Service Dealer for service as soon as possible.

If the engine stops running due to some causes, brake booster will stop working after 2 pedal operations, to achieve the expected brake effect, a larger force shall be applied on the pedal. In this case, the brake distance may be longer.

If the vehicle is not frequently in use or parked in the garage for an extended period of time, the efficiency of brake system will also be reduced. Please contact our Service Dealer for service as soon as possible.

Wet conditions



When driving in a heavy rainy day or on a muddy road, the efficiency of vehicle brake system will decline significantly. At this time, while ensuring a safe distance with other vehicles, slightly depress the brake pedal intermittently to keep the brake friction components dry. In a extremely wet weather, it may be required to repeat above operation every few kilometers.

In winter, there may be frozen ice or accumulated salt content on brake pads and brake discs. Slightly depressing the brake pedal intermittently may remove the ice and accumulated salt content.

Driving down a steep slope



Overheated brake may reduce its brake efficiency, and lead the vehicle pulling to one side.

For a steep slope which requires to apply the brake constantly, a lower gear shall be selected before driving downhill to reduce the required brake force.

ABS (Anti-lock brake system)

ABS is used to prevent wheels from locking in an emergency brake, thus to help you maintain the control on direction, no special driving skills are required.

In normal brake (the road surface has enough friction to prevent wheels from locking), ABS will not be activated.

As an important part of brake system, electronic brake-force distribution system (EBD) is used to optimize the rear wheel brake force in full load.

Important rules for emergency brake with ABS On:

- 1 Completely depress the brake pedal.
- 2 Bypass the obstacle. No matter how much brake force is used, you can always maintain the control on direction.

ABS function



ABS may not be able to shorten the brake distance, depending on road surface conditions, brake distance may vary significantly. In fact, when the vehicle without ABS drives on some roads (e.g., gravel road or snowy road), the brake distance may be shorter.

When the vehicle runs at a high speed or wheels spin on slippery wet road (if there are water on the road surface, tyres will fail to fully contact with road), ABS can not provide a shorter brake distance due to some physical limits.

ABS can better protect yourself and other road users from unnecessary risks. But you are still obliged to observe general safety rules and consider road, weather and traffic conditions as appropriate.

If the brake force applied exceeds the adhesion between tyres and ground, which is enough to lock one or more wheels, ABS will automatically come into operation. You will hear a rapid vibration sound, and feel a slight vibration through the brake pedal.

Even when making emergency braking on a slippery road surface, be sure to fully depress the brake pedal. ABS is activated immediately and will continuously monitor the speed of each wheel, and change its brake pressure according to the friction available.

This can prevent the wheels from being locked to ensure the control on direction.

Precautions for driving a vehicle with ABS

- In case of emergency braking, fully depress the brake pedal.
- In case of normal braking, apply force steadily on the brake pedal, and do not adopt the rapid depressing and releasing alternatively.
- Please keep in mind that steering control is still available when braking.
- Some risks can not be eliminated with ABS, such as too close with the front vehicle in driving, driving on a slippery road, and excessive pursuit of speed in driving.
- ABS can not guarantee a shorter brake distance.
- Please take it easy if a slight brake pedal vibration is heard or felt. This is a normal phenomenon when the ABS is in operation.

ESP (Electronic Stability Program)

ESP function

ESP covers the functions of ABS, EBD, TCS, VDC, EBA, RMI, HAS, AUTO HOLD, ATS and HOC.

When the ESP is enabled, ESP indicator will blink on the instrument cluster. You may hear some noise or feel the vibration of brake pedal, it is a normal phenomenon. When the ignition switch is placed in "ON"

position, ESP indicator (yellow)  will illuminate, and go off after 3 seconds. In normal driving conditions, ESP indicator keeps off, and ESP is in monitoring state. When the ESP indicator blinks, it indicates ESP is operating. You may hear some noise or feel the operation vibration of brake pedal, it is a normal phenomenon. In case of ESP failure, ESP indicator will stay on. Please take the vehicle to our Service Dealer for ESP inspection.

ESP can be turned off with ESP OFF switch ,

after the ESP function is turned off, the "ESP OFF Indicator Lamp (yellow)"  illuminates, and only ABS and EBD functions are available.

EBD (Electronic Brake-force Distribution)

EBD automatically detects the grip conditions between wheels and ground, distributes the brake force optimally to 4 wheels, so as to improve brake efficiency and driving stability.

TCS (Traction Control System)

TCS automatically controls the driving force at the start-off and acceleration to prevent wheels from spinning, so as to maintain the driving stability.

VDC (Vehicle Dynamics Control)

VDC is an advanced computer system, which can help you to control the vehicle driving direction in severe driving conditions. When the computer detects the deviation between the expected driving route and the actual driving direction, VDC system may selectively apply brake pressure on one or more brakes of the vehicle so as to keep the vehicle driving in the direction commanded.

EBA (Electronic Brake Assist)

In case of an emergency, the force applied by a driver on the brake pedal is usually insufficient. EBA can identify this rapid action with insufficient force on the brake pedal and automatically establishes a brake pressure up to the lock level to shorten the brake distance greatly.

RMI (Roll Movement Intervention)

RMI can identify the vehicle rollover trend as early as possible by monitoring the turning angle of steering wheel and lateral acceleration, and apply braking to one or more wheels to prevent the rollover to the greatest extent.

HAS (Hill-start Assist System)

When the vehicle drives uphill, HAS can prevent the vehicle from sliding backwards after the driver releases the brake pedal. The driver has up to 1.5s to move his foot from the brake pedal to the accelerator pedal for hill-start.

AUTO HOLD

ESP and EPB function together, to help your vehicle to park in any static conditions, without the need of depressing the brake pedal all the time. Please refer to "AUTO HOLD" in this section for its specific use.

ATS (All Terrains System)

In different drive modes, ESP responds to different road conditions by its control on different torque requests of the engine and braking force. Please refer to "Four Wheel Drive (4WD)" in this section for more information.

HDC (Hill Descent Control)

When driving on a long downhill road with a relatively great gradient (4°-26°), if the vehicle speed is within 8-35km/h, there is no need for the driver to depress the brake pedal and accelerator pedal, and the vehicle will run at a low speed automatically, so as to ensure the vehicle goes downhill steadily, at this time, the driver may correct the speed with the brake pedal and accelerator pedal.

When the vehicle speed is less than 8km/h or within 35-60km/h, HDC does not work but is in standby state.

When the vehicle speed exceeds 60km/h, HDC function will exit automatically; to re-activate it, you need to press the HDC switch  again.

When the ignition switch is placed in ON position, HDC is in off state by default, and other functions of ESP are all in standby state. When the HDC switch  is turned on, the "Hoc Indicator Lamp (green)"



on the instrument cluster illuminates, and the HDC function is in monitoring state, at this time, if HDC works, the "HDC Indicator Lamp (green)" will blink; if the "HDC Indicator Lamp (yellow)" illuminates, it indicates that HDC has a malfunction. Please take the vehicle to our Service Dealer of our company for ESP inspection. When the HDC switch  is turned off, the "HDC Indicator Lamp (green)" on the instrument cluster will go out, and the HDC function is disabled.

Instructions on ESP Off in Rock Mode of 4WD system (only for ESP system of vehicles equipped with ATS)

To ensure the vehicle's breakout capability on the rugged and slippery roads, after the 4WD system confirms the switching to ROCK mode, the ESP system will be automatically turned off, and the "ESP OFF Indicator Lamp (yellow)" stays on, and the ESP OFF switch is disabled at this time. When the 4WD system confirms the switching out of the Rock mode, the ESP system automatically resumes on, and the "ESP OFF Indicator Lamp (yellow)" goes out. Please refer to "Four Wheel Drive (4WD)" in this section for the details about the ROCK mode of 4WD system.

STARTING AND DRIVING

Precautions for driving a vehicle with ESP

ESP can detect and analyze vehicle conditions and correct driving mistakes, to ensure safety by taking precautions measures. As everything has a upper limit, if a driver drives too fast exceeding the limit, all existing safety devices will be paralyzed.



EPB (Electronic Parking Brake)

The EPB switch (Ⓢ) is located in the switch group which is in front of the central armrest and at the lower left side of the shift lever, you can control the application and release of the parking brake with the EPB switch.

Precautions before EPB Use

- With the ignition switch in ACC/ON position, the EPB is always available. To prevent excessive battery discharge, when the vehicle is not running, avoid the repeated operation of the EPB switch. When the battery power is low, the EPB system cannot be applied or released.
- When starting on a slope, EPB can prevent the vehicle from inadvertent slip. EPB can be automatically released only when the traction force of the vehicle is greater than the slipping component force.
- When the normal braking operation of the vehicle fails, the emergency braking function can still brake the vehicle, refer to "Emergency Braking Function" in this section for details.
- A slight noise will be produced when the electronic parking brake is turn on or off, which is a normal phenomenon and does not have to be disturbed.
- When the vehicle power is interrupted, the parking brake can not be released in applied state, and can not be applied in release state, please connect to an external power supply.

STARTING AND DRIVING

- If the "EPB Indicator Lamp (red)"  fails to go out or illuminate when you operate the EPB switch, or the "EPB Malfunction Indicator Lamp (yellow)"  illuminates, and EPB can not be released with normal operation, please contact our Service Dealer.
- Do not apply the electronic parking brake on the road with a gradient above 30%, or the vehicle may slip. When parking on the ramp with a gradient which exceeds the limit, EPB can not fully brake the vehicle, at this time, the driver may prevent the slipping by depressing the brake pedal.

Vehicle Parking

Manual parking

- 1 When the ignition switch is in ON position or the engine is running.
- 2 The vehicle is in stationary state.
- 3 Pull up the EPB switch , the parking brake will be applied, when the "EPB Indicator Lamp (red)" on the instrument cluster illuminates, it indicates that the parking brake is applied successfully.
- 4 Move the shift lever in P gear when parking.
- 5 When the vehicle is on a ramp, please rotate the steering wheel to ensure that the vehicle is aligned with the road edge in case of slipping.

Auto Parking

When the engine is shut down for more than 3 seconds and the vehicle is stationary for more than 1 second, the parking brake is automatically applied, and the "EPB Indicator Lamp (red)" on the instrument cluster will illuminate, thus to prevent the vehicle from inadvertent slipping.

Caution

When the vehicle power is interrupted, the released parking brake can no longer be applied, in this case, please park the vehicle on a level ground and place the shift lever in P position to retain the vehicle.

Disabling of Auto Parking

In some special circumstances (for example, in a car wash or when the brake disc may be covered by ice in a cold weather), if you do not need the Auto Parking function of EPB, press and hold the EPB switch in 3 seconds after the ignition switch is turned off, allow the EPB to be in release state, and observe the "EPB Indicator Lamp (red)", if the lamp illuminates, the vehicle will not enable the Auto Parking.

Starting off

Manually release the EPB.

- 1 The ignition switch is placed in ACC/ON position.
- 2 Depress the brake pedal.

STARTING AND DRIVING

- 3 Press the EPB switch  to release the parking brake, when the "EPB Indicator Lamp (red)" goes out, it indicates the parking brake is released.

Automatic Release of EPB



When the vehicle is stopped and the engine is running, if shifting into a gear, then it is not allowed to depress the accelerator pedal at will. Otherwise the vehicle will move immediately on its own, a risk of accident may exist.

- 1 The ignition switch is turned on.
- 2 The driver wears the seat belt.
- 3 The transmission is shifted into a gear.
- 4 Depress the accelerator pedal. When starting off on a level or ramp road, depress the accelerator pedal, when the traction force is greater than the slipping component force, the parking brake will be automatically released, the "EPB Indicator lamp (red)" on the instrument cluster will go out, and the vehicle starts to move.

Emergency Braking Function

Pull up and hold the EPB switch to activate the emergency braking function. At the time, the vehicle will brake all four wheels by activating the hydraulic braking system, and its braking effect is just like depressing the brake pedal with a great force. Once the EPB switch is released or the accelerator pedal is depressed with a great force, the emergency braking will be suspended.

Caution

This function applies to the situation that the normal braking operation fails.

AUTO HOLD

The AUTO HOLD switch  is located in the switch group which is in front of the central armrest and at the lower left side of the shift lever, you can control the start assist system on or off with this switch.

When the vehicle often encounters the traffic lights or stop-and-go drivings, the AUTO HOLD system provides support for the driver to reduce driving fatigue. AUTO HOLD function allows the parking brake to be automatically released when the vehicle starts off, and automatically applied when the vehicle is stationary.

AUTO HOLD On

Caution

To turn on AUTO HOLD, the following conditions need to be met: the driver door is closed, the driver seat belt is fastened and the engine starts.

Press the AUTO HOLD  switch, the LED in the switch illuminates,

and the "AUTO HOLD Indicator Lamp (green)"  on the instrument cluster illuminates. After the vehicle is stationary, when the "AUTO HOLD Indicator Lamp (green)" on the instrument cluster blinks, AUTO HOLD is operative, and the driver may release the brake pedal. When AUTO HOLD is operative, firstly it will apply the ESP pressure retaining parking, if the vehicle is still in stationary state after 10

minutes, ESP will request the EPB clamping parking. The "AUTO HOLD Indicator Lamp (green)" goes out, and the "EPB Indicator Lamp (red)" illuminates.

When AUTO HOLD is operative, opening a door or unfastening a seat belt will activate the EPB, the "AUTO HOLD Indicator Lamp (green)" goes out, and the "EPB Indicator Lamp (red)" illuminates.

If you shift into a gear and depress the accelerator pedal as usual, the parking brake will be automatically released, and the vehicle starts off. The "AUTO HOLD Indicator Lamp (green)" on the instrument cluster stays on, and AUTO HOLD is in standby state.

AUTO HOLD Off

Press the AUTO HOLD  switch, the LED in the switch goes out, the "EPB Indicator Lamp (green)" on the instrument cluster goes out, and the AUTO HOLD function is turned off.



Do not apply AUTO HOLD on the road with a gradient above 30%, or the vehicle may slip.



When the "AUTO HOLD Indicator Lamp (yellow)"  on the instrument cluster illuminates, it indicates that the AUTO HOLD system has a malfunction, please go to our Service Dealer for inspection as soon as possible.

Warning lamp

The warning lamps related to the brake system are: "Brake System Warning Lamp (red)", "ABS Warning Lamp (yellow)", "EBD Warning Lamp (red)", "ESP Indicator Lamp (yellow)", "ESP OFF Indicator Lamp (yellow)" "EPB Indicator Lamp (red)", "EPB Malfunction Indicator Lamp (yellow)", "AUTO HOLD Indicator Lamp (green)" and "HDC Indicator Lamp (green)", please refer to "Warning Lamps and Indicators" in the Before You Drive section.

Constant Speed Cruise Control System



Cruise control can be dangerous where you can not drive safely at a steady speed. Therefore, do not use the cruise control on winding roads or in heavy traffic. It is also dangerous to use the cruise control system while driving on a slippery road. On such roads, fast changes in tyre traction can cause excessive wheel spin, and you could lose control. Do not use the cruise control on a slippery road.

Your vehicle may be equipped with the constant speed cruise control system. With the cruise control, you can maintain the vehicle speed at 40km/h or above without keeping depressing the accelerator pedal. The constant speed cruise control system does not work when the vehicle speed is less than 40km/h.

For safety's sake, when the vehicle is started, the constant speed cruise control system can only be enabled after valid brake signal is detected.

For vehicles with the traction control system or electronic stability control system, the system starts to limit wheel spinning when the constant speed cruise control system is working. In case of this situation, the cruise control will be automatically disabled.

Set Cruise Control



If the cruise control stays on when you do not use it, you may touch the button and accidentally enter the cruise state. Then you may get scared and lose control of the vehicle. Therefore, keep the cruise control switch "Off" until you need to use the cruise function.

The cruise control buttons are located on the steering wheel.

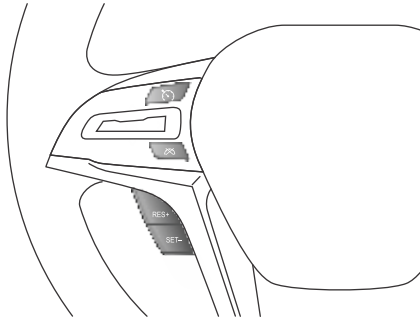

: Cruise on/off switch. Press this button to turn on/off the constant speed cruise control system. The "Constant Speed Cruise Indicator Lamp" on the instrument cluster will illuminate or go out.

: Cruise cancel switch. Press this button to cancel the cruise function without clearing the set speed in the memory.

RES+: Cruise recovery/acceleration switch. To store the set speed, press this button to recover this speed. Press this button again to accelerate (1 km/h per time).

SET-: Cruise setting/deceleration switch. Press this button to set the speed. Then the cruise function will be enabled and the "Constant Speed Cruise Indicator Lamp" on the instrument cluster will turn green from white. If the cruise function is enabled at this time, press this button to lower the cruise speed (1 km/h per time).

Set Speed

- 1 Press  to turn on the cruise control system. The "Constant Speed Cruise Indicator Lamp (white)" on the instrument cluster will illuminate.
- 2 Accelerate to the speed required.

Note: This speed must be higher than 40km/h.

- 3 Press SET- button and then release, the current speed will be stored and maintained, the "Constant Speed Cruise Indicator Lamp" on the instrument cluster will turn green from white.
- 4 Release the accelerator pedal, and then the vehicle will run at the speed set steadily. The cruise control function will be disabled when the brake is enabled.

Resume Set Speed

If you have set the cruise speed of constant speed cruise control system, the cruise control function will be disabled when you depress the brake pedal or press , but this set speed in the memory will not be cleared. To resume the pre-set speed, press RES+ button when the vehicle speed reaches 40km/h or above, and then the vehicle speed will be resumed to the pre-set value.

Accelerate with the Cruise Control System Enabled

There are two methods to accelerate:

- Accelerate by depressing the accelerator pedal.
- If the constant speed cruise control system has been enabled, press RES+ button and hold it until the vehicle accelerates to the desired speed, and then release it. To accelerate by minor increment, press RES+ button, and then release it. Every time this operation is done, the vehicle will speed up by about 1 km/h.

Decelerate with the Cruise Control System Enabled

If the constant speed cruise control system has been enabled:

- Press SET- button and hold it until the vehicle decelerates to the desired speed, and then release it.
- To decelerate by minor increment, press SET- button and then release it. Every time this operation is done, the vehicle will slow down by about 1 km/h.

Overtaking with the Cruise Control System Enabled



Speed up with the accelerator pedal. When you release the accelerator pedal, the vehicle will decelerate to the pre-set cruise control speed.

Applying Cruise Control on a Ramp

The performance of the constant speed cruise control system on a ramp depends on vehicle speed, load and gradient of the ramp. When the vehicle runs uphill, it may be required to depress the accelerator pedal to maintain the vehicle speed. When the vehicle runs downhill, it may be required to brake or shift to a low gear to maintain the vehicle speed. The cruise control function will be disabled when the brake is enabled.

Terminate the Cruise Control

There are three ways to disable the cruise control:

- Slightly depress the brake pedal once; the "constant Speed Cruise Indicator Lamp" on the instrument cluster will change from green to white when the cruise control is disabled.
- Press .
- Press  to turn off the constant speed cruise control system completely. The cruise control speed will not be resumed.

Clear Speed Memory

The cruise control set speed memory will be cleared when you press  or turn off the ignition switch.

Parking Assist System

Note: *The type of parking assist system equipped on your vehicle is subject to the actual vehicle configuration purchased.*

Reverse Radar Sensors

 **The parking assist system is not always reliable. It only plays the guiding role! Reverse radar sensors may be unable to detect certain types of barriers, such as fine objects like wire entanglement or rope, small objects close to the ground, tapered objects and some objects with unreflecting surfaces.**

Reverse radar sensors shall be free of dirt, ice and snow. Deposits on the surface of a reverse radar sensor will hinder the sensor's normal operation. Avoid spraying reverse radar sensors directly with high-pressure washer at a close range when washing the vehicle.

Four reverse radar sensors in the rear bumper scan the area behind the vehicle and judge whether there is any barrier. If detecting any barrier, the sensor will compute the distance between the barrier and vehicle rear end and remind the driver of the barrier through alarm sound signals. It is important to know that this system is a parking assist system only and cannot be regarded as a replacement for observation and personal judgment.

STARTING AND DRIVING

Operating state of reverse radar parking assist system:

When the R gear is selected and the vehicle speed is less than 15km/h, the system will activate the detection function.

Note: If the system keeps ringing for a long time after the gear is shifted to “R”, it indicates that the system has a malfunction. Contact our Service Dealer for service as soon as possible.

During reversing:

The alarm device will start making alarm sounds when the distance between the vehicle and a barrier behind it is about 1.5m. The shorter the distance between the vehicle and barrier is, the more hurried the alarm sounds are.

When the distance between the vehicle and the barrier behind it is less than 0.4m, the alarm device will make continuous alarm sounds. At this time, if you continue reversing, the barrier cannot be identified effectively.

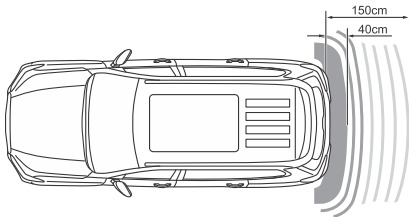

Front and rear radar sensors

! The parking assist system is not always reliable. It only plays the guiding role! Reverse radar sensors may be unable to detect certain types of barriers, such as fine objects like wire entanglement or rope, small objects close to the ground, tapered objects and some objects with unreflecting surfaces.

Reverse radar sensors shall be free of dirt, ice and snow. Deposits on the surface of a reverse radar sensor will hinder the sensor's normal operation. Avoid spraying reverse radar sensors directly with high-pressure washer at a close range when washing the vehicle.

Radar sensors in the front bumper scan the area in front of the vehicle, and four radar sensors in the rear bumper scan the area behind the vehicle, and judge if there is any obstacle. If any obstacle is detected, the sensor will calculate its distance from the vehicle, and communicate this information to the driver by sounding warning chimes. It is important to know that this system is a parking assist system only and cannot be regarded as a replacement for observation and personal judgment.

STARTING AND DRIVING

Operating state of reverse radar parking assist system:

When the D gear or N gear is selected and the vehicle speed is less than 15km/h, the system will activate the detection function, at this time, the front parking radar enables the audible and visual warning function, while the rear radar only enables the azimuth display function (mute).

When the R gear is selected and the vehicle speed is less than 15km/h, both the front and rear radar will activate the detection function, at this time, both the front and rear parking radar enable the audible and visual warning function.

Note: If the system keeps ringing for a long time after the gear is shifted to “R”, it indicates that the system has a malfunction. Contact our Service Dealer for service as soon as possible.

Note: For vehicles without entertainment system display screen but with the 360° Around-view System, there is no visual warning function for front/rear radar.

During reversing:

The device will begin to sound warning chimes when the rear of the vehicle is 1.5m away from the obstacle, or the front of the vehicle is 0.6m away from the obstacle, the shorter the distance with the obstacle is, the more hurried the warning chimes are.

When the distance between the vehicle and the barrier is less than 0.4m, the alarm device will make continuous alarm sounds. At this time, if you continue reversing, the barrier cannot be identified effectively.

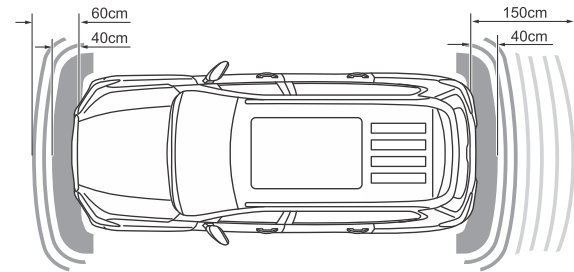

Reverse Cameras

! The reverse camera parking assist system is not always reliable. It only plays the guiding role! Reverse cameras have limited view ranges and cannot detect barriers outside the view ranges.

Operating state of reverse camera parking assist system:

After shifting the gear to R, the image of entertainment system display screen will be switched to the reverse camera operating state, and the entertainment system display will show the scene image behind the vehicle for the driver's reference during reversing.

When you place the shift lever in other positions, the reverse camera parking assist system will stop operating, and the entertainment system display screen will recover to the pre-reversing state.

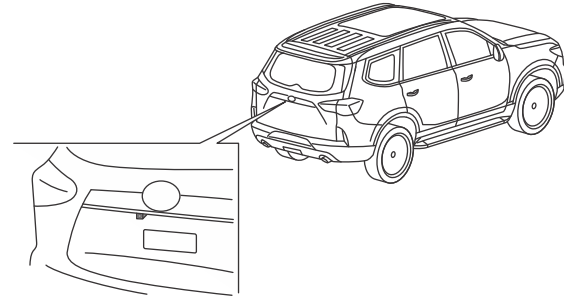

Note: When the vehicle enters the reversing state, cameras will output static reversing tracks which are displayed on the entertainment system display screen, take the horizontal plane as reference, and identify the area behind the vehicle in segments divided by red, yellow and green lines.

360° Around-view System

! The parking assist system is not always reliable. It only plays the guiding role! Reverse cameras have limited view ranges and cannot detect barriers outside the view ranges.

The 360° around-view system includes 4 cameras, which are respectively installed in the front, rear, left and right of vehicle body.

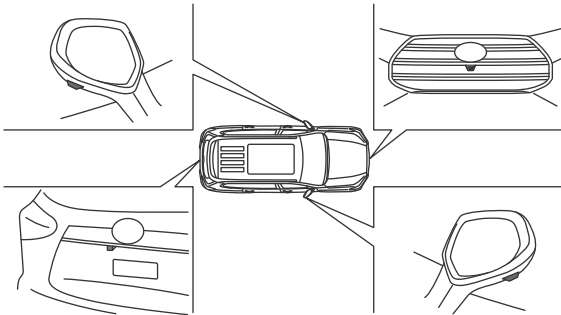

Operating state of 360° around-view system:

After shifting the gear to R, the entertainment system display screen will automatically switch to the 360° around-view interface, and then you can judge the relative position between the vehicle and barrier according to the image. Please refer to the Operating Instructions of the entertainment system mainframe.



When the vehicle speed is less than 15km/h, press the 360° around-view switch on the entertainment system display screen to turn on the 360° around-view system. Then the entertainment system display screen will switch to the 360° around-view interface of left turn, right turn or normal driving according to the current vehicle operation.

Note: Select the area to be viewed by touching the front, rear, left or right button on the entertainment system display screen.

Intelligent Semi-Automatic Parking Assist System

! The system is a parking assist system, which is not applicable in all cases, and can not completely replace the driver in driving and judgment, even if the system is running, the driver must be careful in driving and judgment, to avoid the risk of collision (Intervene steering wheel and brake if necessary).

Pull-In function (with D gear is selected)

- 1 Press the automatic parking switch  on the floor console to select the parking mode, the default is right-side parallel parking mode, press the  again to switch to perpendicular parking mode, after selecting the mode, it will enter the parking space search interface.



- 2 Choose left-side or right-side parking space search by turning on the turning signal lamps, search in the forward direction according to the instrument cluster information center display, and the parking assist

system searches for the parking space and determines whether the space is spacious enough; when an appropriate parking space is found, it will display the Parking Space Found interface, then the vehicle movement direction will be displayed in the instrument cluster information center interface.



- 3 Make gear shifts and control brake according to the prompts on the instrument cluster information center.

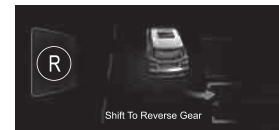

- 4 Park the vehicle, the instrument cluster information center shows "Parking Success" after the vehicle is successfully parked.

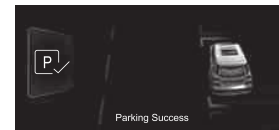

Pull-out function of parallel parking mode (with P gear is selected)

- 1 Press the automatic parking switch  on the floor console to switch to pull-out function, and switch the pull-out direction by turning on the turning signal lamps (Left pull-out is the system default).



- 2 After selecting the pull-out direction, if the system identifies by calculation that there is enough space for vehicle movement, the steering wheel will be taken over by the electronic steering system.

Steering Intervention,
Be Careful Of Ambient Enviroment



- 3 According to the driving direction, gear position and braking displayed in the instrument cluster information center, control the vehicle movement, to realize the semi-automatic pull-out.



Caution

During the parking, the system still maintains the radar detection warning chimes and obstacle azimuth display, to inform the driver of the obstacle information in real time to ensure the parking safety.

Intelligent Semi-Automatic Parking Assist System Exit

- Press the  button to exit the parking.
- Manually hold the steering wheel.
- When driving the vehicle to search a parking place, the vehicle speed is higher than 35km/h for more than 30 seconds.
- During the automatic steering, the vehicle speed is higher than 10km/h.
- The EPS system is invalid.
- The parking time exceeds 3 minutes.
- The steps (gear shift) during the parking exceeds 10.
- There is no obstacles and vehicle ahead when driving away from the park.

Precautions for Semi-Automatic Parking

- Before parking, please make sure there are no obstacles in the parking space, such as stones, thin pillars, tow bars or bicycles etc, as the system may not be able to detect such obstacles.
- When parking the vehicle in a parking place adjacent to the edge of the road with the intelligent semi-automatic parking assist system, the running track set by the system may go beyond the edge of the road, which results in damage to the tyres or rims of the vehicle by protruding road shoulder, so pay attention to the surrounding environment, control the speed, and make manual intervention if necessary.
- Do not clean the sensor with a high pressure cleaner or a steam cleaner to avoid sensor damage. In a vehicle wash, rinse the sensor surface with a small water flow in a short time, and keep a distance of at least 10cm above.

Driver Assist System

Note: *The type of driver assist system on your vehicle depends on the actual configuration of your vehicle.*

This vehicle is equipped with the multiple functions of the driver assist system, which can provide the following functions of the active driver assist system:

- Adaptive Cruise Control (ACC)
- Forward Collision Warning (FCW)
- Autonomous Emergency Braking (AEB)
- Lane Departure Warning (LDW)
- Blind Spot Detection (BSD)
- Parking Assist System

Camera of Drive Assist System

The camera of the drive assist system is used to realize the following functions:

- Adaptive Cruise Control (ACC)
- Forward Collision Warning (FCW)
- Autonomous Emergency Braking (AEB)
- Lane Departure Warning (LDW)

STARTING AND DRIVING

Restrictions for Cameras

There are some restrictions for the camera unit, which limit the function of the unit.

- Limited view



Like human eyes, the view of the camera is also limited, i.e. the camera will have poor sight in storm, blizzard, fog, severe dust storm or snowy weather, etc. In these situations, reliance on the function of the camera system may be reduced or released temporarily.

When using it to scan the lane, the strong oncoming light, reflection from the lane, ice and snow on the road, dirty or unclear lane line, etc may greatly degrade the function of the camera.

Do not place, post or install any article on the outside/inside windshield before or around the camera unit, this may interfere with the related functions of the camera.

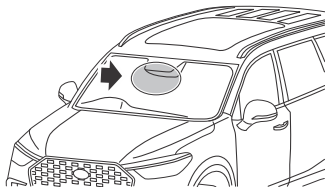

The camera unit is located at the upper side of the windshield, if the information center of the instrument cluster displays "Please Clean Windshield", "Camera System Failure", then the camera unit cannot detect other vehicles in front of the vehicle. The table below shows the example of the possible cause for the related fault displayed and the corresponding actions:

Cause	Action
The windshield before the camera unit has dirt or ice/snow.	Remove the dust, ice or snow on the windshield before the camera unit.
The view of the camera is blocked by fog, heavy rain or snow.	No remedy available. Sometimes, the recognition function of the camera unit is degraded in heavy rain or snow.
Dirt may occur between the inside windshield and the camera unit.	We suggest you drive to our Service Dealer for cleaning of the windshield in the unit cover.
Direct sunlight and strong oncoming light or severe road reflection.	No remedy available. Sometimes, the recognition function of the camera is degraded in strong direct sunlight.
Damaged camera unit hardware.	We suggest you drive to our Service Dealer for service.

- Damaged windshield

STARTING AND DRIVING



If the window before any camera unit of the windshield is cracked, scratched or damaged by stone impact, and the affected area is about 0.5x3.0mm or greater, then contact our Service Dealer for the windshield replacement and service. Failure to take any action may degrade the performance of the driver assist system using the camera unit. To avoid operation failure, insufficient or delayed operation of the driver assist system using the camera unit, please also follow the suggestions below:

- We recommend you replace the whole windshield instead of repairing the crack, scratch or damage by stone impact on the area before the camera unit.
- Before windshield replacement, please contact our Service Dealer to ensure you select and install an appropriate windshield.
- When replacing the windshield wiper, install the wiper of the same type or one approved by the Company.
- After windshield replacement, seek our Service Dealer to recalibrate the camera unit and ensure proper operation of the system functions based on the camera.

- Limited view

The camera unit has a limited view. In some cases, the camera cannot detect another vehicle, or the detection starts later than expected.

- On the curves, the ACC may respond to the vehicle in another lane, or it may not have time to respond to the vehicle in the same lane. In this case, the vehicle may collide with the front vehicle or be out of control. Particular care shall be taken for curves, and apply the brake when necessary. For driving on the curve, select an appropriate speed.

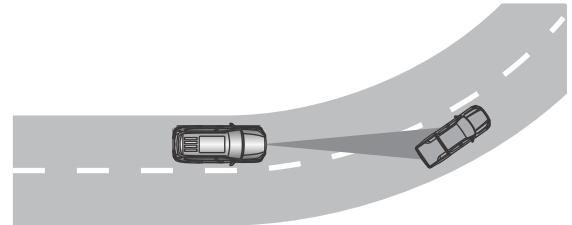

- When the vehicle from the adjacent lane drives ahead of your vehicle, if it is not within the detection range of the sensor, it cannot be detected by the sensor, this will delay the reaction of the ACC. The driver shall pay close attention to the action of the vehicle in the adjacent lane, and take active intervention when necessary.

STARTING AND DRIVING

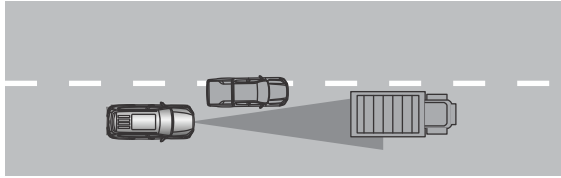

- Do not use the ACC on steep ramps. The ACC cannot detect any vehicle in the same lane on steep ramps. Normally, the driver shall control the acceleration and brake by himself on steep ramps. If the brake is applied, the ACC will be disabled. In addition, inaccurate speed control may occur when the adaptive cruise is applied on a sloped road.

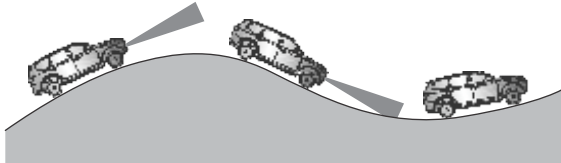

- The ACC cannot determine the accurate width of the front lane, so when the front lane is narrow, and the driver thinks that the vehicle cannot pass through it, the driver shall disable the ACC by brake intervention immediately and control the vehicle by himself.

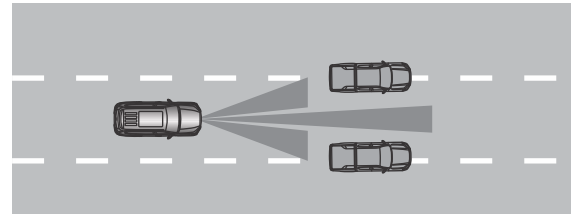

- The ACC cannot detect all kinds of vehicles on the road, especially for narrow vehicles, such as bicycle, motorbike, etc. The driver shall pay close attention to the narrow vehicle before the vehicle.

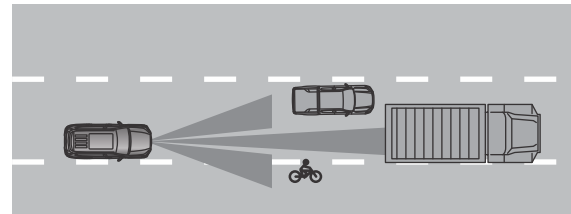

Adaptive Cruise Control (ACC)

The ACC helps the driver to maintain the same speed with the front vehicle and keep the preset interval. For long distance driving on the uncrowded motorway and long straight road, the ACC can allow you to enjoy a more comfortable and pleasant driving experience. The driver can set the desired speed and interval with the front vehicle. When the camera unit detects that the front vehicle slows down, the vehicle will automatically decelerate accordingly. When the front road is smooth again, the vehicle resumes to the set speed.



The driver shall always pay attention to the current traffic and intervene when the ACC does not maintain the correct speed or distance. The ACC cannot handle all traffic conditions, weather and road conditions.

Please read all sections related to the ACC in this Manual to understand the restrictions for this function, the driver shall master these restrictions before using the function.

The driver shall always assume the ultimate responsibility for maintaining a correct distance and speed, even if the ACC is enabled.

Overview

The distance between the vehicle and the front vehicle is measured by the camera unit. The ACC controls the speed by accelerating and braking. When the ACC applies the brake, the brake will give a low noise, this is a normal situation.

The purpose of the ACC is to follow the front vehicle in the same lane at the interval set by the driver. If the camera unit cannot see any front vehicle, then the speed set/stored by the driver will be maintained. If the speed of the front vehicle exceeds the speed stored, the above may occur.

The purpose of the ACC is to control the speed steadily. When emergency braking is required, the driver shall apply the brake by himself. Also when the driver of the front vehicle suddenly depresses the brake, this involves large speed variation. Accidental braking or brake failure may occur due to restrictions for the camera unit.

The ACC is able to follow another vehicle at the speed from stationary to 150km/h.



The ACC is not an anti-collision system. If the system does not detect the front vehicle, then the driver shall intervene.

The ACC does not take the brake invention for human or animal and small vehicles, such as bicycle, motorcycle, electric bicycle, including drop frame trailer, approaching, slowly moving or stationary vehicles and animals.

! Do not use the ACC for city traffic, intersection, slippery road, flooded or muddy road, overcast, rainy/ snowy weather, poor visibility, twisted road or entrance/ exit of the motorway.

The driver assist system is not suitable for the situations when the sunlight slants to the camera from the front; when entering/leaving the tunnel and when the main beam of the coming vehicle shines on the camera at night.

Switches of ACC

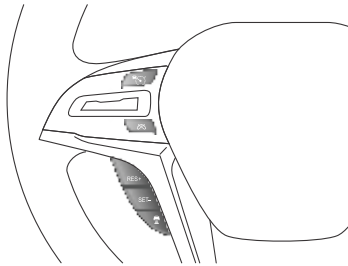

 ACC master switch, press it to turn on/off the system.

When the ACC is On:

 ACC exit switch, press it to turn off the ACC without clearing the set cruise speed.

RES+ : Increase the stored speed or re-activate the adaptive cruise control and resume the stored speed .

SET- : Decrease the stored speed or activate the adaptive cruise control and store the current speed.

 : Vehicle-to-vehicle distance setting, adjust the vehicle-to-vehicle distance of the adaptive cruise control, the vehicle-to-vehicle distance will be cycled among level 1-3 by each press.

Instrument cluster display



 : Vehicle-to-vehicle distance setting.

 : ACC state.

 : Target cruise speed.

 Ahead vehicle indicator lamp. When your car is a safe distance from the vehicle ahead of you, the ahead vehicle recognition indicator displays a solid green light; when your car is too close to the vehicle ahead, the ahead vehicle recognition indicator displays a solid yellow light.

STARTING AND DRIVING

Information center display of instrument cluster

! The ACC gives warning only to the vehicles detected by the camera, so it may not send an alarm, or there may be a certain delay for the alarm. When braking is required, apply the brake before receiving the warning.

When there is a potential risk of collision, the information center of the instrument cluster will give prompts:

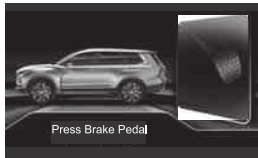

The ACC can use about 40% of the braking capacity of the foot brake, if the front vehicle suddenly brakes on the motorway, the ACC cannot decelerate the vehicle to a safe speed range, then the instrument cluster will display “Press Brake Pedal”, the driver shall take the brake intervention immediately.

Enable/disable ACC

When using the ACC to control speed, enable it first.

Enable ACC

- When pressing the master switch of the ACC  the instrument cluster displays:



It indicates the ACC is in STANDBY mode, ahead vehicle indicator lamp depends on whether the front vehicle is detected by the camera system.

To enable the ACC the following requirements shall be met:

- The seat belt of the driver seat shall be properly fastened, and the driver door shall be closed.
- When the speed of the front vehicle shall achieve at least 30km/h,
- With the ACC in normal STANDBY mode, press the steering wheel button SET-, When the ACC is enabled, the instrument cluster displays:



Current speed is saved to the memory as the desired speed and it is displayed on the speedometer in digital.

Note: If the information center of the instrument cluster displays *Cruise Not Available*, then the camera unit cannot detect other vehicles in front of the vehicle or the conditions for the ACC are not met.

Set ACC speed

Different ACC speed can be set. When the ACC is enabled, the cruise speed can be changed by the button on the steering wheel.

- Short press or long press the button on the steering wheel RES + or SET- button to change the speed saved:
 - Short press the button to change the speed at +/- 5km/h: one press of the button can change +/- 5km/h.
 - Change at +/- 1km/h, hold the button, and release it when the indicator of the driver display indicates the speed required, the value pressed for the last time will be saved to the memory.

If the driver accelerates by the accelerator pedal before pressing the button on the steering wheel, then the speed saved by the button becomes the vehicle speed, provided that the driver's foot locates on the accelerator pedal at the moment the button is pressed.

Use the accelerator pedal to accelerate temporarily, for example, this will not affect the set speed during overtaking. When the accelerator pedal is released, the vehicle resumes the speed saved for the last time.

Caution

The minimum set speed of the ACC is 30km/h, i.e, this speed allows the ACC and another vehicle to decelerate till they stop, but the speed below 30km/h cannot be selected/stored.

Note: When the ACC is enabled, increase the vehicle speed by the accelerator pedal, during the period from depressing the accelerator pedal to releasing the pedal, the cruise control will be disabled, and the information center of the instrument cluster displays Accelerator Applied, Cruise Control Failure.

Interval for setting ACC

Different ACC intervals can be set.

Different intervals can be selected for the front vehicle, which are displayed as 1-3 horizontal lines on the information center of the instrument cluster: the more lines there, the longer the interval will be. One line represents the interval between the vehicle and the front vehicle is around 1.5s, and 3 lines indicate the interval is around 2.5s. This sign will also be displayed when the distance warning function is activated.



Note: When the ahead vehicle indicator lamp is displayed, the ACC follows the front vehicle at the interval preset.

When the ACC is activated, use the button on the steering wheel to set the vehicle-to-vehicle interval, the default value is level 3.

STARTING AND DRIVING

- When pressing the  button on the steering wheel, the vehicle-to-vehicle interval will shift within level 1 - 3 in a circular manner.

In some cases, the ACC allows the interval to change dramatically so that the vehicle can follow the front vehicle steadily and comfortably. For short distance driving at low speed, the ACC will slightly increase the interval.



Caution

In case of any unexpected situation, short interval requires the driver to respond or act within a short period of time.

Note: The higher the speed is, the longer the distance (m) within a given interval is.

Disable/cancel ACC

You can disable the ACC for a short time, set it to the STANDBY mode and reinitialize it later or just cancel the function.

- When pressing the  button on the steering wheel, the Acc indicator  on the instrument cluster changes from green to white. Enable the ACC and set it to the STANDBY mode, cancel the function for a short time and set it to the STANDBY mode.
- When pressing the  button on the steering wheel, the ACC function is fully disabled, the cruise control speed will not be resumed, the ACC indication on the driver display will disappear.

Standby mode under driver intervention

Under the following situations, you can disable the ACC for a short time and set it to the STANDBY mode:

- Apply foot brake

Use the accelerator pedal to accelerate temporarily, for example, this will not affect the settings during overtaking; when the accelerator pedal is released, the vehicle resumes the speed stored for the last time.

Reactivate ACC at STANDBY mode

Press steering wheel button RES+, then, the vehicle speed is set to the speed stored lately.

Caution

When the speed is resumed by the button on the steering wheel, the vehicle accelerates significantly.

Auto STANDBY mode

The ACC is dependent on other systems, for example, ESP. If any system stops functioning, then the ACC will be disabled automatically.

In this case, the system sends an acoustic signal and the driver display will show a message. The driver shall intervene and match the speed and distance between the vehicle and the front vehicle.

The cause for auto deactivation:

STARTING AND DRIVING

- When the vehicle speed is below 5km/h, and the ACC cannot be sure whether it is a stationary vehicle or other objects in the front, for example, speed hump.
- When the vehicle speed is below 5km/h, and the front vehicle is turning, and the ACC stops to follow the vehicle.
- The driver door is open.
- The driver seat belt is unfastened.
- Low/high engine speed.
- The wheels lose grip.
- Hot brake.
- Apply the parking brake.
- ESP function is activated.
- When the ESP is OFF (i.e. press the ESP OFF switch, the indicator on the switch will illuminate, the ESP OFF indicator on the instrument pack will illuminate, and the ESP system will be turned off).
- The camera unit is affected by direct sunlight or its capacity for identifying oncoming strong light is degraded.

Target change and auto braking by ACC

At some speed, the ACC can change the target and brake.

Target Change

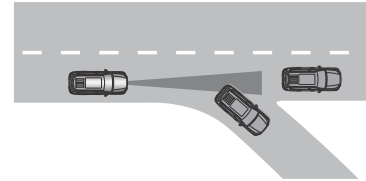

If the front target vehicle turns suddenly, the front traffic might be stationary. When the ACC follows another vehicle at a speed below about 30km/h, and the moving target vehicle becomes stationary, the ACC will brake according to the stationary vehicle.

! When the ACC follows another vehicle at a speed above about 30km/h, and the moving target vehicle becomes stationary, the ACC will ignore the stationary vehicle and select the speed stored. Then, the driver shall intervene actively and apply the brake.

Disable the ACC and set it to the STANDBY mode:

- When the vehicle speed is below 5km/h, and the ACC cannot be sure whether the target object is a stationary vehicle or other objects, for example, a speed hump.

STARTING AND DRIVING

- When the front vehicle is turning at a speed below 5km/h, the ACC stops to follow it.

Auto Braking

For short stay related to slow motion at slow traffic or traffic lights, if the stay is less than 3s, the driving resumes automatically. If the front vehicle starts to move after a long period of time, then the ACC will be set to STANDBY mode by auto braking.

Enable the ACC by one of the following methods:

- Press steering wheel button.
- Depress the accelerator pedal.

Caution

The ACC allows the vehicle to stop for at most 10 min. Then the parking brake will be applied, and the ACC will be disabled. The ACC can be enabled only when the parking brake is released.

Cancel auto braking

In some cases, the auto braking stops after it is stationary, and the ACC enters into the STANDBY mode. This will cause the brake to be released, and the vehicle may start to move, so the driver shall intervene and brake manually to maintain the original state.

This may occur under the following conditions:

- Place your foot on the brake pedal.

- Apply the parking brake.
- Shift to P, N or R gear.
- The ACC is set to the STANDBY mode by the driver.

Auto Activation of Parking Brake

Under some circumstances, apply the parking brake to stop the vehicle. This may occur when the ACC keeps the vehicle stationary, and:

- The driver door is open or the driver seat belt is unfastened.
- The ACC keeps the vehicle stationary for about more than 5min.
- The brake is hot.
- The engine is OFF.

STARTING AND DRIVING

Restrictions for ACC





The ACC will be restricted under some situations. Always use the ACC on level roads. When driving on the steep downhill under heavy load, it is hard to keep a correct distance between your vehicle and the front vehicle by this function, in this case, you shall take particular care and get ready for braking.

Applying Cruise Control on a Ramp

The performance of cruise control system on a ramp depends on vehicle speed, load and gradient of the ramp. When the vehicle runs uphill, it may be required to depress the accelerator pedal to maintain the vehicle speed. When the vehicle runs downhill, it may be required to brake or shift to a low gear to maintain the vehicle speed.

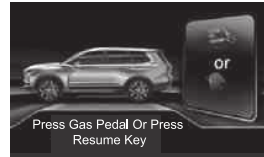
Symbol and Message of ACC

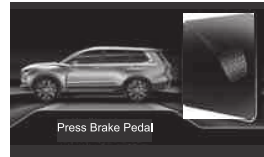
The information center of the instrument cluster will display some symbols and messages related to the ACC.

Symbol	Message	Meaning
	Please slightly depress the accelerator pedal or press the RES+ button	Restart the ACC at the STANDBY mode.
	Accelerator Applied, Cruise Control Braking Failure	If you depress the accelerator pedal when the ACC is enabled, the function will fail automatically.
	Press Brake Pedal	The driver shall intervene.
	Camera System Failure	The system is in abnormal state. Please contact our Service Dealer for service.
	Cruise Unavailable	The system is not available for the moment.

FCW and AEB

The FCW alerts the driver of the front vehicle by visual and acoustic signals. If the driver fails to take actions within a rational time, the system will trigger the AEB automatically.

The FCW can prevent collision or decrease collision speed, providing aid when there is a risk of collision with other vehicles. The AEB is an auxiliary function which helps the driver to avoid collision at traffic jams, for example, when an accident may occur due to change of the front traffic or distraction. When a collision is going to happen, the function can provide aid for the driver by applying the brake automatically when the driver does not apply the brake and/or when he/she does not avoid an obstacle due to slow action.

The AEB provides short, quick braking and it stops the vehicle under normal situations, exactly behind the front vehicle. For most of the drivers, this is not a normal driving style, so they may feel uneasy.

The AEB is enabled only when the driver applies the brake in advance, therefore, it cannot help the driver in all cases. To avoid unnecessary intervention, the design of the AEB requires late initiation.

Normally, the driver or passenger notices the AEB only when a collision is coming.

The AEB can decrease the vehicle speed to 40km/h at most, this avoids collisions with the front vehicle.

If the speed difference is higher than 40km/h, then the AEB cannot avoid the collision automatically. To completely avoid the collision in this situation, the driver shall apply the brake in advance.



The AEB shall not be the reason for the driver to change the driving style at will. If the driver totally relies on the AEB, a collision will happen sooner or later.

Enable FCW and AEB

Set in the vehicle state mode in entertainment system: Vehicle State Mode→Vehicle Control→Driving Assist; Options: OFF/Alann/Alann + Auto braking.

The FCW and AEB perform three procedures in the sequence below:

1 Collision Warning

First warn the driver of a possible collision. The FCW can detect stationary vehicle or vehicle moving in the same direction before the driver's vehicle. When there is a risk of collision with other vehicles, the vehicle will alert the driver via the blinking "FCW/AEB

Warning Lamp (yellow)"  acoustic signal and mild tactile warning in the form of cadence braking. For low speed, emergency braking or acceleration, no tactile warning is provided.

2 Brake Support

If the risk of collision has already escalated, then the auxiliary brake will be enabled. If the system thinks the braking force is not sufficient to avoid the collision, it will strengthen the braking force of the driver by the auxiliary brake.

3 Auto Braking

The auto braking is enabled at the final step. In this case, if the driver still does not take any anti-collision action, and a collision is going to happen, then the auto braking will be triggered. This happens whether the driver applies the brake or not. Apply the maximum braking force to reduce collision speed, or apply a limited braking force sufficient to avoid a collision. When the AEB successfully avoids a collision with the static object, the vehicle will come into a standstill to expect for the driver's action. In the event that the slow speed of the front vehicle causes the vehicle to stop, the vehicle speed will be decreased to the same level as the front vehicle. The driver can stop the brake intervention by depressing the accelerator pedal at any time.

Caution

When AEB applies the brake, the brake lamps illuminate

When the AEB is enabled and the brake is applied, the "FCW/AEB"

Warning Lamp (red)"  on the instrument cluster will illuminate, and it will send an acoustic alarm to indicate that the function is enabled or has been initiated.



The AEB is just an auxiliary function, so it cannot work under all driving conditions, traffic, weather and road conditions. The alarm is triggered only when a collision is likely to happen. Before using the AEB, the driver shall read this section to understand the specified restrictions.

The auto braking function of the AEB can prevent collision or decrease collision speed. To ensure a full braking performance, the driver shall always depress the brake pedal, even for auto braking.

The AEB will not enable the auto braking option under heavy acceleration. The driver shall always keep a correct distance and speed, and never wait the system to send a collision warning or the AEB takes an intervention.

Sensitivity Setting of FCW

With the FCW enabled, set the sensitivity.

Set in the vehicle state mode in entertainment system: Vehicle State Mode→Vehicle Control→Driving Assist; Options: High/Medium/Low.

The sensitivity determines the warning distance of the system and controls the distance triggered by visual, acoustic and tactile warnings. If the warning is excessive or it disturbs the driver, reduce the sensitivity. This will cause the system warning to occur later and the number of the warning to be decreased.



When there is a risk of collision, the FCW will send a warning to the driver, but this function cannot shorten the response time of the driver. To ensure the function of the AEB, high sensitivity is recommended for all drivings.

In some cases, the driver may be aware of the warning later even if high sensitivity is set, for example, when the speed changes dramatically or when the front vehicle stops suddenly.

No automatic system can work 100% under all conditions. Therefore, never driver around the pedestrian or vehicle when testing the FCW/AEB, this can cause serious damage and casualty.

Obstacle Detection by FCW and AEB

The FCW/AEB can detect obstacles such as vehicle.

Vehicle

The FCW/AEB is able to detect most of the static vehicles and the vehicle moving in the same direction. To ensure the FCW/AEB can detect vehicles at night, the headlamp and tail lamp shall work properly.

Bicyclist (FCW only)

The best example of what kind of target will be considered as a bicyclist by the FCW/AEB is as follows:



Clear outline of the body and bicycle.

To make the best use of the system, the system function for bicyclist detection shall try to acquire accurate information about the outline of the human body and bicycle, this means the system can identify the bicycle, head, hand, shoulder, thigh, upper body and lower body by combining the standard movement of the human.

If the camera cannot capture a larger part of the bicyclist's body or bicycle, then the system is unable to detect the bicyclist. To detect the bicyclist, he/she must be an adult and the bicycle must be an adult bicycle.

Restrictions for FCW and AEB

The FCW/AEB will be limited for some cases.

Ambient environment

- Low object

Dropping object, for example, the flag/pennant used to mark the cargo or accessories higher than the engine cover such as auxiliary lamp and bumper, will restrict the function.

- Skid

The brake distance will be prolonged on wet and slippery roads, this can degrade the anti-collision capacity of the AEB. Under these conditions, the anti-lock brake and ESP will apply the optimum braking force and maintain the stability.

- Oncoming Light

The visual warning signal on the instrument will be ignored when there is strong sunlight, reflection or when the driver wears sunglasses, or when the driver does not look straight ahead.

- View of Camera Unit

The view of the camera is limited, so it cannot detect any vehicle for some cases, or the detection result will come later than expected. In dark night, the time for detecting dirty vehicles may be longer than that for other vehicles. If the text message on the driver display indicates that the camera unit is blocked, the FCW/AEB cannot detect the vehicle or road line before the vehicle. This indicates a possible degradation of the functionality of the FCW/AEB. However, blockage of the windshield sensor does not necessarily cause an error. Therefore, the driver shall ensure the area before the windshield and camera unit is free from any obstacle.

Driver Intervention

- Reverse

When reversing your vehicle, the FCW/AEB will be disabled for the moment.

- Low Speed

The FCW/AEB will not be enabled at low speed (below 8km/h), and the system will not intervene when the driver approaches the front vehicle at a low speed, for example, when parking.

- Active Driver Action

The command of the driver always takes the priority, so the FCW/AEB will not intervene or delay the warning/intervention when the driver turns the steering wheel and accelerates, even if the collision cannot be avoided. Active and conscious driving style can delay collision warning and intervention time and minimize unnecessary warnings. When the driver actively turns off the ESP (i.e. press the ESP OFF switch, the indicator on the switch will illuminate, the ESP OFF indicator on the instrument pack will illuminate, and the ESP system will be turned off), the AEB will not intervene.

STARTING AND DRIVING

! If the camera unit fails to detect the vehicle accurately due to any traffic condition or external factor, then the system may delay or cancel the warning and brake intervention.

To detect the vehicle at night, the headlamp and tail lamp shall work and provide bright light.



Warnings for static vehicle or slow moving vehicle will be cancelled due to darkness or poor visibility.

When the vehicle speed is higher than about 80km/h, the warning and brake intervention for the vehicle will be disabled.

Do not place, post or install any article on the outside/inside windshield before or around the camera unit, this may interfere with the related functions of the camera.

Symbol and Message of FCW/AEB

The information center of the instrument cluster will display some symbols and messages related to the FCW/AEB.

Symbol	Message	Meaning
	FCW System OFF	The acoustic warning and light warning of the FCW is off.
	FEW System OFF	The AEB is off
	FCW/AEB Alarm	FEW Yellow Flash. AEB Red illuminate.

Lane Departure Warning (LDW)

The purpose of the LDW is to warn the driver to reduce the risk of unexpected departure on the motorway or similar road for some cases.

- Lane Departure Warning (LDW): the system warns the driver by acoustic signal and light signal.

The LDW will be enabled when the vehicle speed is within 60 ~ 150km/h and the road line is visible.

The function cannot be used on narrow roads, in this case, it will enter into the STANDBY mode. The function will work again when the road is sufficiently wide.

LDW interface:



Activating warning (LDW): if the vehicle is about to go across the lane line, the system will warn the driver by acoustic signal and light signal.

When the direction indicator lamp illuminates, warning from the lane assist system will be received.



The Lane Departure Warning is just an auxiliary function, so it cannot work under all driving conditions or traffic, weather and road conditions. The driver shall always hold the ultimate responsibility for driving safety and observe the applicable laws and road regulations.

Enable/Disable

The LDW can be set/canceled the function by the Personalization option of the entertainment system, or enable/disable the function by the LDW switch  on the auxiliary instrument platform.

When the system is enabled, the display interface of the information center of the instrument cluster is as follows:



White lane markings are displayed in the instrument cluster information

center interface. The LDW warning lamp  illuminates white.

When the vehicle runs at a speed above 60km/h and the system detects the left/right lane line, green lane line occurs on the display interface of the information center of the instrument cluster, the LDW warning

STARTING AND DRIVING



lamp will illuminate in green. At this time, if the vehicle departs from the original lane line without turning on the direction indicator lamp, this warning lamp will flash in yellow with buzzer alarm.

Sensitivity Setting of LDW

When the LDW function is enabled, its sensitivity can be set.

Set in the vehicle state mode in entertainment system: Vehicle State Mode→Vehicle Control→Driving Assist; Options: High/Medium/Low.

The sensitivity determines the warning distance of the system and controls the distance triggered by visual, acoustic and tactile warnings. If the warning is excessive or it disturbs the driver, reduce the sensitivity. This will cause the system warning to occur later and the number of the warning to be decreased.

Blind Spot Detection (BSD)



The BSD is not always reliable. It is not the alternative but the supplementary to safe driving mode and exterior mirrors.

The BSD warning lamps are located on both exterior rearview mirrors.

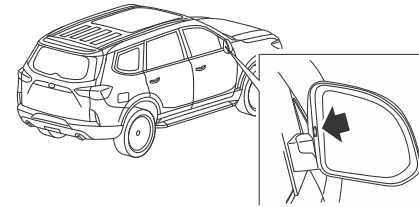

Detection areas:

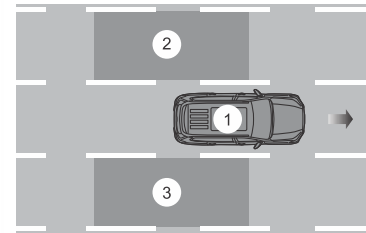

I Main vehicle

2 Left adjacent area

3 Right adjacent area

Early warning mode:

When there is a target vehicle in the left adjacent area ② or right adjacent area ③, the system will prompt the main vehicle and the warning lamp on the corresponding side will be normally on. When there is a target vehicle overtaking the main vehicle at high speed in the left adjacent area ② or right adjacent area ③, the system will prompt the main vehicle and the warning lamp on the corresponding side will be normally on.

Emergency warning mode:

When there is a target vehicle in the left adjacent area ② or right adjacent area ③, and the main vehicle is intended to change the lane (the side direction indicator lamp is on), the system will send a warning to the main vehicle and the warning lamp on the corresponding side will flash.

Note: The BSD will be enabled when the vehicle speed is above 30km/h and below 120km/h.

Note: The system provides detection only for a limited area beside the vehicle, it cannot provide sufficient warning when a rear vehicle is approaching the vehicle.

Tyres



It is very dangerous to use nonconforming or damaged tyres!

Do not drive the vehicle if you find a tyre or tyres are excessively worn, damaged or have incorrect inflating pressure.

Vehicle overload is forbidden.

Incorrect tyre inflating pressure or imbalance between wheel and tyre assembly may affect the vehicle stability severely, especially during driving under high load or at high speed. Under-inflation will increase rolling resistance, increase fuel consumption and accelerate tyre wear, resulting in tyre damage, even an accident.

Be sure to consider the situation of tyres during driving. The common causes for tyre faults include:

- Colliding with curb.
- Driving by a deep pit.
- Tyre under-inflation or pressure overload during driving.

Wheel alignment error may lead to uneven tread wear.

Tyre chain

It is recommended to mount S-shape tyre chains to driving wheels when the vehicle is about to run in snow.

Tyre chains can improve the driving traction on road in winter. If you plan to mount tyre chains, pay attention to the following points:

- 1 Not all combinations between wheels and tyres are suitable for tyre chain mounting. Make sure select approved tyre dimensions when mounting tyre chains.
- 2 Mount the tyre chains to the driving wheels. Please comply with the mounting instructions provided by the tyre chain manufacturer.

Drive at the maximum speed allowed by the tyre chains used only when the vehicle runs in snow. Please comply with the regulatory requirements of the resident country. Remove tyre chains immediately after the vehicle runs back to the road free of snow.

Loading

In accordance with regulations, each driver is obliged to ensure his vehicle is free of overload.

Note: The maximum allowed total mass is indicated on the vehicle identification plate which is located in the lower front of right B-pillar. This manual introduces correct complete vehicle mass parameters. Please refer to “Complete Vehicle Mass Parameters” in General Technical Parameters section.

Note: Fix all goods in the vehicle to prevent them from moving and accordingly causing personal injuries. The driver is obliged to ensure all goods have been fixed correctly.

In accordance with legal provisions, a vehicle carrying certain kind of dangerous good shall be marked with a specific warning sign outside.

STARTING AND DRIVING

Luggage compartment

Luggage compartment binding rings

Use the binding rings when it is required to secure and protect the objects on the luggage compartment floor. Make sure that the binding ring is not overloaded. Please withdraw the binding rings when they are not in use.

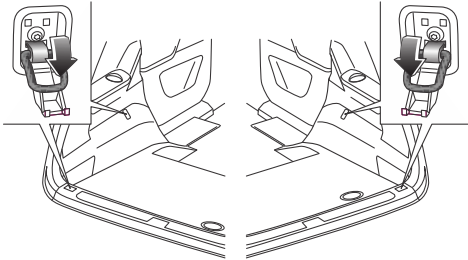

Hooks

There is a hook at both sides of the cargo area respectively. The hook is used to hold light loads.

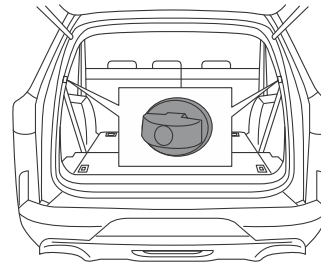

STARTING AND DRIVING

Luggage compartment cover curtain

! Do not place the luggage on the cover curtain, otherwise the cover curtain may be damaged.

Cover Curtain Usage

1 Firstly, take the luggage compartment cover curtain out of the luggage compartment. Take up (1) from the right end with your right hand, then take out in parallel with (2) shown in the figure.

Note: When using the cover curtain, the rear seats must be folded first for some models.

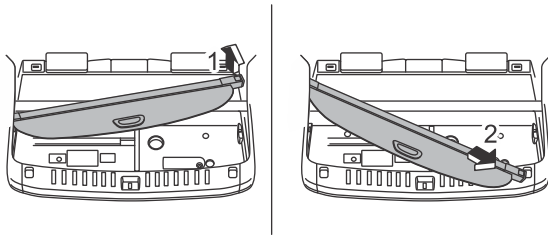

- 2 Press the button at both sides of the cover curtain to extend the cover curtain arm.

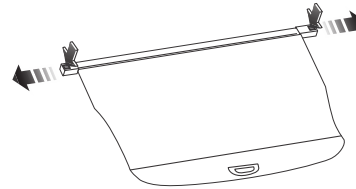

- 3 Fit both sides of cover curtain arm into the mounting holes on the rear side panel.

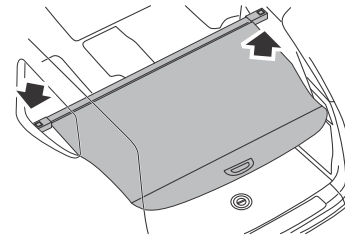

- 4 Pull out the rear side of the curtain, and then snap the mounting flange into the guide grooves on both sides of the rear opening.

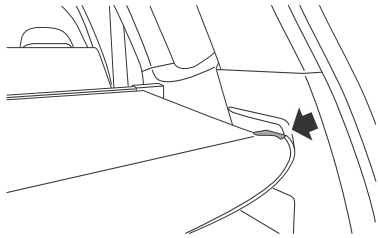

Cover Curtain Retraction

- 1 Shrink the support arms at the two sides of the cover curtain.
- 2 Put the left side of cover curtain into the left side of bin.
- 3 Make the end cap stuck in the slot of bin while pushing the end cap to the left.

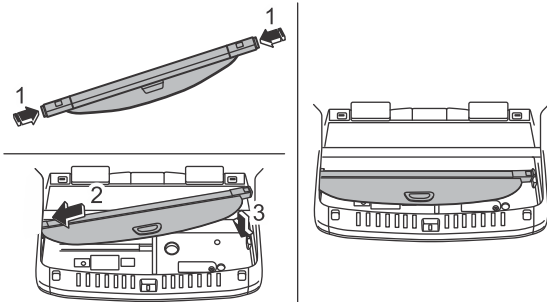

Roof Rack and Load Carrier

! Be sure to properly place the luggage on the roof rack, otherwise it may lead to an accident. Under no circumstance should the maximum roof load, maximum axle load or maximum total vehicle load be exceeded, otherwise it may lead to an accident. The roof rack with luggage carried will reduce the stability of the vehicle, especially when turning and experiencing crosswind. When heavy or bulky luggages are placed on the roof rack, the shift of the center of gravity and wind resistance may affect the vehicle handling and lead to an accident. In this case, you should adjust your driving style and speed according to the actual situations. It is not recommended to take an off-road driving when the roof rack is carried with luggages. The roof rack can only be used when the sunroof is closed, otherwise the roof rack or the luggages placed on it may endanger the surrounding person.

Vehicle handling may be affected by the carried luggages. Only install the roof rack system designed for your vehicle use. Please consult our service dealer for more information.

Make sure that the roof rack system is not overloaded. For the certified roof rack system, its own weight is not included in the load capacity.

STARTING AND DRIVING

If other roof rack system is used, its own weight must be included in the load capacity.

The load must be evenly distributed, and cannot be left unsupported on the roof rack. After travelling 50 km, check if the roof rack and load are still firmly connected.

EMERGENCY TROUBLESHOOTING

- 184 Hazard Warning Lamps
- 184 Warning Triangle
- 185 Wheel Replacement
- 190 Vehicle Towing
- 192 Fuel Filter Water Drain
- 193 Jump Start
- 195 Fuse Replacement
- 202 Bulb Replacement

Hazard Warning Lamps

When you need to stop or slow down the vehicle in case of a vehicle failure, always press the hazard warning lamp switch  on the instrument panel. The "Direction Indicator (green)" on the instrument cluster flashes, and all the turning signal lamps shall flash at the meantime to warn other road users as well as let the police know that you are in trouble.

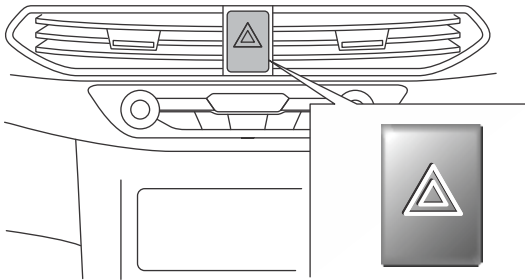

Warning Triangle

The warning triangle is placed at the bottom of the luggage compartment (for vehicles with three rows of seats) or behind the second row of seats (for vehicles with two rows of seats).

If you have to stop your vehicle on the roadside in case of a vehicle failure, you must place a warning triangle approximately 100 meters behind your vehicle to warn the oncoming vehicles.

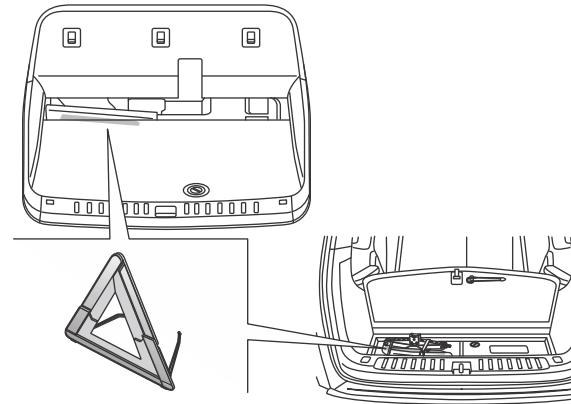

Wheel Replacement

Jack

Placement

The jack is placed at the bottom of the luggage compartment (for vehicles with three rows of seats) or behind the second row of seats (for vehicles with two rows of seats).

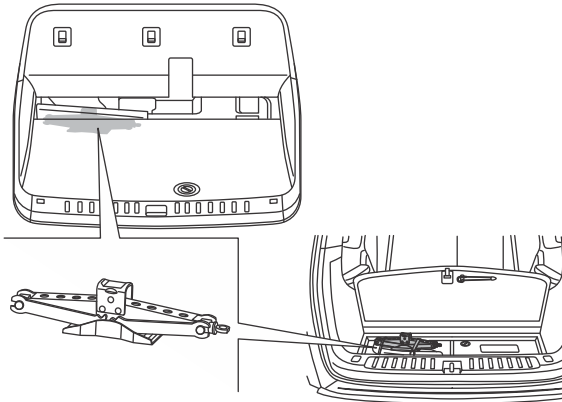

Specification



This jack is for tyre replacement only. Do not use it for other purposes. This jack is for your vehicle model only and thus should not be used for other models.

Spare wheel



Regularly check the air pressure of spare wheel. The use of a spare wheel with incorrect tyre pressure will affect wheel stability, which may lead to dangerous consequences and will cause permanent damage to the tyre.

The spare wheel is mounted at the rear bottom of the body; the wheel nut wrench and jack auxiliary rotary post in the vehicle tool kit can be used to rotate the pillar bolt of drive mechanism, thus releasing or tightening the rope for the spare wheel to achieve the function of spare wheel replacement.

Caution

After replacing with the small size spare tyre, the vehicle speed shall not exceed 120 km/h, or the risk of accident may occur. Avoid wide open throttle acceleration, hard braking and sharp turn as much as possible. It is better replace the small size spare tyre with the full size tyre as soon as possible, thus to extend the service life of the spare tyre and keep it in good state.

Spare wheel removal

- 1 Take out the vehicle tool.
- 2 Fold the seat back of third-row seats (if available) forward.
- 3 Mount the auxiliary rotary post and the wheel nut wrench.

EMERGENCY TROUBLESHOOTING

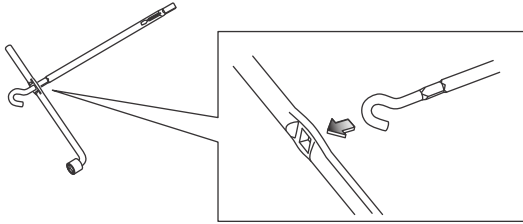

- 4 Unscrew the spare wheel rotary cap.

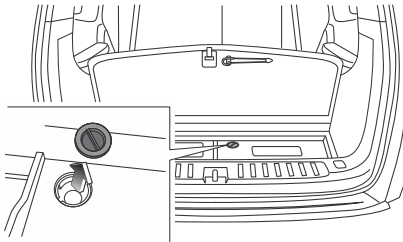

- 5 Insert the rotary post into the spare wheel loading/unloading hole through the rotary cap hole, rotate the wheel nut wrench counterclockwise to lower the spare wheel until it reaches the ground.

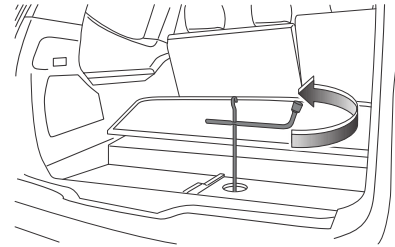

- 6 After the spare wheel reaches the ground, rotate the wheel nut wrench counterclockwise continuously and pull out the spare wheel. Excessive rotation of the wrench is prohibited, or the spare wheel device will be damaged.
- 7 Remove the tray from the spare wheel.

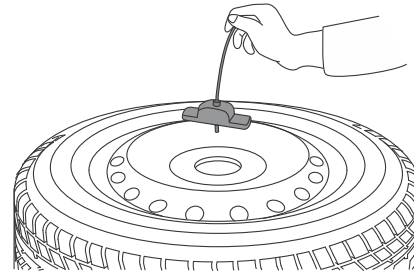

Spare wheel storage

- 1 Place the wheel on the ground with the air valve facing up (be careful not to place it reversely).
- 2 Place the wheel at the rear bottom of the vehicle.
- 3 Place the spare wheel tray in the rim center, and then adjust the tray to a proper position to allow it to be tightly connected with the spare wheel.
- 4 Rotate the wheel nut wrench clockwise until a click is heard, and the spare wheel is loaded in place.

Caution

After placing the wheel on the spare wheel holder, check whether the wheel mounting is tight. If the wheel is loose, it may fall off owing to vibration and cause an accident.

- 5 Screw the spare wheel rotary cap, and close the luggage compartment rear lid.

Wheel replacement

Vehicle parking



Please choose a solid and flat place to park the vehicle, where will neither hinder the traffic, nor throw you into a traffic accident. If your vehicle is parked on a public road, please turn on the hazard warning lamp and place a warning triangle.

Make sure that the ground where the jack is located is solid enough to support the jack and the vehicle to be lifted, or the jack may become unstable and move, thus damaging the vehicle and/or causing personal injury. Please use appropriate wheel wedges to hold other wheels.

If your vehicle is parked on a slippery place, please do not use the jack. If the conditions are not suitable for use of the jack, or you are lack of confidence to complete the task in a safe manner, please call for help. Make sure the front wheels point straight ahead.

When the engine is turned off, pull up the parking brake handle, if your vehicle is equipped with electronic parking brake system, pull up the electronic parking brake (EPB) switch to activate the electronic parking brake system, and move the shift lever to P gear.

EMERGENCY TROUBLESHOOTING

Jack placement

! The jack should be used on level firm ground wherever possible. It is recommended that the wheels of the vehicle be chocked.

No person should remain in a vehicle that is being jacked. **WARNING:** do not get under a vehicle that is supported by a jack. No person should place any portion of their body under a vehicle that is supported by a jack.

Use the jack at the specified jack point only. The height jacked up should not exceed that required by wheel replacement (for example, it should not be 30cm higher than the ground).

Before using the jack, please make sure that all occupants have left the vehicle. When the vehicle is jacked up, do not allow any person to stretch any part of his/her body under the vehicle.

During the lifting, the jack should be perpendicular to the vehicle body.

Keep the jack clean and well lubricated reapply grease every 3 months.

The jack points for front wheels are located on lower plane of longitudinal member (between the 4th cross member and the 2nd suspension). The jack points for rear wheels are located on the bracket

of horizontal stabilizer bar, and the concave of the jack should be aligned with the camber of the horizontal stabilizer bar bracket.

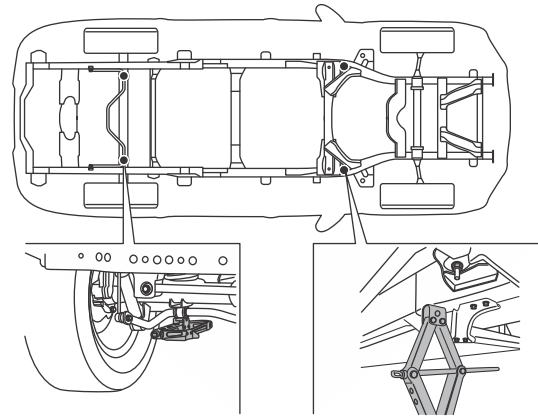

Spare wheel replacement



During the lifting, do not start the engine. Do not stand under the lifted vehicle.

Before removing the wheel nut, make sure the vehicle is stable and will not slide or move.

It is required to use a torque wrench to accurately check the tightening torque of wheel nuts, and check the tyre pressure as soon as possible after replacing the wheel.

Be sure to put the replaced wheel, jack and vehicle tool kit in the specified position. If they are placed randomly or improperly, they may move in the event of impact or emergency brake, thus causing damage or personal injury.

- 1 Remove the spare wheel, refer to "Spare Wheel" in this section.
- 2 Check whether the jack is still perpendicular to the jack point; change the position as necessary.
- 3 Use the wheel nut wrench in the vehicle tool kit to loosen the wheel nut counterclockwise.

- 4 Mount the auxiliary rotary post and then rotate the wheel nut wrench clockwise till the wheel to be replaced gets off the ground .

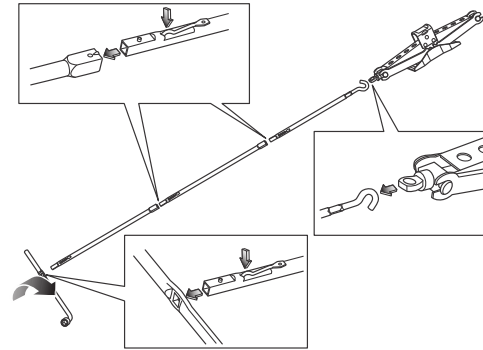

- 5 Remove the securing nuts of the wheel and then carefully remove the wheel.
- 6 Replace it with the spare wheel and then tighten the wheel nuts clockwise.
- 7 Lower the vehicle and remove the jack.
- 8 Fully tighten the securing nuts of the wheel in a diagonal order (see the diagram); the wheel nut torque is $125 \pm 13 \text{ Nm}$.
- 9 The replaced wheel shall be loaded in the position of spare wheel, please refer to "Spare Wheel Storage" in this section.

EMERGENCY TROUBLESHOOTING

- 10 Put away the replaced wheel, auxiliary rotary post of the jack, wheel nut wrench, jack and vehicle tool kit.

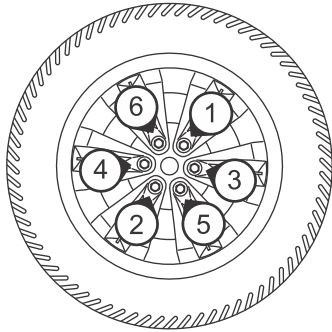

Caution

Be sure to fully lift and tighten the tray of the spare wheel device even if no spare wheel is mounted.

Vehicle Towing

When towing a vehicle or making a vehicle be towed, be sure to observe relevant national regulations on vehicle towing.

Towing Eye

Front Towing Eye

The front towing eye is located at the lower side of front bumper.

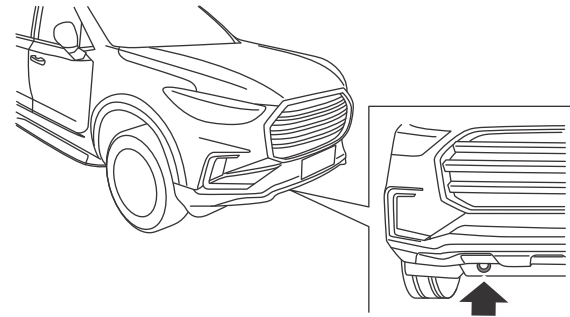

Caution

The mass that the front towing eye can bear is $1/2GVW$ (total mass). Do not tow a vehicle with a mass more than this value.

EMERGENCY TROUBLESHOOTING

Rear Towing Eye

If it is required to tow a vehicle from rear side, remove the towing eye plug from the left side of rear bumper, and screw the rear towing eye in the vehicle tool kit into the rear bumper.

After completing the vehicle towing, unscrew the rear towing eye and place it in the vehicle tool kit, and replace the towing eye plug.

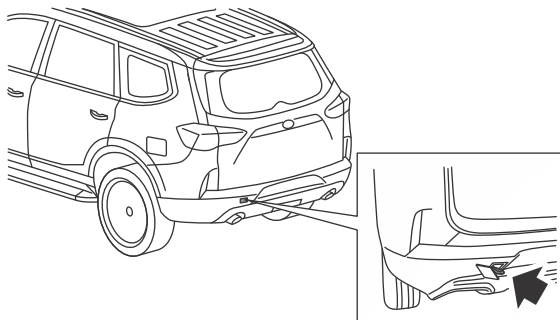

Caution

The mass that the rear towing eye can bear is $1/2$ GVW (total mass).
Do not tow a vehicle with a mass more than this value.

The application range of towing rope is as shown below:

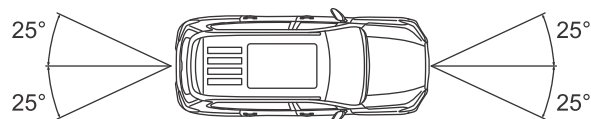

Towing

Before Being Towed



To ensure the steering gear can rotate freely, turn the ignition switch to "ON" position and keep it in this position during towing process. This is to ensure the steering is unlocked, and the steering indicator and brake lamp can operate.

While Being Towed

When the vehicle is being towed, release the parking brake and engage N gear.



When the engine is not operating, it is not assisted by brake booster and power steering. In this case, it needs to operate the brake pedal with larger force and rotate the steering wheel for longer time.

Caution

- When towing vehicles, for 2WD AT models, be sure to lift the driving wheels off the ground, and maintain the towing speed less than 50km/h. When the towing distance is less than 50km, place the shift lever in N gear.
- When towing vehicles, for 4WD models, please tow the whole vehicle with a flat bed trailer.

Fuel Filter Water Drain

Note: It applies to vehicles equipped with diesel engine.



Be sure to wear proper gloves to protect hands from touching diesel.

Drain water according to the following steps:

- 1 Turn the ignition switch to "LOCK" position.
- 2 Put a proper container under the fuel filter drain bolt and unscrew the drain bolt (1) with a proper tool.
- 3 Drain till clean diesel appears, then re-tighten the drain bolt (1) to 2~2.5 N.m.
- 4 Start the engine. "Fuel filter water level warning lamp (yellow)" shall go out in 2 seconds. Check the filter for fuel leakage.

Caution

If "fuel filter water level warning lamp" on the instrument cluster illuminates during driving, please park the vehicle in a safe place, shut down the engine and drain water.



Do not pour diesel fuel into domestic or public sewage system. Please use locally approved waste treatment equipment.

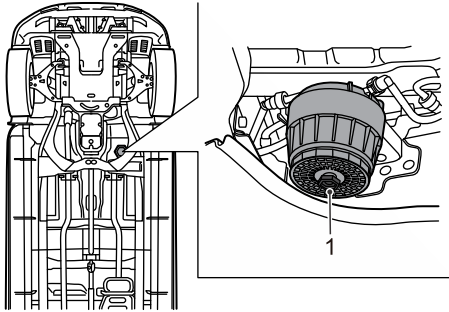

Jump Start

Battery Disconnection

! Wear protective gloves and goggles during the operations related to battery.

Do not use open fires, generate sparks or smoke in the battery area. Or you will be injured and the vehicle will be damaged.

To disconnect the battery, be sure to disconnect the negative (-) grounding terminal first and then the positive (+) one. When connecting the battery, please install and tighten positive cable (+) first and then negative (-) cable. And cover the terminals with Vaseline.

3

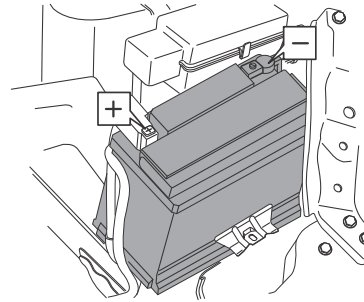

EMERGENCY TROUBLESHOOTING

Caution

- Before disconnecting the battery, be sure to shut down the engine and turn off all electrical appliances for more than 2 minutes. Please avoid the terminals from contacting with metal components of the body during disconnection. The resulted short circuit may generate electric sparks.
- Reverse connection of positive and negative cables will cause damage to electrical system.

Jump Start



It is never allowed to start the vehicle by pushing or towing.

Make sure that both batteries are of the same rated voltage (12V), and the jumper cables are approved for use with 12V car batteries.

- 1 Make two vehicle and battery jumper close enough.
- 2 Shut down the engine and turn off all electrical equipment.
- 3 Connect the positive terminals(+) of both batteries with a red jumper cable.
- 4 Connect a black jumper cable between the negative terminal (-) of power supply battery and the grounding point (not negative terminal) of the battery to be charged.
- 5 Make sure all connecting devices contact well.
- 6 Check whether jumper cables contact with any moving parts when engine starts.
- 7 Check whether the parking brake handles of vehicle has been engaged and whether the shift lever is in N gear.

EMERGENCY TROUBLESHOOTING

Starting

Start the vehicle with power supply battery and allow it idle for several minutes.

- 1 Start the vehicle with battery to be charged.
- 2 Allow the engine idle for 2 minutes and above after it is started.
3. Once the car is started drive for more than 100 kms. to make sure battery gets some charge. (It does not guarantee further discharge)

Note: If it fails to start after several attempts, the vehicle probably needs service.

Disconnection

- 1 Shut down the engine of the donor vehicle.
- 2 Make sure the wire terminals will not contact with each other and will not contact any moving parts of engine during disconnection.
- 3 Remove the jumper cables. Removal is the reverse of connection.

Fuse Replacement

Fuses of this vehicle are respectively placed in two boxes.

Caution

Any electrical components of the vehicle will be damaged after being splashed with fluid. Be sure to cover any electrical components. The contents in the fuse specification list are subject to continuous modification according to vehicle configuration and technical state. Please follow the list based on actual condition of your vehicle.

Driver Compartment Fuse Box

Driver compartment fuse box is located behind the lower storage box at driver side.

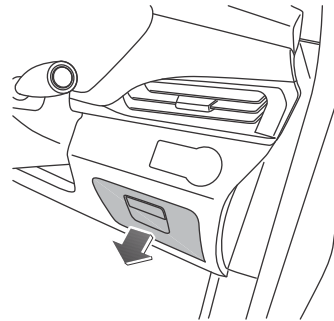

EMERGENCY TROUBLESHOOTING

Fuses in the driver compartment fuse box can be identified by the label on the back of lower storage box cover at driver side.

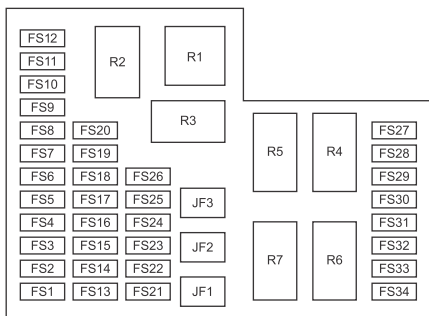

Specifications of Driver Compartment Fuse

Fuse	Specification	Function
FS1	15A	Heated steering wheel
FS2	10A	IG power: IMMO base station/instrument cluster/body control module
FS3	10A	IG Power : supply airbag control module
FS4	15A	PEPS controller
FS5	10A	IG power: auto anti-dazzle rearview mirror/LDWS/LKA
FS6	10A	IG power: front A/C panel/EPB switch/rearview mirror adjusting switch
FS7	7.5A	Lane departure aid
FS8	25A	Front sunroof/Sunshade
FS9	25A	Passenger's side power seat
FS10	25A	Driver's side power seat

Fuse	Specification	Function
FS11	15A	ACC4
FS12	10A	Active noise control
FS13	10A	TBOX/12-inch display screen
FS14	10A/15A	Ignition switch/(PEPS ECU/kick sensor)
FS15	10A	Front blower feedback
FS16	10A	Rear blower feedback
FS17	10A	ACC2
FS18	10A	ACC3
FS19	15A	ACC1
FS20	30A	Power amplifier
FS21	10A	Instrument cluster
FS22	15A	Automatic transmission
FS23	25A	MP5/Radio
FS24	10A	Diagnosis Interface
FS25	10A	Front A/C control panel/lumbar/driving mode switch/trunk lamp/ambient lamp/air purifier
FS26	/	Reserved
FS27	/	Reserved
FS28	/	Reserved
FS29	25A	Driver's side power window lifter
FS30	25A	Passenger's side power window lifter
FS31	/	Reserved
FS32	/	Reserved
FS33	/	Reserved
FS34	10A	Rear view mirror heating
JF1	30A	Digital fan
JF2	40A	Power seat
JF3	30A	Panoramic sunroof
R1	/	Front blower relay
R2	/	ACC relay

EMERGENCY TROUBLESHOOTING

Fuse	Specification	Function
R3	/	IG relay
R4	/	Trunk light relay
R5	/	Rear view mirror/Rear window heating relay
R6	/	Digital fan relay
R7	/	Puddle lamp relay

Front Compartment Fuse Box

The front compartment fuse box is located at the right of compartment wall at the front hood bottom and behind the right headlamp (viewed from the front of vehicle).

Type I

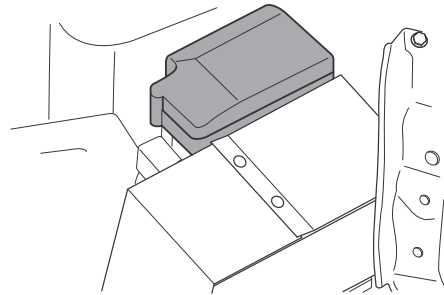

EMERGENCY TROUBLESHOOTING

Specifications of Front Compartment Fuse

Type I

Fuse	Specification	Function
FS1	10A	KL30 PWR
FS2	25A	Heated rear window/rearview mirror/cargo lamp
FS3	30A	IEC power supply 5
FS4	25A	Fuel pump
FS5	25A	ABS/ESP_valve
FS6	15A	Engine control module
FS7	30A	Front wiper
FS8	15A	SCR relay power
FS9	15A	A/C compressor/battery sensor
FS10	30A	IEC power supply 3
FS11	25A	Fog lamp/position lamp/daytime running lamp
FS12	25A	IEC power supply 8
FS13	25A	Low beam
FS14	20A	High beam
FS15	30A	IEC power supply 2
FS16	30A	BCM KL30
FS17	/	Reserved
FS18	20A	Nitrogen oxygen sensor/PM sensor
FS19	15A	WCAC Coolant pump
FS20	15A	Engine harness inline supply
FS21	15A	Main relay power supply
FS22	20A	Horn
FS23	I	Reserved
FS24	10A	Rear fog lamp/position lamp/daytime running lamp
FS25	10A	Rearview mirror folding/taillgate/fuel tank cap

Fuse	Specification	Function
FS26	25A	Central lock
FS27	10A	BCM_interior lamp/vanity/mirror/rain light sensor
FS28	15A	Left high beam
FS29	15A	Right high beam
FS30	15A	Left low beam
FS31	15A	Right low beam
FS32	10A	Headlamp leveling
FS33	25A	Exterior lamps
FS34	15A	Washer/rear wiper
JF1	30A	Main relay
JF2	50A	Electronic parking
JF3	30A	Starter
JF4	30A	IG power supply
JF5	60A	ACC power supply
JF6	40A	IEC power supply 9
JF7	40A	DC stabilizer 2
JF8	40A	ABS/ESP_motor
JF9	40A	Front blower
JF10	40A	Rear blower
JF11	60A	IEC power supply 1
JF12	60A	IEC power supply 6
MIDI	100A	Cooling fan
PR1	I	PTC1 relay
PR2	I	PTC2 relay
R1	I	SCR relay
R2	I	PTC3 relay
R3	I	Horn relay
R4	I	Starter relay

EMERGENCY TROUBLESHOOTING

Fuse	Specification	Function
R5	/	Fuel pump relay
R6	/	Wiper power relay
R7	/	Wiper speed relay
R8	/	Main relay
R9	/	A/C compressor relay
R10	/	Rear fog lamp relay
R11	/	Position lamp relay
R12	/	Left front fog lamp relay
R13	/	Right front fog lamp relay
R14	/	Low beam lamp relay
R15	/	High beam lamp relay
R16	/	Left daytime running lamp relay
R17	/	Right daytime running lamp relay

Type II

Fuse	Specification	Function
FS1	20A	Inverter
FS2	10A	Gateway
FS3	10A	Differential lock controller
FS4	25A	Left rear power window
FS5	10A	Tyre pressure monitoring/360 BSV
FS6	15A	Front seat heating
FS7	15A	Rear seat heating
FS8	30A	TCCU power supply 1
FS9	30A	TCCU power supply 2
FS10	25A	Right rear power window
FS11	30A	ACC 1
FS12	10A	ACC 2
FS13	10A	IG power supply 1

Fuse	Specification	Function
FS14	10A	IG power supply 2
FS15	10A	IG power supply 3
FS16	10A	IG power supply 4
FS17	15A	Front axle clutch
FS18	30A	Diesel filter relay power
JF1	60A	GCU
JF2	40A	HCU
JF3	40A	PTC1
JF4	25A	Power liftgate controller
JF5	40A	PTC2
	40A	PTC3
R1	/	ACC relay
R2	/	Diesel filter relay
R3	/	Rear blower relay
R4	/	IG relay

Fuse Replacement

! Replace only with the fuse of identical specification or rated current. Installation of non-specified fuse will cause damages to electrical system and even cause fire. Turn off the ignition switch and power off all electrical equipment before replacing the fuse. Any unauthorized change to electrical system of the vehicle will cause serious adverse effects to electrical management system and cause fire.

Pull out the fuse with a puller provided in the fuse box to remove the fuse. Determine whether the fuse is blown according to wires inside the fuse (as indicated by the arrow).

Note: *Repeated failure with the same fuse is the indication of circuit failure. Please contact our Service Dealer as soon as possible.*

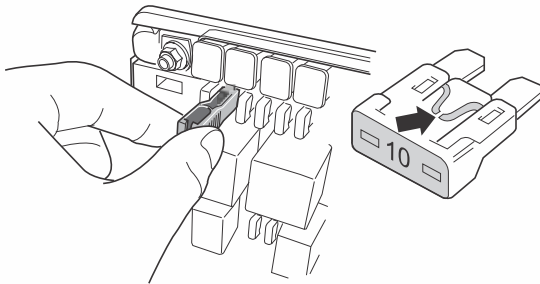

Caution

Unauthorized change to electrical system of the vehicle will invalidate the warranty .

Bulb Replacement

Before replacing any bulb, turn off the ignition switch and lighting switches to avoid any possible short circuit. When removing or installing the bulb, do not touch the bulb with hands. If touched, wipe away the hand print with a piece of cloth or alcohol.

Caution

The bulb replacement must be identical with the original one in type and specification.

Bulb Specification

Bulb	Specification
Low/high beam	HIR2
Front turning signal lamp	PY21W
Front fog lamp	H11
Rear turning signal lamp (type I)	PY21W
Reverse lamp (type I)	W21W
Brake lamp/rear width lamp (type I)	P21/5W
Rear turning signal lamp (type II)	WY21W
Reverse lamp (type II)	W21W
License plate lamp	W5W
Front ceiling reading lamp	W5W
Rear ceiling reading lamp	W5W

MAINTENANCE AND SERVICE

- 204 Safety
- 205 Regular Maintenance
- 205 Owner Checks
- 206 Front Compartment
- 207 Engine Hood
- 208 Engine Oil
- 210 Coolant
- 212 Brake Fluid
- 213 Washer Fluid
- 214 Washer Nozzles
- 214 Wiper Blade
- 215 Seat Belt
- 216 Battery
- 220 Tyres
- 222 Other Maintenance

Safety

During vehicle inspection or maintenance, take care to reduce risks of personal injury or vehicle damage, and always observe the following safety precautions:



Turn off the ignition switch, unless otherwise specified in special procedures.

When the engine is running, be sure to keep hands, tools and clothes away from drive belt and belt pulley.

Radiator fan may start at any time (even when the engine is not running). Always ensure your hands, loose clothing (such as ties, scarves, etc.) stay away from fan blades.

After the engine is starting/running, many components under the engine hood will be hot, such as engine, exhaust system, cooling system and power steering fluid reservoir, etc. Do not touch until it is cooled down.

Do not touch wires or components with the ignition switch in "ON" position. Keep in mind that the batteries and wires carry with high current or voltage possibly causing personal injury. Avoid short circuit.

Do not start the engine in unventilated place as poisonous gases exhausted is very dangerous.

If possible, operate the engine compartment after engine shut-down and battery disconnection (refer to

"Jump Start" in Emergency Troubleshooting section). If components under the engine hood shall be inspected when the engine is running, make sure the vehicle is on a level ground, the parking brake handle has been pulled up and the shift lever is in N or P position. Keep match and open fire away from the battery area and all fuel related components. Do not smoke near these areas and components.

Most fluid used for motor vehicles are toxic. Do not drink or contact with skin or eye. These fluid include battery acid, coolant, brake fluid, power steering fluid, fuel, detergent, lubricating oil, refrigerant, etc. Please wear protective gloves to refill the fluid. And observe all instructions on labels and containers. When operating on or under the vehicle, wear protective glasses if it is possible to touch splashed or fallen articles and sprayed fluid.

Long-term contact with engine oil may cause skin diseases, including dermatitis and skin cancer. Clean it thoroughly after contact.

Be sure to keep children and pets away from the vehicle. Nobody is allowed to stay in the vehicle (except those work in the vehicle according to your instruction). Be sure to keep children away from oil, fluid and lubricating grease.

Regular Maintenance

Regular maintenance of the vehicle will be beneficial to the economy, safety and reliability of your vehicle. It is important to remember that the responsibility for ensuring vehicle safety and suitable for road travel is ultimately your own (owner / operator).

Specify the maintenance required and interval for it to maintain your vehicle properly. Please go to Service Dealer for regular maintenance of the vehicle in accordance with the provisions in the "Warranty and Maintenance Manual".

Regular maintenance of your vehicle in accordance with the requirements will ensure your best interests.

Our Service Dealer has qualified personnel, required equipment and pre-established maintenance plan, which can provide the most reliable service for the vehicle. Therefore, it is recommended to carry out regular maintenance at our Service Dealer.

Owner Checks

To ensure the reliability and economy of driving, the vehicle owner must carry out the following simple but important checks:

Daily Check

- The function of lighting (make sure all lens are clean), horn, instrument cluster, warning lamps and indicator lamps, wipers and washers.
- Whether the seat belt is intact.
- Whether the brakes operate normally.
- Visually check if there is water, oil, fuel, exhaust fume and other leakage under the vehicle.

Weekly check or check before a long trip

- Check fluid level / refill.
 - Engine Oil
 - Coolant
 - Windshield Washer Fluid
 - Power steering fluid
 - Brake fluid
- Check the condition and pressure of all tyres (including spare wheel).
- Check and operate air conditioning system.

Severe Working Conditions

It is advised to shorten the maintenance interval if the vehicle is used in severe working conditions frequently.

Please go to Service Dealer for regular maintenance of the vehicle in accordance with the provisions in the "Warranty and Maintenance Manual".

Front Compartment

Type I

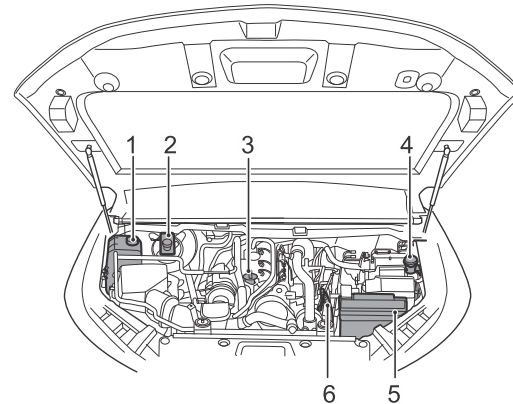

- 1 Engine coolant reservoir
- 2 Brake fluid reservoir
- 3 Oil fill cap
- 4 Washer fluid reservoir
- 5 Battery
- 6 Oil dipstick

Type 2

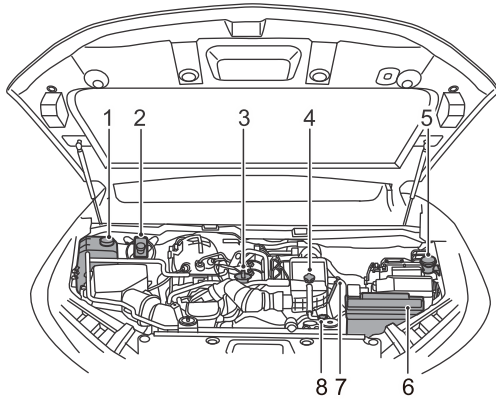

- 1 Engine coolant reservoir
- 2 Brake fluid reservoir
- 3 Oil fill cap
- 4 Water-air intercooler pressure cap
- 5 Washer fluid reservoir
- 6 Battery
- 7 Oil dipstick
- 8 Water-air intercooler coolant reservoir cap

Engine Hood

Open the Engine Hood

Pneumatic Rod

- 1 Pull the engine hood release lever below the splash guard at driver side to unlock the engine hood.

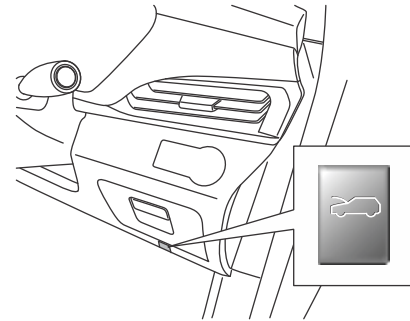

- 2 Slightly raise the front part of the engine hood, push the lever to the right and lift the engine hood.

Close the Engine Hood

 **When the ignition switch is in "ON" position, the radiator fan may start at any time (even if the engine is not running). Always ensure your hands, loose clothing (such as ties, scarves, etc.) stay away from fan blades.**

If the engine is running, keep your hands, clothing, etc. away from the rotating pulley, drive belt, fan blades and other devices.

Pneumatic Rod

Press down on the front part of the engine hood until you hear the sound which indicate the latch is snapped. Try pulling the engine hood up to check if the locking mechanism is properly snapped.

Caution

Before closing, check if there is any tool, cloth, equipment or etc. left in the area under the engine hood.

Engine Oil

It is recommended to use the oil of correct grade, please refer to "Recommended Fluids" in the General Technical Parameters section for the specifications.

Our authorized dealers are willing to provide you with the latest changes and improvements on the recommended oil. If the emperature in your area is extremely low (below -30°C), it is recommended to use special oil for winter use in your engine. Please contact our authorized dealers for details.

Caution

Do Not use oil that does not meet the requirements of the specified grade. Improper use of the oil can cause damage to the engine and void warranty.

Check and Refill



Do not exceed the maximum mark when refilling.

Long-term frequent exposure to used engine oil can cause severe skin disease. Please avoid excessive skin contact with engine oil, in case of contact, rinse your skin thoroughly.

Keep the engine oil out of the reach of children and pets.

Be sure to check the oil level or refill the oil when the vehicle is parked on a flat ground and the engine is not running (in cold state). If the engine is hot, turn off the ignition switch and wait for 2 minutes before checking.

Pull out the oil dipstick and wipe the blade with a paper or lint-free cloth. Completely insert the oil dipstick back and then pull out.

The oil level indication must be between "MAX" and "MIN".



Caution

Check the engine oil level frequently, and refill as necessary. Both excessive and insufficient refilling of engine oil is likely to damage the engine, and the damage are not covered by warranty.

If you need to refill, please unscrew the oil filler cap, then add new oil of correct specification in several times and in small quantities. Repeat the oil level check process after the oil drops into the tank. Refill as necessary until the oil level is correct.



Empty containers and used oil can not be discarded randomly, so as to avoid environment pollution.

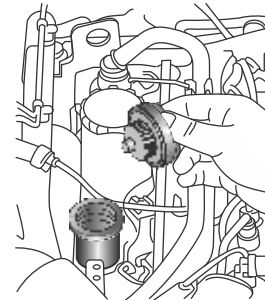

Engine Oil Consumption

The engine oil consumption is affected by a variety of factors (these factors also affect fuel consumption), of which the oil type and driving pattern (especially in the "running-in" period) are the two most important factors. Generally, the engine oil consumption is higher in the "running-in" period and in continuous high-speed operation. You must follow the suggestions on driving tips in this manual. Please refer to "Driving" in Starting and Driving section.

Coolant



The coolant is harmful, Don't swallow It. Do not allow coolant come into contact with your skin and eyes. In case of contact, rinse with plenty of clean water immediately .

The coolant of correct specification can not only protect the engine from frozen damage , but also offer corrosion protection throughout the year. If coolant of correct specification is not added, do not drive the vehicle. Refer to "Recommended Fluid" in the General Technical Parameters section for the coolant specification.

The fluid in the cooling system must be discharged at a specified interval, then the system shall be rinsed, and the appropriate amount of coolant should be refilled.

Caution

Only use the specified coolant for filling or replacing. If a non-recommended coolant is used, the cooling system may be damaged and the warranty may become invalid.

Check and Refill



Do not remove the expansion tank cap while the system is hot, for escaped water vapor or hot coolant may cause injury. If you have to add coolant when the engine is hot, please wait for 10 minutes, cover a thick cloth on the expansion tank cap, slowly rotate the coolant reservoir cap counterclockwise to release the pressure inside the coolant reservoir, and then remove the reservoir cap.

Be sure to check the coolant level when the vehicle is parked on a flat ground and the engine is not running (in cold state).

The fluid level is visible on the expansion tank, and the normal level should be between the "MAX" (the maximum amount) and "MIN" (the minimum amount) marks.

If the level drops to the "MIN" mark, clean the area around the coolant reservoir cap and rotate the reservoir cap counterclockwise to remove it. Refill the specified coolant to the level between "MAX" (the maximum amount) and "MIN" (the minimum amount). Replace the reservoir cap.

Note: The coolant may expand which it becomes hot, so the liquid level may be higher than the level mark.

Note: Excessive refill may cause the coolant overflow when the engine temperature rises, which undermines the cooling effect. Simply refill the fluid to the indicated level when the engine is cool.

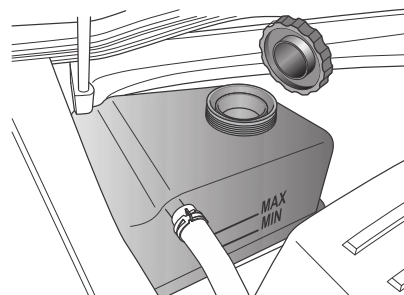

Caution

If the fluid level drops significantly or frequent refilling is required, consider if leakage or overheat conditions exist. If so, contact our Service Dealer for service as soon as possible.

Precautions in cold weather

To reduce the possible problems caused by the use of coolant in cold weather, the following recommendations should be taken into consideration:

- The standard freezing point of coolant used in the vehicle is -35°C (the mixture ratio of coolant and water is 1:1), therefore it is required to park the vehicle in an area that can maintain the coolant temperature above -35°C .
- When the vehicle is used in an extremely cold area where the temperature is lower than -35°C , a suitable proportion of coolant based on the local temperature is recommended. (Refractometer T10007 can be used to detect the freezing point of coolant).

Brake Fluid



If the brake fluid level drops obviously, contact Service Dealer for service as soon as possible.

Only new brake fluid of specified type can be used. Using brake fluid which is used or of non-specified type may impair the brake performance.

It is crucial to keep the brake fluid clean. If any dust enters in the system, it may result in brake performance decline.

Don't allow brake fluid to contact your skin and eyes, in case of contact, rinse with plenty of water. Keep the brake fluid out of the reach of children.

Do not allow brake fluid flowing onto the engine, otherwise it may be ignited when the engine heats up, causing a fire and damage to the engine.

Note: Fluid used by the hydraulic clutch also comes from the brake fluid reservoir.

Caution

- Only the brake fluid that conforms to the DOT4 specification can be filled in the master cylinder of the brake. Do not use brake fluid of other types.
- If the brake fluid contacts the paint, it will cause damage to the paint. Wipe clean immediately and rinse with clean water.

Check and Refill

Be sure to check the brake fluid level after the vehicle is parked on a flat ground and the system is in cold state. The brake fluid level is visible on the reservoir, and the normal level should be between the "MAX" (the maximum amount) and "MIN" (the minimum amount) marks. If the level drops to the "MIN" mark, clean the area around the fluid refill cap and rotate the reservoir cap counterclockwise to remove it. Refill the specified new brake fluid to the level between "MAX" and "MIN", then replace the reservoir cap.

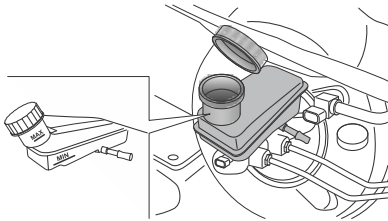

If the level is lower than the "MIN" mark, "Brake System Warning Lamp (red)" on the screen of information center will illuminate. It indicates that the brake system is malfunctioning. Figure out the reason immediately. If you are driving, stop the vehicle carefully and immediately. Please contact our Service Dealer for service as soon as possible. Do not continue to drive.



Do not discard the used brake fluid randomly, so as to avoid environment pollution.

Washer Fluid

Check and Refill



It is dangerous to drive the vehicle while the washer system is inoperative, be sure to check the system before driving.

The windshield washer fluid reservoir is located in the engine compartment. When refilling is needed, please lift the front part of the refilling cap to add the washer fluid, and then close the cap. Refer to "Recommended Fluid" in the General Technical Parameters section for washer fluid specifications.

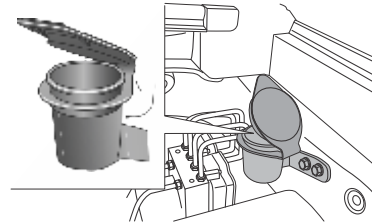

Caution

Don't use unqualified washer fluid. Don't use tap water since the mineral substance in tap water will block the pipe or nozzle of the windshield washer fluid.

Washer Nozzles

Adjust and Clean

Front Washer Nozzle

Front washer nozzle is not adjustable.

Make sure that the washer reservoir contains washer fluid before cleaning the nozzle. If the nozzle is blocked, carefully clean it with a fine line or needle.

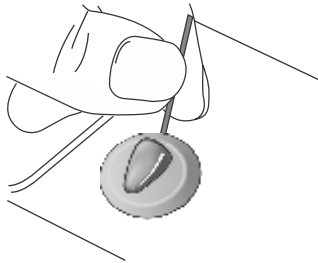

Rear Washer Nozzle

Rear washer nozzle is not adjustable.

Wiper Blade

Check

Check the edge of wiper blades for roughness or damage, and check if the blade rubber is secure from top to bottom.

Note: If there are grease or other impurities on the rubber blades, it may cause the wiper work improperly and may damage the windshield.

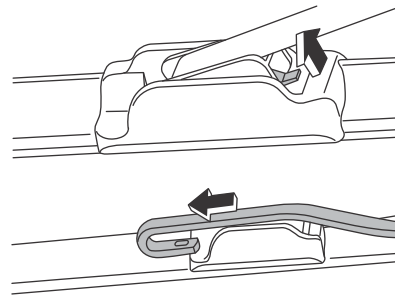

Replacement

Removal

- Lift the wiper arm from the windshield to make an angle of about 15 degrees between the blade and the arm.
- Push the retaining clip (in the direction of the arrow), slide the blade bracket along the direction of the arrow to the arm so as to loosen the pivot of the bracket from the hook of the arm.

Note: Remember the relative location of hook and bracket because the replacement blade is required to be fitted later in the same way.

Installation

- Install the blade holder on the hook.
- Snap the pivot into the hook and push it in place, until hearing an audible sound of snapping into place.

Maintenance

Wash it with high-quality or neutral detergent, and wipe with a lint-free dry soft cloth.

Seat Belt

Check



The seatbelt is equipped with a sensitive retractor, which will be locked only in hard acceleration, deceleration or drastically bend.

Don't test the locking device by fiercely and intentionally bending your upper body forward.

Check all the seat belts as shown below:

- Check all the seat belt anchor point for safety.
- Insert the locking tab into the buckle and check if the locking action is definite. Push the red button and check if the locking tab pops neatly.
- With the belt partially loose, hold the locking tab and pull it suddenly. Check if the safety device can be locked automatically and prevent further looseness.

Maintenance



Don't try to fix retractor or buckle mechanism by any means or modify the seat belt. If the seat belt has been stretched in the event of an accident, please ask Service Dealer to replace it and check the anchor point.

Check the seat belt webbing for signs of scratch or wear on a regular basis, and pay special attention to the anchor point and adjuster.

Clean the seat belt with a sponge dipped in warm water and mild soap; it can be naturally dried, and should not be directly heated or exposed to sunlight. Do not allow water penetrating into the retractor. Never bleach or dye the seat belt, as doing so may reduce its strength.

Battery

Warning notice on battery:



Wear glasses!



Wear protective gloves and glasses since battery acid is highly corrosive!



Open flames, electric sparks, strong light and smoking are prohibited!



Explosive mixed gas may be produced during battery charging!



Children should be kept away from acid and battery!



Risk of injury, corrosion, accident and fire exists when operating on vehicle battery and electrical appliance!

Wear protective glasses. Prevent acidic or lead particles from falling into eyes, on skin or clothes.

Wear protective gloves and glasses since battery acid is highly corrosive! The battery can not be turned over because the acid may flow out of the air vent. If the acid splashes into eyes, wash with clean water for a few minutes, then go to see a doctor immediately. If the acid splashes on skin or clothes, immediately neutralize it

MAINTENANCE AND SERVICE

with rich soap solution and rinse with plenty of water. If you mistakenly drink acid, go to see a doctor immediately.

Open flames, electric sparks, strong light and smoking are prohibited! Avoid sparking when handling cables and electrical equipment and removing electrostatic loads. Battery electrode must not be short-circuited because sparks with high energy pose a risk of injury.

Battery charging may produce explosive mixed gas, you must ensure that the battery air vent is open to successfully discharge the gas. The battery should be located in a well ventilated space during charging.

Children should be kept away from acid and battery.

Turn off the engine, ignition switch and all the electrical appliances before working on electrical appliances. Remove the battery negative cable. Turn off the lamp in bulb replacement.

Please pay attention to the polarity of power supply. check if the polarity of power supply matches before energizing.

Each energizing period should not be less than 5 seconds, to avoid frequent or fast on and off operation.



First remove the negative cable, then the positive one to remove the battery.

Turn off all the electrical appliances before energizing the battery again. First connect the positive cable, then the negative one. Do not connect the wrong cable- Risk of fire!

Unauthorized removal and installation of battery are prohibited, because in some cases, this operation will lead to serious damage to the battery and fuse box. Please contact Service Dealer.

Do not disconnect the battery when the ignition switch is on or the engine is running, otherwise it may damage the electrical appliances (electrical components).

To prevent the battery case from being exposed to ultraviolet light, do not expose the battery to sunlight.

Car parking period

If the vehicle is to be parked for an extended period of time, the static current electrical appliance (like clock, security devices) will drain the battery, and the battery has to be recharged. To avoid such case, charge the battery or disconnect the battery negative cable during the vehicle parking.

Note: Please pay attention to the warnings & instructions for battery before working on it.

Caution

Always turn off the ignition switch when parking, otherwise, it will greatly reduce the parking time.

Winter Operation

Vehicle battery has particularly stringent requirements in winter. In addition, the starting power provided by battery at low temperature is only part of that at room temperature. So we recommend that before the cold season comes, it is better to have vehicle battery checked at Service Dealer, and recharge it as necessary.

If the vehicle will not be in use for a few weeks in an extremely cold situation, you should remove the vehicle battery and store it in an unfrozen room so that it will not be frozen and damaged.

Battery charge with ground equipment



Don't charge the frozen battery for the risk of explosion. Even if the battery has been unfrozen, battery acid may still overflow, resulting in corrosion damage. The frozen battery must be replaced.

Turn off the ignition switch and all electrical appliances before charging.

If the vehicle has been stored for an extended period of time, and can not be started due to battery undercharge (general terminal voltages $\leq 12V$), the battery must be removed from the vehicle and charged with ground

equipment (operating in accordance with the charging device manufacturer's instructions).

When charging with a low current (such as a small charging device), generally it is not required to remove the battery connecting cables. But you must pay attention to the instructions given by the charging equipment manufacturer.

Before the quick charge, that is, before the high current charge, you must remove two connecting cables.

Note: Please pay attention to the warnings & instructions for battery before working on it. When charging, the power supply of charging device can be switched on only after the charging device electrode chuck clipped to the battery electrode as specified. After charging, first turn off the charging device, unplug the power cord, and then remove the electrode chuck of charging device from the battery.

Caution

- Keep children away from the battery, battery acid and charging devices.
- The battery can only be charged in an ventilated space. Smoking, open flame and electrical sparks are prohibited, because explosive mixed gas will be produced during battery charging!
- To protect your eyes and face, please stay away from the battery.
- If the acid splashes into eyes or on skins, rinse with clean water for a few minutes and go to see a doctor immediately.
- Battery fast charging is dangerous and should be performed by Service Dealer, because it requires specialized charging equipment and knowledge.
- Replace the frozen or unfrozen battery. Cracking may occur on the battery case because of freezing. Battery acid may leak and damage the vehicle.

Battery removal

Turn off the ignition switch and all electrical appliance before removing the battery.

To remove the battery, you should first remove the negative cable, next the positive cable, and then remove bolts on the battery retaining bracket, finally remove the battery.

Battery replacement

Battery installed on your vehicle is designed according to appropriate mounting position. If the battery is to be replaced, the new battery should have the same voltage (12V), structure form and safety mark as those of the original one. The current intensity and capacity should be in line with that of the original battery. Service Dealer can provide genuine battery.

Please note that the ignition switch and the electrical appliance have been turned off when installing the battery.



In regard of the old battery disposal, it is better to have the battery replaced by Service Dealer. In addition, the battery contains sulfuric acid and lead, so it absolutely can't be treated as household waste.

Battery installation

Turn off the ignition switch and all electrical appliance before removing the battery.

Place the battery in the mounting position and secure it with battery bracket.

Secure the positive cable then the negative one, then energize the battery.

Caution

To avoid battery discharge, please turn off the ignition switch when leaving the vehicle.

Tyres

! It is very dangerous to use nonconforming or damaged tyres! Do not drive the vehicle if you find a tyre or tyres are excessively worn, damaged or have incorrect inflating pressure.

Regularly check the tyre and its sidewall for any sign of distortion (boss), cut or wear. Remove gravel and other sharp objects with an appropriate blunt. They may pierce tyres if you ignoring them.

Tyre Pressures

! If you drive the vehicle in the case of wrong tyre inflation, it may affect the stability of the vehicle, increase the rolling resistance, result in accelerated tyre wear, and may permanently damage the tyre layer.

Remember the provisions on tyre wear and inflation. The driver is responsible for ensuring that tyres conform to these requirements.

Please check the tyre pressure (including spare tyre) every week and adjust the tyre pressure as necessary according to the "tyre pressure mark" on the front side door frame. Refer to "Wheels and Tyres" in the General Technical Parameters section.

The spare tyre should maintain the recommended maximum pressure and make adjustments before use. The valve cap must be mounted to prevent dust from entering into the valve.

After a period of time, natural air pressure drop may occur on tyres; if abnormal pressure drop exists, you should immediately identify the cause and correct it.

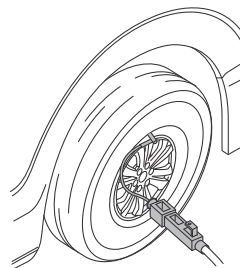

Wear Indicators

There are wear indicators in the treads of the original tyre. When the tyre wears to the degree that the tread is 1.6 mm left, the tread of the entire cross-surface will show wear indicators.

If you see any part of the wear indicator, replace the tyre immediately. Note, however, that the safety and performance of the tyre will be impaired even before the wear indicator is reached. For instance, a seriously worn tyre can increase the risk of slipping.

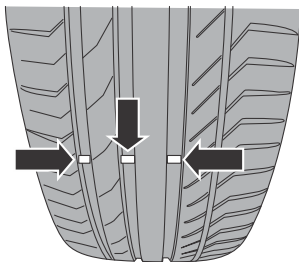

Tyre Check and Rotation

To ensure even tyre wear, it is recommended to have the tyre check every 5,000 kilometers. When uneven tyre wear is found, the tyre position should be changed. After the tyre rotation, check the tyres for proper dynamic balance.

During the tyre rotation, check for uneven tyre wear and damage. Abnormal tyre wear is often the result of incorrect tyre pressure, wheel misalignment, poor wheel dynamic balance, emergency braking or emergency turn. Check the tread or side of the tyre for bruise or bulge; if one of the conditions is found, or the fabric or cord is seen, replace the tyre. After the tyre rotation, adjust the inflation pressure of the front and rear tyres as indicated by the tyre pressure label on the vehicle and check the tightening torque of the wheel nuts.

Tyre Rotation Patterns for Vehicles Equipped with Full-size Spare Tyres

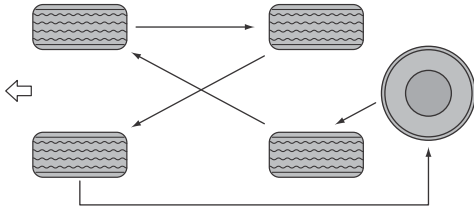

Tyre Rotation Patterns for Vehicles Equipped with Small-size Spare Tyres

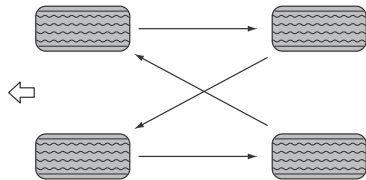

Other Maintenance

Vehicle Wash

! When driving the vehicle for the first time after washing, gently depress the brake pedal several times to remove the water on the brake disc.

Wash the tyres carefully. Don't use high-pressure nozzle because it may damage the tyre. If any damage is found, please replace the tyre.

Don't wash the front part of inner vehicle (adjacent to instrument panel) to avoid unnecessary damage to relevant parts.

The following points contribute to the vehicle value preservation:

- Wash the vehicle with cold or warm water. Hot water may impair vehicle paint in extremely cold weather.
- Don't wash the vehicle under intensive direct sunlight in hot weather.
- Use vehicle-specific cleaner to remove grease and tar spots on the vehicle body. When the body is wet, wash it with a soft sponge and an appropriate amount of water. Rinse thoroughly and wipe dry with a chamois leather.
- When cleaning the vehicle with a hose, it is prohibited to spray the water directly to the window, the door, or the brake through the gap of the wheel.

MAINTENANCE AND SERVICE

- After cleaning, you should check whether there is damage or stone chips on the paint. If necessary, repair the paint. Use polishing wax occasionally to protect the paint surface.
- Keep the sprayer moving when using a high pressure cleaning device. Do not directly wash the engine, radiator, door gap, seals, electrical components or components connected to it.

Note: Please timely remove the substances on the surface of the paint which seem harmless but in fact corrosive, such as bird droppings, resin, insect wreckage, tar spots, road salt and industrial dust. If not removing them timely, stain and damage may be permanently left.

Caution

It is prohibited to open the engine hood and directly rinse the engine compartment, as this may cause short circuits of electrical components in the engine compartment. Don't use steam to clean the underbody, wheelhouse or transmission portion, as this will damage the protective wax layer.

Engine Carbon Deposit Cleaning

In view of the quality of domestic fuel products, it is recommended to use the fuel system carbon deposit cleaner certified by our company every 5,000 km to 10,000 km regularly. Please consult our Service Dealer for details.

Underbody Corrosion Protection

The underbody of your vehicle has been treated with corrosion protection. Check the corrosion protection of vehicle underbody regularly.

You can use a sprayer to clean the dust or mud accumulated on the underbody. Especially in winter, when salt is used on icy and snowy road.

Seat and Interior Trim

Remove dust accumulated on the fibers with a vacuum cleaner or a soft brush frequently. Wipe the interior trim with clean cloth frequently. Ordinary interior dust, spots or stains can be removed using a special cleaner. Clean the leather trim with specialized cleaner.

Door Seals

To prevent rubber door seals from freezing in cold weather, use rubber care products or silicone sprays to protect it.

Windows

Frequently clean the windshield with glass cleaner. The headlamp lens is a transparent plastic material.

Please clean the windows with high-quality cleaner or neutral detergent. Do not use friction agent or chemical solvents.

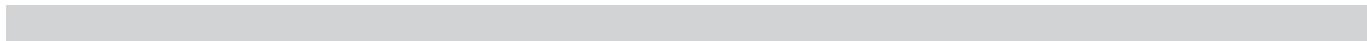

GENERAL TECHNICAL PARAMETERS

- 226 Main Vehicle Dimension Parameters
- 227 Complete Vehicle Mass Parameters
- 228 Complete Vehicle Performance Parameters
- 229 Main Engine Parameters
- 230 Chassis Technical Parameters
- 231 Recommended Fluids
- 232 Wheels and Tyres
- 233 Wheel Alignment Parameters

GENERAL TECHNICAL PARAMETERS

Main Vehicle Dimension Parameters

Driving Type	Unit	4X2	4X4
Length	mm	4985	4985
Width	mm	1926	1926
Height	mm	1867	1867
Wheel Base	mm	2950	2950
Front Track	mm	1590	1590
Rear Track	mm	1620	1620
TCD	mm	<12750	<12750

GENERAL TECHNICAL PARAMETERS

Complete Vehicle Mass Parameters

Product Model	Super	Smart	Sharp	Savvy
Total Mass, kg	2900	2900	3100	3100
Curb weight, kg	2225	2330	2450	2465
Axle load (Front/rear axle load), kg	1140/1085	1190/1140	1250/1200	1280/1185
Number of Seats	5~7			

GENERAL TECHNICAL PARAMETERS

Complete Vehicle Performance and Main Engine Parameters

Engine model	STC (4x2)	DTC (4x4)
Type	In-line 4-cylinder, water-cooled, turbocharged, intercooled, direct injection, diesel engine	In-line 4-cylinder, water-cooled, turbocharged, intercooled, direct injection, diesel engine
Displacement, L	1.996	1.996
Number of Cylinder	4	4
Cylinder Bore, mm	83	83
Stroke, mm	92	92
Volume Compression Ratio	15.9:1	15.9:1
Engine speed at rated power, rev/min	4000	4000
Maximum net power, KW	118.5	158.5
Maximum torque, Nm	375	480
Engine speed at maximum torque, rev/min	1500~2400	1500~2400
Idle speed, rev/min	750±25	750±25
Fuel Type and Grade	0# diesel	0# diesel
Fuel tank capacity, L	75	75
Maximum design speed, km/hour	180	180
Maximum gradability, %	40.4	40.4
Emission level reached when the complete vehicle leaving factory	BS-VI	BS-VI

GENERAL TECHNICAL PARAMETERS

Chassis Technical Parameters:

Item	Parameters
Front Suspension Structure	Double wishbone independent suspension
Rear Suspension Structure	Five-link non-independent suspension
Dynamic Balance Requirements of Steel Wheels	Residual dynamic unbalance allowable at one side: below 10 grams Maximum balance block applied at outer side is 60 grams, and the total of two sides shall not exceed 120 grams
Dynamic Balance Requirements of Aluminum Wheels	Residual dynamic unbalance allowable at one side: below 8 grams Maximum balance block applied at one side is 80 grams, and the total of two sides shall not exceed 160 grams
Rational Range of Brake Pedal Free Stroke	within 10 mm
Rational Use Range of Brake Friction Pair	Friction material thickness is greater than 2 mm





GENERAL TECHNICAL PARAMETERS

Recommended Fluids

Item	Grade	Capacity
Engine lubricating oil, L	SAE 5W-30 ACEA C3	4.7
Engine coolant, L	D-35 (-35°C)	13.5
SC20M2I8Q6A Engine Water-air intercooler coolant, L	D-35 (-35°C)	3.8
8th Automatic transmission oil, L	Shell L 12108	8.77
Brake fluid, L	Laika 901-4 DOT 4	0.66
Washer fluid, L	General low freezing point detergent	2.2
Air conditioning refrigerant, g	R134a	900 ± 30 (with rear internal A/C) 620 ± 30 (without rear internal A/C, dual A/C)
Front axle lubricant, L	TEMPO GL-5 80W-90	0.9
Rear axle lubricant, L	TEMPO GL-5 80W-90	1.74
Transfer case lubricant (all terrain 4WD system), L	MERCON LV	1.5
Diesel Exhaust Fluid (DEF)*	Standard - ISO 22241	Tank capacity 21 litre. Recommended max fill quantity 17litre

GENERAL TECHNICAL PARAMETERS

Wheels and Tyres

Item		Parameters	
Wheel Specification		7.5Jx19	
Tyre Specification		255/55R19	
Tyre Pressure	Front wheels	1-3 	220kPa/2.2bar/32psi
		4-8 	220kPa/2.2bar/32psi
	Rear wheels	1-3 	220kPa/2.2bar/32psi
		4-8 	270kPa/2.7bar/39psi
Spare Tyre Specification		255/55R19	
Spare Tyre Pressure		270kPa/2.7bar/39psi	

GENERAL TECHNICAL PARAMETERS

Wheel Alignment Parameters

Item		Unilateral nominal value and tolerance of four-wheel positioning parameters	Difference between left and right sides of four-wheel positioning parameters
Front wheels	Front camber angle	$0 \pm 0.5^\circ$	$\leq 0.5^\circ$
	Front caster angle	$3.6 \pm 0.5^\circ$	$\leq 0.5^\circ$
	Front toe angle	$0 \pm 0.15^\circ$	$\leq 0.15^\circ$
Rear wheels	Rear toe angle	$0 \pm 0.25^\circ$	/
	Rear camber angle	$0 \pm 0.5^\circ$	/
	Propulsion angle	$0 \pm 0.25^\circ$	/

MG Motor New Vehicle Warranty

Terms & Conditions

INDIA

1. **Warning:**

Your MG MOTOR vehicle is manufactured to meet the regulations and environmental requirements for Indian conditions. In case you relocate it to any other country than INDIA, it may be very difficult to make modifications to comply with the regulations and environmental requirements of that country and it may be difficult to perform repair service in that country.

Please note that a MG Motor vehicle relocated to any other country than India shall not be covered by the warranty.

2. **The MG MOTOR New Vehicle Warranty**

2.1 Duration of MG Motor's New Vehicle Warranty:

Vehicles in the MG Motor range, delivered as new from 1st April 2019 to the Customer by an authorized MG Motor DEALER, are warranted against any material, assembly or Manufacturing Defects by the Manufacturer. The New Vehicle shall be covered under a Warranty by MG Motor for a period of

- **Personal Registration** - 3 years / unlimited* kilometers (whichever is earlier).
- **Commercial Registration** - 3 years or 1,00,000 kilometers (whichever is earlier).

MG Motor new vehicle warranty starts from the Date of sale shown in the delivery document issued to the Customer / First Owner of the vehicle upon delivery of the vehicle purchased. (Transfer of ownership of the vehicle does not alter the warranty period of a vehicle.)

2.2 **Geographical coverage:**

2.2.1 This warranty covers any new vehicle sold within geographical boundaries of INDIA.

If the vehicle is to be driven and, more importantly, registered outside the geographical area defined above, such vehicle will not be covered under the current warranty as stated herein.

2.3 The period of warranty on the vehicle shall not be deemed to be extended by repairs or replacements of any parts.

2.4 In the event the Original Purchaser of the vehicle transfers the vehicle during the period of warranty, it shall be obligation of the subsequent purchaser to notify and inform MG Motor or its authorized dealer of such transfer.

2.4.1 If the vehicle identification number (VIN) of an insured vehicle is declared as total loss by the insurer, any Warranty, Extended Warranty, free services, i-call, e-call and i-smart app (facilities if applicable) provided in respect of such vehicle shall become null and void with effect from the date VIN of such vehicle is declared as total loss by the insurer.

Field of Application:

2.5 **The Customer is covered for:**

2.5.1 Free repair (parts, consumables and labour) of any material or assembly defect duly found in the vehicle, at their own request, as well as any repairs on damage caused by this defect to other vehicle parts.

*For booking before 1st March 2021 and delivery till 30th April 2021, warranty is 3 yrs / 1 lac km (whichever is earlier).

MG MOTOR NEW VEHICLE WARRANTY

2.5.2 24/7 assistance services as defined in the “MG Motor Road Side Assistance” section.

It is the authorized MG Motor Dealer's discretion to decide whether it is appropriate to repair or replace the defective part, whilst keeping the Customer informed.

2.6 **Parts not covered under warranty conditions contained herein:**

Following parts are not covered by warranty conditions contained herein. It is requested to contact your nearest MG Motor Dealer for more details.

2.6.1 **Battery:** The warranty coverage for 12V / 48V Battery is valid for 1 year starting from the Date of sale shown in the delivery document issued to the Customer and shall be provided by the battery manufacturer as per their terms and conditions.

2.6.2 **Tyre:** The warranty coverage for tyre is valid for 1 year starting from the Date of sale shown in the delivery document issued to the Customer and shall be provided by the respective tyre manufacturer as per their warranty terms and conditions.

2.6.3 **Infotainment / Audio system including T-Box:** The warranty coverage for Infotainment / Audio system is valid for 3 year from the Date of sale shown in the delivery document issued to the Customer and shall be provided by the respective manufacturer as per their terms and conditions.

The MG Motor New Vehicle Warranty does not cover and MG Motor India Private Limited (MG Motor) and / or MG Motor authorized workshop shall not be responsible for the following:

2.7 Normal maintenance services other than 3 free services, including without limitation, cleaning and polishing, minor adjustments, engine tuning, oil top-up / fluid changes, Diesel

Exhaust Fluid (DEF) top-up / replacement, filters replenishment, fastener re-tightening, wheel balancing, wheel alignment and tyre rotation etc.

The indirect and remote consequences of any fault (loss of operation, duration of immobilization, etc.);

Vehicle components which have undergone conversion work, and/or specification and design changes and the consequences (deterioration, premature wear and tear, alterations, etc.) of the conversion work on other vehicle parts or components, or on its specifications;

The costs incurred by the Customer for routine maintenance;

Replacement of parts due to normal wear and tear resulting from use of the vehicle or from its mileage including but not limited to clutch, shocker absorbers, wiper blades, brake drum, brake disk, brake pads, brake shoe, lamp, plugs, belts, linings, bulbs, fuses, suspension parts, mountings, parts made of rubber, etc.

Other parts, not limited to steering wheel, gear knobs, gear bellows prone to normal wear & tear will have a limited coverage**

2.8 **Damage or failure resulting due to the following causes:**

2.8.1 Poor vehicle maintenance, in particular if the instructions for the treatment, the frequency of maintenance or care to be applied to the vehicle set out in the delivery document have not been observed;

2.8.2 Due to lack of use / operation of vehicle over prolonged period[s];

MG MOTOR NEW VEHICLE WARRANTY

- 2.8.3** Misuse, abuse, negligence, improper driving habits, theft etc. of the vehicle;
- 2.8.4** Damage from stress, like use of vehicles in races, rallies or as taxis. The warranty terms for the use of MG Motor vehicle shall be different / separate from the terms contained herein.
- 2.8.5** Use of parts other than MG Motor Genuine Parts.
- 2.8.6** Any device and / or accessories not Supplied / Fitted by MG Motor.
- 2.8.7** Modifications, alterations, tampering or improper repair.
- 2.8.8** Parts used in applications of which they were not designed or not approved by MG Motor.
Slight irregularities not recognized as affecting quality or function of the vehicle or parts, such as slight noise or vibrations, or items considered characteristic of the vehicle.
- 2.9** **Damage caused by the following external causes:**
- 2.9.1** Accidents, impacts, scratches, scoring, projection of gravel or solid bodies, hail, acts of vandalism;
- 2.9.2** Failure to observe the Manufacturer recommendations;
- 2.9.3** Deposits due to atmospheric pollution, plant-based deposits such as resin, animal-based deposits such as bird droppings, chemical deposits;
- 2.9.4** Transportation of the vehicle;
- 2.9.5** Using an adulterated / incorrect fuel;
- 2.9.6** Fitting accessories not approved by the manufacturer;
- 2.9.7** Fitting accessories approved by the manufacturer, but installed without observing the recommendations defined by the manufacturer;
- 2.9.8** Damage due to airborne fallout, industrial fall out, acid rain, hail and wind storms, or other force majeure events like lightning, fire, floods, earthquakes, war, riots, attacks etc.;
- 2.9.9** Damage caused due to hydro-static lock.
- 2.9.10** Damage caused due to rodents;
- 2.9.11** Paint scratches, dents or similar paint or body damage.
Incidental or consequential damages, including without limitation, loss of time, inconvenience, loss of use of vehicle or commercial loss.
- How does the MG MOTOR New Vehicle Warranty work?**
- 2.10** To be eligible for the MG Motor New Vehicle Warranty, the Customer must:
- 2.10.1** Check that the delivery document does contain the Date of sale of the vehicle - their warranty entitlement is dependent on this;
- 2.10.2** Contact any workshop of the MG Motor Authorized Workshop Network - only such Workshop have the authorization for operations of this sort;
- 2.10.3** Show the duly completed delivery document, as proof of entitlement to the warranty and that the maintenance operations recommended by the Manufacturer have been carried out;
- 2.10.4** Have the defect covered by the MG Motor New Vehicle Warranty confirmed as soon as possible, by a MG Motor authorized workshop in writing. If the vehicle is un-roadworthy, the Customer must contact the nearest MG Motor authorized workshop member or MG Motor Assistance.
- 2.11** The MG Motor New Vehicle Warranty does not apply, and MG

MG MOTOR NEW VEHICLE WARRANTY

Motor and MG Motor authorized dealer members are exempt from all liabilities, if:

- 2.11.1** The vehicle has been driven under conditions not in accordance with those stated in the Owner's Manual (example: vehicle overloaded or taking part in any type of sports competition, etc.);

The defect observed is due to the Customer having had the vehicle repaired or serviced in a workshop outside the MG Motor authorized network and not observing MG Motor's recommendations on the subject.

- 2.12** By way of consideration for the parts supplied by MG Motor under the MG Motor New Vehicle Warranty, parts replaced under this warranty, shall legally become the property of MG Motor.

- 2.13** All operations, parts and labour, carried out under the MG Motor New Vehicle Warranty are guaranteed until the new vehicle warranty expires.

- 2.14** Transferring ownership of the vehicle shall not alter the application conditions of the MG Motor New Vehicle Warranty.

3. The MG MOTOR Anti-corrosion Warranty:

- 3.1 Duration of the Anti-Corrosion Warranty:** This warranty will apply from the Date of sale given on the delivery document for a period of:

- **Personal Registration** - 3 years / unlimited* kilometers (whichever is earlier).
- **Commercial Registration** - 3 years or 1,00,000 kilometers (whichever is earlier).

- 3.2 Geographical Coverage:** The geographical coverage of the Anti-Corrosion Warranty is identical to that for the MG MOTOR New Vehicle Warranty.

3.3 Anti-corrosion Warranty field of application

- 3.3.1** In addition to the MG Motor New Vehicle Warranty, MG Motor guarantees the bodywork and sub frame of MG Motor vehicle from perforation from the interior, due to steel panel corrosion caused by a manufacturing, material or protective product application defect.

- 3.3.2** This guarantee covers the repair or replacement of components with perforated steel panel work due to a manufacturing, material or protective product application defect, acknowledged by the Manufacturer.

- 3.3.3** It is authorized MG Motor workshop's discretion to decide whether it is appropriate to repair or replace these components, and to inform the Customer.

3.4 The MG MOTOR Anti-Corrosion Warranty does not cover:

- 3.4.1** Any damage which is not covered by the MG Motor New Vehicle Warranty, as defined in new vehicle warranty terms and conditions Mechanical components.

which are not an integral part of the bodywork or sub-frame (wheel rims, exhaust system, etc.).

- 3.4.2** In case, repairs (including denting or painting) have been carried out on the body of the MG Motor Vehicle in a workshop outside the MG Motor authorized network.

3.5 Anti-Corrosion Warranty conditions of application

MG MOTOR NEW VEHICLE WARRANTY

- 3.5.1 To obtain the Anti-Corrosion Warranty, the Customer must contact any Workshop of the MG Motor Authorized Workshop Network - only such Workshop have authorization for operations of this sort.
- 3.5.2 The Customer shall show the duly completed delivery document (date of sale) as proof of their warranty entitlement.
- 3.5.3 Application of the MG Motor Anti-Corrosion Warranty is subject to the anti-corrosion tests on the bodywork and sub-frame. Customer shall ensure that these tests are conducted at least once every two years.
- 3.5.4 If the Customer requests to have the anti-corrosion test conducted independently of the scheduled maintenance service, the same will be carried out at an extra cost to the Customer.
- 3.5.5 During these tests the Customer shall make sure that the professional carrying out the operation correctly completes the bodywork and sub frame test, in order to validate the continuation of the Anti-corrosion Warranty.
- 3.5.6 Repairs on any deterioration must be made as soon as possible.
- 3.5.7 The application of the MG Motor Anti-Corrosion Warranty is also subject to bodywork and sub-frame repairs being carried out in accordance with MG Motor recommendations.
- 3.5.8 The repair or replacement of components under the conditions described in the “field of application” (Paragraph 3.3), shall taken into account the general condition of the vehicle with regard to its age, mileage and maintenance level.
- 3.5.9 Parts replaced under the Anti-corrosion Warranty legally become the property of MG Motor.

- 3.5.10 Repairs and components fitted under the Anti-Corrosion Warranty are guaranteed until the end of the term of the original Anti-corrosion Warranty.
- 3.5.11 Transferring ownership of the vehicle does not alter the application conditions of the Anti-corrosion Warranty.

The MG MOTOR Paintwork Warranty:

- 3.6 **Duration of the Paintwork Warranty:** MG Motor guarantees the body paintwork and painted parts paintwork (door mirrors, bumpers etc.) for 3 years / unlimited* kilometers (whichever is earlier) and 3 years or 1,00,000 kms (for Commercial Registration) (whichever is earlier) from the Date of sale of the new vehicle.
- 3.7 **Geographical Coverage:** The geographical coverage of the Paintwork Warranty is identical to that for the MG Motor New Vehicle Warranty.
- 3.8 **Paintwork Warranty field of application:**
- 3.8.1 This warranty covers the free repair or replacement of components with inherent paintwork defects (deterioration of lacquer or finishing varnish, due to any material, manufacturing or application defect) acknowledged by the Manufacturer, with the MG Motor authorized workshop carrying out the operation, keeping the Customer informed.
- 3.8.2 This repair shall take into account the general condition of the vehicle with regard to its age, mileage and maintenance level.
- 3.9 **The MG Motor Paintwork Warranty does not cover:**
- 3.9.1 Any damage which is not covered by The MG Motor New Vehicle Warranty, as defined in new vehicle warranty terms and conditions;

*For booking before 1st March 2021 and delivery till 30th April 2021, warranty is 3 yrs / 1 lac km (whichever is earlier).

MG MOTOR NEW VEHICLE WARRANTY

3.9.2 Damage due to (but not limited to) force majeure events: lightning, fire, floods, earthquakes, war, riots and attacks;

3.9.3 Mechanical components which are not an integral part of the bodywork or sub-frame (wheel rims, exhaust system, etc.).

Damage due to action of road elements (sand, gravel, dust or road debris) which results in stone chipping of paint or glass.

3.9.4 In case, the denting or painting job has been carried out on the MG Motor Vehicle in a workshop outside the MG Motor authorized network.

3.10 Paintwork Warranty conditions of application

3.10.1 To obtain the Paintwork Warranty, the Customer must contact any workshop of the MG Motor Authorized Workshop Network - only such Workshop have authorization for operations of this sort.

3.10.2 The Customer shall show the duly completed delivery document (date of sale) as proof of their warranty entitlement.

3.10.3 By way of consideration for the parts supplied by MG Motor under the Paintwork Warranty, parts replaced under this warranty legally become the property of MG Motor.

3.10.4 Repairs and components fitted under the Paintwork Warranty are guaranteed until the end of the term of the original Paintwork Warranty.

3.10.5 Transferring ownership of the vehicle does not alter the application conditions of the Paintwork Warranty.

4. This warranty is the entire Warranty given by MG Motor and no Authorized Dealer of MG Motor or its or his agent or employee is authorized to extend or enlarge this warranty and no Authorized Dealer of MG Motor or its or his agent or

employee is authorized to make any oral warranty on MG Motor's behalf.

5. MG Motor reserves the right to make any change in design or make any improvement in the design, structure, technology etc. of the vehicle at any time without any obligation to make the same change on the vehicles already sold.

6. Warranty service shall be provided only by MG Motor's Authorized Dealers and Dealer Service Branch.

7. MG Motor's decision is final and binding on the Owner of the vehicle in all warranty matters. MG Motor reserves the right for the final decision on all warranty matters.

8. The terms and conditions as contained herein shall be construed in accordance to the laws as applicable in India and all disputes arising out of this Warranty will be subject to the jurisdiction of Courts in Gurugram only.

Disclaimer

MG Motor India has partnered with multiple application services & content providers for developing the complete/overall ecosystem experience of Internet Car features across all MGI models*. MG Motor India is committed to providing the best user experience and services and acts as an integrator for these application services & content providers. For any customer feedback, MG Motor India will coordinate with the respective content/service provider for resolution.

***Model variants applicable with Internet features.**

**** for limited coverage details, please contact MG authorised service center**

MG Roadside Assistance 24x7

CALL 1800-100-6464

MG Roadside Assistance is designed to enhance your overall MG ownership experience, by providing you with 24hrs / 7days emergency support related to the use of your MG Motor Vehicle. Peace of mind motoring-guaranteed.

While it is our sincere hope that your travels are always trouble-free, breakdowns and road traffic accidents do happen - our goal is to ensure that even if your MG is immobilized, whether at home or while travelling, any inconvenience to you and your family is minimized.

Should you ever require assistance, all you need to do is dial our 24-hour assistance hotline: 1800 100 6464 and / or press the Call button on your car and MG Roadside Assistance will be there to help. Vehicles will be covered under this program for a period of 3 years from the Date of sale of the vehicle.

Getting Help – What to do when you need Assistance

In the event of a breakdown or accident, simply call MG Roadside Assistance on 1800 100 6464 (toll-free from anywhere in India), or press the Call button on your car. When placing the call, please have the following information handy for assisting the operator in analysing the issue:

- Description of the problem;
- Your location;
- Registered Contact phone number, in case you are calling from a number other than your registered number, as registered with MG;
- License plate number

if you opt for your own vehicle assistance / recovery management, the cost for the same shall be borne by you.

Covered Events

- Mechanical or electrical breakdown leading to stoppage/immobility of the vehicle
- Human error
 - Key problems: locked keys, lost keys, or broken vehicle keys
 - Tyre problems: puncture, bolts or valve related issues
 - Battery problems: flat battery
 - Fuel problems: out of fuel, incorrect fuel, or contaminated fuel (Twice a year, up to 5 lit)
 - Road traffic accident where the vehicle is immobilized

Assistance will be provided no matter where you are (i.e. at home, on the roadside, on the highway, in a parking lot, etc.), as long as you are not already at an Authorized MG Dealer.

SUMMARY OF CUSTOMER BENEFITS

Roadside Assistance at home or on the road

If your vehicle is immobilized, whether at home or on the road, MG Roadside Assistance will attend to your vehicle. For conditions where we decide that the cause of the breakdown/immobilizations can be solved at the roadside, a technician will be sent to try and mobilize your vehicle at your location.

Vehicle Recovery

If your vehicle is unable to be mobilized following a mechanical or electrical breakdown, a recovery vehicle will be sent to recover your vehicle to the nearest authorized MG dealer.

ROADSIDE ASSISTANCE

Taxi

If your vehicle is recovered to an authorized MG Dealer, MG Roadside Assistance will also provide taxi assistance.

Custody Services

If towing is delayed, or if the technician on spot is unable to fix your vehicle, MG Roadside Assistance will arrange for a personnel to take custody of your vehicle.

Vehicle Recovery following an Accident

If your vehicle is unable to be mobilized following a road traffic accident, MG Roadside Assistance will organize to send a recovery vehicle to recover your vehicle from the accident site to the nearest authorized MG Dealer.

Vehicle Repatriation

In the event of the Covered Vehicle experiencing a breakdown/ accident beyond 100km from homecity, and the vehicle being towed to nearest authorized workshop, post repair customer & bill being settled by customer vehicle can be delivered back to customer location upto 200 kms.

Medical Coordination

In case of a medical assistance required by you during the breakdown, MG Roadside Assistance team will help for the medical coordination.

Accommodation Assistance

In case of a breakdown occurring far from your hometown (not less than 100 kilometres), and if so needed by you, MG Roadside Assistance will help provide a hotel accommodation for you for one night.

Onward Travel

in the event of the Covered Vehicle experiencing a breakdown/accident beyond 100km from home city, and the vehicle being towed to an

authorized workshop, customer can be provided onwards travel to/ back to destination. Mode of travel can be Air/ Rail/ Road. Subject to distance being max of 500kms. (maximum of legal carrying passenger).

Program Overview

Definitions

- **Covered Customers:**

The owner (or driver) and all the passengers travelling in the vehicle at the moment the roadside assistance was required, up to the legal passenger limit of the vehicle. The customer may be asked to produce car/other identity documents to verify the eligibility under this Program.

- **Covered Vehicles and period of cover:**

All new MG vehicles sold by Authorised MG Dealers in India are eligible for free MG Roadside Assistance with Pan India coverage (except islands, areas with limited entries). Vehicles will be covered under this program for a period of 3 years from the date of sale of the vehicle.

Assistance will be provided no matter where you are (i.e. at home, on the roadside, on the highways, in a parking lot, etc.), as long as you are not already at an Authorized MG Dealer.

Non-covered Events

MG Roadside Assistance is designed to help only in “covered events” that lead to stoppage / immobilization of your vehicle. As a result, this program will not cover following events, including but not limited to:

- Faulty fuel gauge
- Speedometer not working
- Air-conditioning is not working
- Passenger door(s) cannot be opened when there are no

ROADSIDE ASSISTANCE

- passengers in the vehicle
- Boot cannot be opened
- Front and / or rear demisters are not functioning
- Horn is not functioning
- Damaged door mirrors
- Rear view mirror is damaged, but it does not obstruct the driver's vision
- Damaged or faulty fuel cap but vehicle has not run out of petrol and there is enough fuel in the tank to enable the vehicle to reach the nearest Authorized MG Dealer
- Sunroof cannot be opened
- Sunroof cannot be closed but weather conditions are fair, and the vehicle is not exposed to any security risk
- Windows cannot be opened
- Windows cannot be closed but weather conditions are fair, and the vehicle is not exposed to any security risk
- Seat adjuster is faulty, but the vehicle can be safely driven
- Passenger seat belts are faulty but there are no passengers in the vehicle
- Faulty security system unless the vehicle is immobilized or unless the alarm is sounding continuously
- ABS lights are illuminated
- Air bag warning lights are illuminated
- Traction control lights are illuminated
- Other non-safety related lights/service warnings are illuminated
- Vehicle runs out of windscreen wiper fluid

- Front or rear windscreen wipers faulty but weather conditions are fair

General Exclusions

The following scenarios are general exclusions under the MG Roadside Assistance and therefore MG Roadside Assistance will not be responsible for any assistance costs as a result of any of the following:

- Vehicle is involved in motor racing, rallies, speed or duration tests, practice runs, or operated outside, subject to the exclusivities provided herein and in the owner manual;
- Assistance is required as a result of wars, riots, uprising, mass political demonstrations, pillage, strike, use for military purposes or acts of terrorism, earthquake damage, freak weather conditions, atmospheric phenomena, nuclear transformation phenomena or radiation caused by artificial acceleration of atomic particles;
- Breakdown is caused by deliberate damage, or participation or abetment in a criminal act or offence;
- The immobilization is resulting from damage caused by intervention of the police or other authorities;
- Any damage resulting from the use of the vehicle against the recommendations of the owner manual;
- Any consequential costs and / or damage to property as a result of a breakdown;
- Vehicles kept in a non-roadworthy condition or not serviced in accordance with the manufacturer's recommendations;
- The damage / immobilization is caused due to any repair work done on the vehicle is from a workshop which is not a member of the MG Authorised Workshop Network;
- The damage / immobilization is caused to the vehicle due to the

ROADSIDE ASSISTANCE

negligence / intentional driving of the vehicle or tampering with the vehicle, even after becoming aware of the breakdown / fault / damage.

- If the vehicle identification number (VIN) of an insured vehicle is declared as total loss by the Insurer, the Roadside Assistance (RSA) provided in respect of such vehicle shall become null and void with effect from the date VIN of such vehicle is declared as total loss by the insurer.

General Terms and Conditions

Remain with your Vehicle

- Once you have called MG Roadside Assistance, it is vital that you stay with your vehicle. Should the MG Roadside Assistance representative arrive at your vehicle while it is unattended, the necessary work will not be carried out.

Adverse Weather

- On occasion, adverse weather conditions such as floods, heavy rain, thunder / lightning, other natural calamities or other external factors may affect our ability to provide services and it may become physically impossible to assist you until the weather improves. During such times, our main priority will be to ensure that you and your passengers are taken to a place of safety; the recovery of your vehicle may not be possible until weather conditions permit.

External Factors

- MG will take every effort to reach you once you make the call however external conditions (including traffic, strike etc.), could delay such an effort.

Locked Keys

- Whilst we will always endeavour to provide assistance by the most efficient method, modern security systems sometimes make it extremely difficult for us to gain entry to your vehicle at the roadside should the spare keys not be available. If a forced emergency entry is required, you will be asked to sign a declaration stating that you have granted permission for this to take place and confirming that all costs relating to any resulting damages to your vehicle will be your sole responsibility.

Replacement Costs

- The replacement cost for any damaged part of the vehicle shall not be covered by MG Roadside Assistance, unless it is covered under any other warranty(ies) provided by MG Motor, including the new vehicle warranty, as may be applicable and / or subscribed to by the owner of the MG vehicle.

Right of Refusal

- MG Roadside Assistance shall have the right to refuse any or all benefits under the program, if it is found that you had furnished false information relating to your eligibility or entitlements to the benefits provided under this program.

Disputes

- Courts situated within the jurisdiction of Gurugram alone shall have the exclusive jurisdiction to decide all disputes that may arise under this service.

CHANGE OF OWNERSHIP RECORD

Change of Ownership Record

Model _____

Registration or
License Number | | | | | | | | | | | | | | | | | | | | | |

VIN _____

New Owner's Name _____

New Owner's Address _____

Telephone No. _____

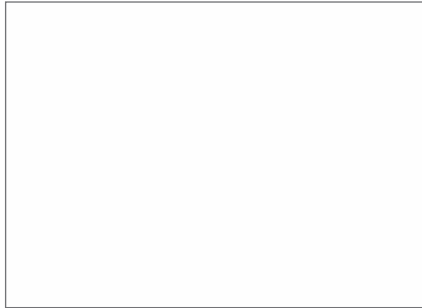

If resold by MG Motor Dealership
Enter Dealer Stamp in Box above

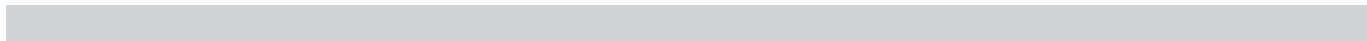

MAINTENANCE INTERVAL

GLOSTER - PERIODIC MAINTENANCE SCHEDULE (First 3 Periodic Services are Labour Free)

Years		1 Month*	6 Months*	1 Year*	2 Year	3 Year	4 Year	5 Year	6 Year	7 Year	8 Year	9 Year	10 Year
Operation / Processes for Periodic Maintenance Schedule	Replacement / Inspection Frequency: Year / Kilometre (whichever is earlier)	1000*	5000*	15000*	30000	45000	60000	75000	90000	105000	120000	135000	150000
Engine Oil	Replace in 6 Month / 5000 Km. Subsequent replacement in every service	I	R	R	R	R	R	R	R	R	R	R	R
Oil Filter	Replace in 6 Month / 5000 Km. Subsequent replacement in every service		R	R	R	R	R	R	R	R	R	R	R
Fuel Filter and O Ring	3 Years / 30000 Kms				R		R		R		R		R
Washer Drain Plug	1 Year / 15000 Kms			R	R	R	R	R	R	R	R	R	R
Air Filter Element	2 Years / 30000 Kms		I	I	R	I	R	I	R	I	R	I	R
Pollen / AC Filter	2 Years / 30000 Kms			I	R	I	R	I	R	I	R	I	R
Brake Oil / Clutch Fluid	3 Years / 60000 Kms	I		I	I	R			R			R	
Acc Belt condition / tightness	Inspect every service			I	I	I	I	I	I	I	I	I	I
Timing Belt, Tensioner	Replace every 6 years / 90000 Kms							I	R				I
Pulley	Inspect every 5 Years / 75000 Kms							I					I
Coolant Change (11.5 Litre)	4 Years / 60000 Kms	I	I	I	I	I	R	I	I	I	R	I	I
WS Washer Fluid	1 Year / 15000 Kms	I	I	R	R	R	R	R	R	R	R	R	R
Transfer Case Lubricating Oil	Replace at 75000 Kms. Subsequent replacement after every 100000 Kms							R					
Front Axle Lubricating Oil	Replace at 5000 Kms. Subsequent replacement every 3 Years / 90000 Kms		R			R			R			R	
Rear Axle Lubricating Oil	Replace at 5000 Kms. Subsequent replacement every 3 Years / 90000 Kms		R			R			R			R	

MAINTENANCE INTERVAL

Years		1 Month*	6 Months*	1 Year*	2 Year	3 Year	4 Year	5 Year	6 Year	7 Year	8 Year	9 Year	10 Year
Operation / Processes for Periodic Service Schedule	Replacement / Inspection Frequency: Year / Kilometre (whichever is earlier)	1000*	5000*	15000*	30000	45000	60000	75000	90000	105000	120000	135000	150000
Vehicle Software Update*	Every service	U	U	U	U	U	U	U	U	U	U	U	U
Steering Geometry / Wheel Balancing / Rotation / Tyre Pressure	Every Service			I	I	I	I	I	I	I	I	I	I
Check the DTC, Diagnos, Inspect and clear the all DTC	Every Service	I	I	I	I	I	I	I	I	I	I	I	I
Check Fuel lines for Leakages	Every Service	I	I	I	I	I	I	I	I	I	I	I	I
Check HVAC for Satisfactory Performance	Every Service	I	I	I	I	I	I	I	I	I	I	I	I
Check front & rear Brake pad	Every Service			I	I	I	I	I	I	I	I	I	I
Nitrogen - Oxygen Sensor	Inspect and clean if required		I	I	I	I	I	I	I	I	I	I	I
Sunroof Operation	Special maintenance item	Clean the guide rails and apply special grease when necessary, check for water drain function of sunroof, and clean as required.											

Topping of Diesel Exhaust Fluid (DEF) (not a part of periodic maintenance schedule)	5000	15000	30000	45000	60000	75000	90000	105000	120000	135000	150000
Check and if necessary, top up additive for emission reduction (Diesel Exhaust Fluid - DEF). (Tank capacity 21 litre. Recommended max fill quantity 17 litre.) For more information on DEF, refer the Owner's Manual Diesel Exhaust Fluid (DEF) section.	I	I	I	I	I	I	I	I	I	I	I

Symbol Abbreviation: • R - Replace • U - Check for Vehicle Software version and Update (including campaigns) if required • I - Inspect (Top up if required/Adjust/Clean/Gap setting/Clean) • NA: Not applicable
• * Labour Free Services.

Tightening of underbody fasteners, door adjustments and functional checks of all the systems during every service is mandatory.

Check the coolant level and top up as required, replace if it is contaminated/ discoloured or there is sludge formation.

Filters, Fluid, Diesel Exhaust Fluid (DEF), Consumables, Components, Wheel Alignment, Wheel Balancing etc. (but not limited to mentioned) will be replaced on chargeable basis.

Transmission oil is maintenance free through all life cycle. Top up as required.

MAINTENANCE INTERVAL

Additional Maintenance General Checkpoints

No.	General maintenance requirements for driving under normal conditions	Frequency of Inspection	
		5,000 Km / 6 months (Whichever is earlier)	Every 15,000 Km / 1 Year (Whichever is earlier)
1	Check for reliable and effective fixings and retainers of front and rear suspension	✓	✓
2	Check for reliable and effective connections of steering track rod, ball joint and knuckle retaining bolts	✓	✓
3	Check for complete and effective light signal, instrument display, electrical device functions	✓	✓
4	Check for battery level and charging and check and clear battery terminals, tightened when necessary	✓	✓
5	Check for damaged air bag surface and reliable and effective seat belt functions	✓	✓
6	Check for clamps at both ends of inter-cooler pipe, and re-tighten them with a torque of 5Nm	✓	✓
7	Road test: performance test	✓	✓
8	Check for exhaust pipe connection is secured reliably and effectively and rubber shackles of exhaust pipe are aged and broken	✓	✓
9	Check for disturbance and damage of vacuum system pipeline	✓	✓
10	Check for engine compartment harness is secured reliably and effectively without disturbance and damage	✓	✓
11	Check for transmission shaft universal joint gaiter	✓	✓
12	Clean carbon deposits on oxygen sensor probe	✓	✓
13	Check for reliable and effective operation of engine crankcase ventilation system		✓
14	Replace propeller shaft damper every 200,000 km (applicable to the model equipped with propeller shaft damper)	Special maintenance item	

Note:

1. The inspection given above are in addition to the Periodic Maintenance Schedule. These are mandatory checks to be done at specified intervals as given above.
2. The maintenance content of this table is applicable to our company manufactured series vehicle and selection of maintenance items shall depend on vehicle features.
3. The maintenance interval of air filter element and AC ventilation system element shall be shortened for vehicles running in the environment full of dust.
4. Tyre rotation every 15,000 km based on tyre wear and then tyre pressure correction.

MAINTENANCE RECORD SHEET

(Repair Category - Free Service / Paid Service / Running Repair / Accident Repair)

Repair Date	R.O. No.	Kms.	Repair Category	Details of Repair Done	Name of Servicing Retailer	Service Adv. Sign.	Retailer Stamp

MAINTENANCE RECORD SHEET

(Repair Category - Free Service / Paid Service / Running Repair / Accident Repair)

Repair Date	R.O. No.	Kms.	Repair Category	Details of Repair Done	Name of Servicing Retailer	Service Adv. Sign.	Retailer Stamp

MG MOTOR INDIA SALES AND SERVICE NETWORK

ANDHRA PRADESH

MG Vijayawada
Jayalakshmi Auto Enterprises Pvt. Ltd.
3S Door # 1-136/3, Gudavalli Junction, NH 16
Service Road, Gudavalli, Vijayawada - 521104

MG Vizag
Tristar Auto Agencies (Vizag) Pvt. Ltd.
1S Beside Kali Matha Mandhir, RK Beach
Junction, Visakhapatnam - 530002

MG Vizag Service
Tristar Auto Agencies (Vizag) Pvt. Ltd.
2S Plot No: D-36, Industrial Estate, Marripalem,
Visakhapatnam - 530018

MG Tirupati
Keshvin Auto Motors Pvt. Ltd.
3S 717/B2F1, 200 Feet By-Pass Road,
Thukivakam, Tirupati - 517501

MG Rajahmundry
Jayalakshmi Auto Enterprises Pvt. Ltd.
3S 81-51-06 NH 16 Service Road, Sri
Venkateshwara Nagar

MG Nellore
Keshvin Auto Motors Pvt. Ltd.
Z-Next 3S
Sy no 525/2 buranpur , Nellore- Chennai
bypass , Bhuj Bhuj Nellore

MG Guntur
Jayalakshmi Auto Enterprises Pvt. Ltd.
Z-Next 3S
No 36, Phase IV Autonagar, Next to Royal
Enfield Showroom, Guntur - 522001

ASSAM

MG Guwahati
Karini Ventures Pvt. Ltd.
1S Royal Orchid, NH37, Near Garchuk Police
Station, Garchuk, Dhirenpara,
Guwahati - 781035

MG Guwahati Service
Karini Ventures Pvt. Ltd.
2S AK Deb Road, Katabaril, Gorchuk,
NH 37, Guwahati - 781035

MG Dibrugarh
Karini Ventures Pvt. Ltd.
Z-Next 3S
AT Road, Opposite Thermal Power Station,
Dibrugarh - 786001

BIHAR

MG Patna
Ashiana Fabicon Pvt. Ltd.
1S Ground Floor, "Ashiana Vihar" Apartment,
Near CDA Building, Rajendra Path,
Patna - 800001

MG Patna Service
Ashiana Fabicon Pvt. Ltd.
2S Anisha Bad Main, Patna - 800 002

MG Muzaffarpur
Ashiana Fabicon Pvt. Ltd.
Z-Next 3S
Shakri Saraiya, Bihar - 843165

CHATTISGARH

MG Raipur
Shivaaya Cars Pvt. Ltd.
3S Ring Road No.1, Raipura, Raipur-492099

MG Bilaspur
Shivaaya Cars Pvt. Ltd.
3S MG Motors Bilaspur, NH 130, Raipur Main
Road, Siringitti, Bilaspur

MG Ambikapur
Shivaaya Cars Pvt. Ltd.
Z-Next 2S
Industrial Estate, Near Holly Cross School,
Beside of Laxmi Borwell Banaras Road
Ambikapur, Distt. - Surguja - 497001

MG MOTOR INDIA SALES AND SERVICE NETWORK

DELHI

- MG Delhi South Safdurjung Sai Shreeja Cars Pvt. Ltd.**
 IS B-1/4 Safdarjung Enclave
- MG Delhi West Shivaji Marg MG Cars Pvt. Ltd.**
 IS Plot no 31, Najafgarh Road, Industrial Area, Shivaji Marg, New Delhi - 110015
- MG Lajpat Nagar Sai Shreeja Cars Pvt. Ltd.**
 EC A-14, Ring Road, Lajpat Nagar- IV, New Delhi - 110024
- MG Delhi West Rohini MG Cars Pvt. Ltd.**
 EC A1/1, Prashant Vihar Outer Ring Road Delhi - 110085
- MG Patparganj Crystal Autocars Pvt. Ltd.**
 EC Plot No 24, Block No 1, Functional Industrial Estate, Patparganj, Delhi - 110092
- MG Delhi South Service Sai Shreeja Cars Pvt. Ltd.**
 2S B-67, Phase-I, Okhla, New Delhi - 110020
- MG Delhi West Service MG Cars Pvt. Ltd.**
 2S 7/20, Kirti Nagar, Ind Area, Delhi - 110015

MG Okhla Bodyshop

Sai Shreeja Cars Pvt. Ltd.

- 2S D-1, Okhla Industrial Area, Phase -I, New Delhi - 110 020

MG North Jahangirpuri Service (Mechanical+Bodyshop) MG Cars Pvt. Ltd.

- 2S Plot No. 5, Small Scale Co-operative Industrial Area, G.T Karnal Road, Delhi

GOA

- IS **MG Goa Priority Auto Lincs Pvt. Ltd.**
 Survey no.166/1, New Taleigao bypass road, Opp. Taleigao Community Centre. Taleiga-Goa - 403002
- 2S **MG Goa Service Priority Auto Lincs Pvt. Ltd.**
 Survey no.132/1-C, Behind Healthway Hospital, SE Old Goa, Tiswadi Goa - 403108
- MG Margao Priority Auto Lincs Pvt. Ltd.**
 Z-Next 2S
 Plot No U 02-J & U 02-K, Phase 4, Verna Industrial Estate, Verna, Goa - 403722

GUJARAT

- MG Ahmedabad SG Highway Concept Motor Garage Pvt. Ltd.**
 IS Plot No 2, Ground Floor, Survey No 841/1 and 2, 10, Signature 1, Near Old Railway Line, SG Highway, Makarba, Ahemdabad - 380051
- MG Surat Nanavati Autosquare Pvt. Ltd.**
 IS Ground Floor, Icon Business Centre, Opposite Central Mall, Piplod Dumas Road, Surat - 395007
- MG Surat Service Nanavati Autosquare Pvt Ltd**
 2S Plot # 220-328,Bhatpore GIDC, Behind Nanavati Toyota, Magdala Hazira Road, Surat - 394510
- MG Vadodara Kayakalp Cars Pvt. Ltd.**
 IS Zorba, Akshara Chowk, OP Road, Vadodara - 390012
- MG Rajkot Jai Ganesh Autocars Pvt. Ltd.**
 IS Jai Ganesh MG. Opp Krishna Park, Rajkot-Gondal Highway, Kothariya, Rajkot - 360003
- MG Vapi Nanavati Autosquare Pvt. Ltd.**
 3S Survey No 56/1/1, Opp Avadh Utopia, NH-8, Salvav, Vapi, Tal-Pardi, Dist-Valsad - 396195

MG MOTOR INDIA SALES AND SERVICE NETWORK

- MG Gandhinagar**
Concept Motor Garage Pvt. Ltd.
IS Plot No 29 Old GTS Road NR Thermal
Power Station Sector 30 Gandhinagar
- MG Gandhinagar Service**
Concept Motor Garage Pvt. Ltd.
IS Survey No. 600, Nr.Valad,
Gandhinagar - 382355
- MG Ahmedabad Naroda**
Concept Motor Garage Pvt. Ltd.
EC GF-4, Neelkanth Square, Nr.Railway Crossing,
NH8, Naroda, Ahmedabad - 382330
- MG Ahmedabad Service**
Concept Motor Garage Pvt. Ltd.
2S Survey No 321, Anuj Estate, Opp. Essar Petrol
Pump, S.P. Ring Road, Sanathal
Ahmedabad - 382210
- MG Vadodara Service**
Kayakalp Cars Pvt. Ltd.
2S 362 GIDC Makarpura, Vadodara-390010
- MG Rajkot Service**
Jai Ganesh Autocars Pvt. Ltd.
2S Jai Ganesh MG, Near Jagannath Marble, Rajkot
Gondal Highway, Kothariya, Rajkot - 360003
- MG Ambawadi**
Concept Motor Garage Pvt. Ltd.
IS GF, Ashwamegh Elegance, Opposite SBI Zonal
Office, Ambawadi, Ahmedabad

- MG Bhavnagar**
Jai Ganesh Autocars Pvt. Ltd.
Z-Next 2S
Plot no:404, Rajkot-Bhavnagar Highway,
Opp:Viraj Farm, Vartej-Bhavnagar - 364060

- MG Anand**
Kayakalp Cars Pvt. Ltd.
Z-Next 3S
Near Jay Ambe Nagar Society, Rajodpura,
Chikhodra - 388001

- MG Mehsana**
Concept Motor Garage Pvt. Ltd.
Z-Next 3S
Near Celebration Party Plot, Opposite Green
Meadows, Ahmedabad – Mehsana Highway,
Mehsana - 384002

- MG Bharuch**
Nanavati Autosquare Pvt. Ltd.
Z-Next 3S
Nanavati Auto Square Pvt Ltd, LS56/A, NR,
Reliance Petrol Pump NH08, Vagusana,
Bharuch - 393010

- MG Jamnagar**
Jai Ganesh Autocars Pvt. Ltd.
Z-Next 3S
Opp: Yamuna Petroleum, Hapa Industrial
Area, Rajkot-Jamnagar Highway, Hapa-
Jamnagar - 361120

- MG Himmatnagar**
Concept Motor Garage Pvt. Ltd.
Z-Next 3S
Survey No 97/3, N.H No. 8, Piplodi,
Himmatnagar - 383001

- MG Gandhidham**
Jai Ganesh Autocars Pvt. Ltd.
Z-Next 3S
122, Rabindranath Tagore Rd, Ward 5,
Adipur, Gandhidham - 370205

HARYANA

- MG Gurgaon Flagship Showroom**
Cargo Motors(Kutch) Pvt. Ltd.
IS Sector 15 Part 2, Gurugram, Haryana 122022

- MG Karnal**
Rahul Garages LLP
3S Adjoining Sudhanshu ji Maharaj Ashram, Near
Devi Lal Chowk, Karnal.

- MG Panipat**
Rahul Garages LLP
IS Near HUDA Office, Sector 18, G.T Road,
Panipat

- MG Sonipat**
MG Cars Pvt. Ltd.
3S Opposite Ashoka University, Sector 37, GT
Road, Sonipat Haryana

MG MOTOR INDIA SALES AND SERVICE NETWORK

MG Ambala Service

Gitansh Motors Pvt. Ltd.

- 3S 9 KM Stone, Village Khuddi, Jagadhari Road,,
Ambala Cantt, adjoining Elegant Honda,
Ambala

MG Rohtak

Lohchab Autocar Pvt. Ltd.

- IS 4 KM Stone, HSIIDC Industrial Area,
Rohtak-Hisar Road, Rohtak, Haryana 124001

MG Hisar

Gitansh Motors Pvt. Ltd.

- 3S 14.5 Milestone NH65, Chandigarh Road,
Hisar - 125006

MG Gurgaon Metropolis

Cargo Motors(Kutch) Pvt. Ltd.

- EC MGF Metropolis, Sector 28, Gurugram

MG Faridabad

Cargo Motors(Kutch) Pvt. Ltd.

- EC 14/6, Mathura Rd, Pocket B, Sector 27,
Faridabad

MG Gurgaon Service

Cargo Motors(Kutch) Pvt. Ltd.

- 2S Sector 74A, Gurugram - 122001

MG Panipat Service

Rahul Garages LLP

- 2S Behind Radha Swami Satsang Bhawan,
Sector 18, Panipat

MG Rohtak Service

Lohchab Autocar Pvt. Ltd.

- 2S 8 KM Stone, Rohtak-Hisar Road, Village Bahu-
Akbarpur, Rohtak - 124001

MG Faridabad Bodyshop

Cargo Motors(Kutch) Pvt. Ltd.

- 2S 160 A, DLF Industrial Area Ph-1,
Faridabad - 121003

MG Rewari

Cargo Motors(Kutch) Pvt. Ltd.

- Z-Next 2S
Ward No. 5, Opposite Madhusudan School,
Delhi Road, Rewari - 123035

MG Yamuna Nagar

Rahul Garages LLP

- Z-Next 3S
Near Agarsen Chowk, Opp Dimple Cinema,
Jagadhri, Yamuna Nagar - 135001

HIMACHAL PRADESH

MG Mandi Service

Krishna Motor Garage

- 3S Vill.Lunapani PO Bhangrotu The, Balh Distt,
Mandi - 175021

JAMMU & KASHMIR

MG Jammu

Arise Autoz Pvt. Ltd.

- IS Malik Market, Narwal Bypass
Jammu - 180016

MG Jammu Service

Arise Autoz Pvt. Ltd.

- 2S Malik Market, Narwal Bypass
Jammu - 180016

MG Srinagar

Arise Autoz Pvt. Ltd.

- 3S Tangpora Bemina Bypass Near Arise Hyundai,
Srinagar

MG Anantnag

Arise Autoz Pvt. Ltd.

- Z-Next 3S
NH-1A, Uranhall, Anantnag - 192101

MG MOTOR INDIA SALES AND SERVICE NETWORK

JHARKHAND

- MG Ranchi
Singhania Future Pvt. Ltd.**
IS Near Firayalals Pulsar Plaza, Line Tank Rd,
Ranchi - 834001
- MG Jamshedpur
Singhania Future Pvt. Ltd.**
3S Plot No 229 Usha More, Tata Kandra Main
Road, Gamharia Sariakella Kharsawan,
Jamshedpur - 832108
- MG Dhanbad
Singhania Future Pvt. Ltd.**
3S G.T.Road, At Gahira Nirsa Road, Govindpur,
Gahira, Dhanbad - 828109
- MG Dhanbad Dhansar Chowk
Singhania Future Pvt. Ltd.**
EC Beside JCB Showroom, Nr Radha Krishna
Mandir, Dhansar Chowk, Dhanbad - 828106
- MG Ranchi Service
Singhania Future Pvt. Ltd.**
2S NH-33, Chakla, Ormanjhi, Ranchi - 835219

KARNATAKA

- MG Bangalore Electronic City
Jubilant Motorworks Pvt. Ltd.**
IS 195/6/2, Ward No 192, Beratena Agrahara,
Luv Kusha Nagar, Hosur Road,
Bangalore - 560100
- MG Bangalore Kalyan Nagar
Jubilant Motorworks Pvt. Ltd.**
IS Property Bearing No.100/1 And Bearing Site
No.3, Now Come Within The Limites Of
BBMP Khata No.164, Situated At
Chikkathayappa Reddy Layout, First Cross,
Chelekere Village, Outer Ring Road,
Kalyanagar Post Bangalore - 560043
- MG Mysore
Dyuthi Automobiles Pvt. Ltd.**
3S Plot No. 201/1&2, Hunsur Road,
Mysore - 570017
- MG Hubli
Bellad and Company Pvt. Ltd.**
3S Bellad Enterprises Pvt Ltd,Opp NGEF,
Rayapur, PB Road, Hubli - 580025
- MG Mangalore
Jubilant Motorworks Pvt. Ltd.**
3S Survey No. 38, Village, 2 Kuloor - Kavoor Rd,
Kuloor, Padukodi, Mangalore - 575013

MG Bangalore ORR

- Jubilant Motorworks Pvt. Ltd.**
EC Shree Bhuvanewari Vokkaligara Sangha,
Survey No 102- B Narayanapura, ORR,
Bangalore - 560016

MG Bangalore JP Nagar

- Jubilant Motorworks Pvt. Ltd.**
EC BBMP New Municipal No.14, Situated At 100
Feet Road, 4th Phase, J.p. Nagar, BBMP Khata
Bearing Pid No. 57-116-14, Bangalore-560078

MG Bangalore Chord Road

- Jubilant Motorworks Pvt. Ltd.**
EC Site Bearing No. 84 (old No.32), Situated at
20th Main, II-Block, in Rajajinagar Extension,
Ward No.15, BBMP Khata bearing PID
No.15-12-84, Bangalore - 560010

MG Bangalore Electronic City Service Jubilant Motorworks Pvt. Ltd.

- 2S Workshop No.1B, Old Khata No.6/2,
Presently BBMP No. 384/6/2/ 1/B, situated at
Berattena Agrahara, Konapana Agrahara
Grama Panchayat, Electronic City, Hosur Main
Road, Bangalore - 560100

MG Bangalore North Service

- Jubilant Motorworks Pvt. Ltd.**
2S MVIT Workshop- Sy No.32/33, Nellukunte
Village, Jalahalli Hobli, Now Yelahanka Taluk,
MVIT College Road, Hunasemaranahalli Post,
Bangalore - 562157

MG MOTOR INDIA SALES AND SERVICE NETWORK

**MG Bangalore Mahadevpura
(Mechanical) South
Jubilant Motorworks Pvt. Ltd.**
2S No.505 (Old No. 501/7), Puttappa Industrial
Estate, Mahadevpura

**MG Bangalore Central
Jubilant Motorworks Pvt. Ltd.**
1S GF, 40/4, Lavelle Road., Bangalore - 560001

**MG Mysore Road South
Jubilant Motorworks Pvt. Ltd.**
Z-Next 2S
Sri Adiga Automotives, 75, I, Outer Ring Rd,
2nd Phase, Hosakerehalli Layout, Banashankari
3rd Stage, Banashankari, Bengaluru - 560086

**MG Tumkur North
Jubilant Motorworks Pvt. Ltd.**
Z-Next 2S
Arihant Sales & Service, Mahaveer Oil Mill
Compound, Sira Road, Tumkur - 572106

**MG Belgaum
Bellad and Company Pvt. Ltd.**
Z-Next 3S
Shrikrishna Weaving Mill Compound,
Vengurla Road, Vijaynagar, Belgaum - 591108

**MG Hasan
Dyuthi Automobiles Pvt. Ltd.**
Z-Next 3S
54/1, Doddamandiganahally Village, Hasan
City, Hasan - 573210

**MG Gulbarga
Bellad and Company Pvt. Ltd.**
Z-Next 3S
Carnation Car Services, NH 218, Humnabad
Rd, Kapnoor, Gulbarga - 585104

**MG Udupi
Jubilant Motorworks Pvt. Ltd.**
Z-Next 3S
MG Showroom, Opposite to Ganesh Marbals,
9P4R+P99, Nittur, Udupi, Karnataka -576102

KERALA

**MG Cochin
CoastLine Garages India Pvt. Ltd.**
3S XII/801-B, Opp. St. Mary's Chapel, MC Road,
Thellakom P.O., Kottayam - 686630

**MG Calicut
CoastLine Garages India Pvt. Ltd.**
1S Opposite West Hill Post Office, Kannur Road,
West Hill P.O, Calicut - 673005

**MG Thrissur
CoastLine Garages India Pvt. Ltd.**
3S Near Palliakara Toll Plaza, NH-47,
Menmankkiara Chitissery PO
Thrissur - 680301

**MG Trivandrum
Pothen Wheels Private Limited**
1S KJ Square, TC-55/719/1, Kaimanam, Karmana,
Trivandrum - 695040

**MG Trivandrum
Pothen Wheels Private Limited**
3S XII/801-B, Opp. St. Mary's Chapel, MC Road,
Thellakom P.O., Kottayam - 686630

**MG Calicut Service
CoastLine Garages India Pvt. Ltd.**
2S Puthukode Road, Parammal Azhinhilam,
Ramanattukara, Calicut - 673633

**MG Trivandrum Service
Pothen Wheels Private Limited**
2S T.C new 49/461, T.C old 52/459, Thejas
Compound, Vellayani Junction, Nemam P.O,
Trivandrum - 695020

**MG Alappuzha
CoastLine Garages India Pvt. Ltd.**
Z-Next - 2S
8/511-B, Mararikulam, Kalavoor, Opp Valiyar
Kalavoor Temple, Alappuzha - 688522

**MG Kollam
Pothen Wheels Private Limited**
Z-Next - 2S
XII/801-B, Opp. St. Mary's Chapel, MC Road,
Thellakom P.O., Kottayam - 686630

**MG Malappuram
CoastLine Garages India Pvt. Ltd.**
Z-Next - 3S
Aripra Post, Thirurkad, Aripra Schoolpadi,
Malapurram - 679321

MG MOTOR INDIA SALES AND SERVICE NETWORK

MG Palakkad

CoastLine Garages India Pvt. Ltd.

Z-Next - IS

National Highway-544, Near Gov. Medical College Palakkad, Kadamkode, Manapullikavu, Palakkad

MG Palakkad

CoastLine Garages India Pvt. Ltd.

Z-Next - IS

Meen Chatti, Service Road, Kadamkod, Kalmadapam, Palakkad - 678001

MADHYA PRADESH

MG Indore

Hriday Cars Private Limited

IS 1/2-Anoop Nagar, AB Road Indore-452001

MG Bhopal

Hriday Cars Private Limited

IS Near Shiv Mandir, Ahmedpur Kalan Hoshangabad Road, Bhopal 462026

MG Gwalior

Sumedha Vehicles Private Limited

3S Shivpuri Link Road, Village Kedarpur, Gwalior - 474001

MG Jabalpur

Khatwani Motors Pvt. Ltd.

3S 1142, opp. Bhasin arcade, Axis Bank, Prem Nagar, Nagpur Road, Madan Mahal, Jabalpur - 482002

MG Indore Service

Hriday Cars Private Limited

2S Plot no 30/2, Opposite Isuzu Lasudiya Mori Dewas Naka, Near Toll Kata, Indore - 453771

MG Bhopal Service

Hriday Cars Private Limited

2S Plot No-02, Natraj Society-A, Near 11 Mile, Ratanpur, Bhopal - 462047

MG Ratlam

Hriday Cars Private Limited

Z-Next 2S

Sala Khedi, Ratlam-Neemuch Highway-457001

MG Shahdol

Khatwani Motors Pvt. Ltd.

Z-Next 2S

BY Pass Road NH - 78, Burhar Road, Near Old Tata Workshop, Shahdol - 484001

MG Satna

Khatwani Motors Pvt. Ltd.

Z-Next 2S

1168, Kripalpur, Rewa Road, Satna - 485001

MG Chhatarpur

Khatwani Motors Pvt. Ltd.

Z-Next 2S

Ward-32 Near New Panna Naka, Chhatarpur - 471405

MAHARASHTRA

MG Mumbai South

Krishiv Auto Agencies Private Limited

IS Cynergy IT Park, Near Maratha Udyog Bhavan, Appa Saheb Marathe Marg, Prabhadevi, Mumbai - 400025

MG Mumbai West

Krishiv Auto Agencies Private Limited

3S CTS 227, Service Road, Near Junction of JVL & Western Express Highway, Gupha Tekdi, Opp. Balsaheb Thackrey Hospital, Jogeshwari (East), Mumbai - 400063

MG Thane

Tejpal Motors Pvt. Ltd.

IS Shop no 16, Dosti Imperia, Ghodbunder Road, Thane West - 400610

MG Pune Wakad

B.U Bhandari Auto Pvt. Ltd.

3S Survey no 142, Hissa no 1+2/5, Wakad, Mumbai Bangalore Highway, Pune - 411057

MG Nagpur

Nangia Cars Pvt. Ltd.

3S 33B 1/4 Hinghna MIDC Opp Nangia Speciality Hospital Nagpur - 440028

MG MOTOR INDIA SALES AND SERVICE NETWORK

- MG Kolhapur**
Unique Automobiles Maharashtra Pvt. Ltd.
 IS S.No 592, H.No 4481 1st Stop MIDC
 Shirolip) Tal-Hatkanangale,
 Kolhapur - 416122
- MG Nasik**
Jitendra Wheels (N) Pvt. Ltd.
 IS B-88 MIDC Ambad, Mumbai Agra Highway,
 Next to Hotel Gateway, Nashik- 422010
- MG Aurangabad**
Dhoot Motors Autotech Pvt. Ltd.
 IS ABC Complex, Adalat Road,
 Aurangabad - 431005
- MG Pune Central**
B.U Bhandari Auto Pvt. Ltd.
 3S 2422, General Thimayya Road, East Street
 Camp, J William & Co, Pune - 411001
- MG Solapur**
Gandhi Cars
 3S 75/5/1, Bale, Pune Road, Solapur - 413255
- MG Mumbai Malad**
Krishiv Auto Agencies Private Limited
 EC Shakti Premises, Near Inorbit Mall, New Link
 Road, Ram Nagar, Malad (West) Opp. Cloud
 Nine Hospital, Mumbai - 400064
- MG Navi Mumbai**
Tejpal Motors Pvt. Ltd.
 EC Old Mahindra Showroom, Next to AutoBahn
 VW Showroom - 400706
- MG Thane Service**
Tejpal Motors Pvt. Ltd.
 2S Western Extrusion Industries, Near Capital
 Hotel, Thane West - 400606
- MG Kolhapur Service**
Unique Automobiles Maharashtra Pvt. Ltd.
 2S C/O-Choughle Machines Pvt .Ltd., A- 7/18,
 MIDC, Shirolip, Kolhapur - 416122
- MG Nasik Service**
Jitendra Wheels (N) Pvt. Ltd.
 2S P-11/2, Ambad MIDC, near Volksawagen
 Showroom, opp Lokmat office, Mumbai Agra
 Highway, Nasik - 422010
- MG Aurangabad Service**
Dhoot Motors Autotech Pvt. Ltd.
 2S Adalat Road, Next to High Court,
 Aurangabad - 431005
- MG Malad Service**
Krishiv Auto Agencies Private Limited
 2S CTS 301 of Village Valnai Near Mith Chowky
 Link Road, Malad, Mumbai - 400097
- MG Navi Mumbai Service (Mechanical)**
Tejpal Motors Pvt. Ltd.
 2S Plot No 238, MIDC, TTC Industrial Area
 Vane Village, Navi Mumbai - 400607
- MG South Mumbai Service (Mechanical)**
Krishiv Auto Agencies Private Limited
 2S MG South, Eastern Metle Works, Dattaram
 Lad Marg, Near Sita Sadan, Kalachowki,
 Byculla East - 400033
- MG Navi Mumbai Chembur**
Tejpal Motors Pvt. Ltd.
 IS Natraj Compound, Dr. C. G. Road,
 Near Shivaji Maharaj Chowk, Chembur,
 Mumbai - 400074
- MG Sangli**
Unique Automobiles Maharashtra Pvt. Ltd.
 Z-Next 2S
 C.S.No. 290 A/2, Vakhar Bhag, Sangli - 416416
- MG Jalgaon**
Jitendra Wheels (N) Pvt. Ltd.
 Z-Next 2S
 C6/opp Vasumitra Hotel, Raymond Chowk,
 MIDC Jalgaon - 425003

MG MOTOR INDIA SALES AND SERVICE NETWORK

MG Shirdi

Jitendra Wheels (N) Pvt. Ltd.

Z-Next 2S

Shri Ganesh Auto Scan, Nagar- Manmad Road,
At post: Sakuri, Taluka Rahata, Dist:
Ahmednagar - 423107

MG Baramati

B.U Bhandari Auto Pvt. Ltd.

Z-Next 3S

Near by Dhone Ford, Nevse Basti, Morgaon
Road, Baramati - 413102

MG Ahmednagar

Jitendra Wheels (N) Pvt. Ltd.

Z-Next 3S

Nagar Manmad Road, MIDC Near Gajanan
Colony Chowk, Nav Nagapur, Ahmednagar

MG Chandrapur

Nangia Cars Pvt. Ltd.

Z-Next 3S

MG Chandrapur, Plot No. X-12, Chandrapur
(Tadali) Growth Centre, Chandrapur

MG Nanded

Dhoot Motors Autotech Pvt. Ltd.

Z-Next 3S

House No 542-1, Opposite Spinning Mill,
near Sambhaji Sut Girni, Wajegaon,
Nanded - 431602

MG Satara

Unique Automobiles Maharashtra Pvt. Ltd.

Z-Next 3S

289/2, Wadhe-Satara Road, Near Pooja Petrol
Pump, Wadhe - 415011

MG Amravati

Nangia Cars Pvt. Ltd.

Z-Next 3S

Badnera Road, Opposite D Mart, Guruchhaya
Colony, Gopal Nagar, Amravati,
Maharashtra - 444607

MG Latur

Dhoot Motors Autotech Pvt. Ltd.

Z-Next 3S

Sree Nagar, Latur MIDC - 413531

MG Dhule

Jitendra Wheels (N) Pvt. Ltd.

Z-Next 3S

P-62, Advhan MIDC, behind Botel Manas-
424311

ODISHA

MG Bhubaneshwar

Empreo Wheels Private Limited

3S

Plot No. 86/88, Near Apex Institute of
Technology & Management, Pahala, NH-16,
Bhubaneswar - 752101

MG Angul

Empreo Wheels Private Limited

Z-Next 1S

NH 55 Telco Chowk Nuahata, Banarpal,
Angul - 759128

MG Angul

Empreo Wheels Private Limited

Z-Next 2S

NH 55 Telco Chowk Nuahata, Banarpal,
Angul - 759128

MG Sambalpur

Empreo Wheels Private Limited

Z-Next 3S

Plot No. 231 C/o- Samal Equip At-Pardhiapali
Po-Sankarma, Sambalpur

MG Balasore

Empreo Wheels Private Limited

Z-Next 3S

Plot No-914/1175/1565 C/o Samal Equip inf-
Morden Engineering College, Nh-5
Khannager, Balasore

MG MOTOR INDIA SALES AND SERVICE NETWORK

PUDUCHERRY

- MG Puducherry**
FPL Vehicles Pvt. Ltd.
3S No.1 Cuddalore, Puducherry ECR Main Road,
Ariyankuppam, Puducherry - 605007

PUNJAB

- MG Chandigarh Tricity**
Krishna Motor Garage
1S Business Block, Elante Mall -178, MW Area,
Industrial Area Phase I, Chandigarh - 160002
- MG Ludhiana**
Gitansh Motors Pvt. Ltd.
3S GT Road Jugiana, Adjoining Indian Oil Petrol
Pump, Ludhiana - 141010
- MG Jalandhar**
Cargo Motors (Kutch) Pvt. Ltd.
3S BSF Chowk, G.T. Road, Jalandhar - 144001
- MG Patiala**
Krishna Motor Garage
3S Near Casba Resort, Rajpura Patiala Road,
Patiala - 147001
- MG Amritsar**
Cargo Motors (Kutch) Pvt. Ltd.
1S Khasra No.-1248, VPO -Daburji, Near Golden
Gate, GT Road, Amritsar - 143022

MG Mohali

- Krishna Motor Garage**
3S Plot no 3, Janta Industrial Estate, Sector 82,
SAS Nagar, Mohali - 160082

MG Amritsar Service

- Cargo Motors (Kutch) Pvt. Ltd.**
2S Opp Bhagat Ford Service, Daburjee, Rampura
Road, Amritsar - 143002

MG Hoshiarpur

- Cargo Motors (Kutch) Pvt. Ltd.**
Z-Next 2S
Bharvain Road Near Ambay Velly,
Hoshiarpur - 146001

MG Nawanshahr

- Cargo Motors (Kutch) Pvt. Ltd.**
Z-Next 2S
Opp Civil Hospital, Chandigarh Road, Bill,
Zethu Mazra Nawanshahr - 144514

MG Bhatinda

- Gitansh Motors Pvt. Ltd.**
Z-Next 3S
OPP. - IVY Hospital Bhai Mati Das Nagar
Bathinda Mansa Road, Bathinda - 151001

RAJASTHAN

MG Jaipur

- Tonk Road GPS Automobiles Pvt. Ltd.**
1S Plot No. 2& 3/4, Choudhary Charan Singh
Colony, Tonk Road, Jaipur - 302029

MG Jodhpur

- Ganpati Four Wheels Pvt. Ltd.**
3S Plot No - 18, Opp. Saras Dairy, Heavy
Industrial Area, Jodhpur-342003

MG Kota

- Om Automotors Pvt. Ltd.**
1S Om Metal Infra projects Ltd. Spl 1(A) IPIA
Jhalawar Road, Near Anantpura Chauraha,
Kota - 324005

MG Ajmer

- GPS Automobiles Pvt. Ltd.**
3s Khasra No. 45,46,47, Ajmer By Pass NH 8
Badliya Chouraha, Near Nareli Jain Temple,
Ajmer - 305024

MG Jaipur Ajmer Road

- GPS Automobiles Pvt. Ltd.**
EC Near Bajaj Capital, G-3, Anukampa Tower,
Church Road (M.I. Road), Gopalbari,
Jaipur - 302001

MG MOTOR INDIA SALES AND SERVICE NETWORK

MG Jaipur Service

GPS Automobiles Pvt. Ltd.

- 2S G-22I Sitapura Industrial Area, Sitapura,
Jaipur - 302022

MG Kota Service

Om Automotors Pvt. Ltd.

- 2S Om Metal Infraprojects Ltd, Plot No.A 21-22
Industrial Area Estate, Kota - 324005

MG Sikar

GPS Automobiles Pvt. Ltd.

- Z-Next 2S
Near R.T.O, Jaipur - Jhunjhunu Bypass,
Sikar - 332001

MG Sri Ganganagar

Ganpati Four Wheels Pvt. Ltd

- Z-Next 2S
Chak 3 ML, Suratgarh Rd,
Hanumangarh - 335001

MG Bhilwara

PPS Motors Private Limited

- Z-Next 2S
E-3I Madav Nagar, Bhilwara - 311001

MG Udaipur

PPS Motors Private Limited

- 3S CP-6/CP-7, Madri Industrial Area - 313001

TAMIL NADU

MG Chennai Anasalai

FPL Vehicles Pvt. Ltd.

- 1S NO. 824/2, Annasali Nandnam,
Chennai - 600035

MG Coimbatore

PPS Motors Private Limited

- 3S No-138, Avinashi Road, Chinniyampalayam,
Coimbatore - 641062

MG Madurai

PPS Motors Private Limited

- 3S Shed No. D-23, Nilaiyur First Bit, Uchapatti
Village, Thirumangalam, Madurai - 625402

MG Salem

PPS Motors Private Limited

- 3S S.NO.151/1, N.H.44, Bangalore Highway,
Mamangam Salem

MG Trichy

PPS Motors Private Limited

- 3S 31/3A, D/NO. Dindugal Mainroad, Ramji
Nagar, Punganur

MG Chennai OMR

FPL Vehicles Pvt. Ltd.

- EC No 4, Perungudi Industrial Estate, Perungudi,
Old Mahabalipuram Road, Chennai - 600097

MG Chennai Service

FPL Vehicles Pvt. Ltd.

- 2S Developed Plot No. 5, South Phase,
Thiru Vi. Ka. Industrial Estate, Guindy,
Chennai - 600032

MG Ambattur

FPL Vehicles Pvt. Ltd.

- 1S Sp 98, Southern Avenue Road, Ambattur
Industrial Estate, Chennai - 600058

MG Vellore

FPL Vehicles Pvt. Ltd.

- Z-Next 3S
33/5A1, Chennai Bangalore Highway,
Perumugai, Vellore - 632009

MG Thanjavur

PPS Motors Private Limited

- Z-Next 3S
SY. No:133/4, New SY. No:133/4A1A,
Papammal Pannerselvam Nagar,
Nanjikottaivattam Village

MG Erode

PPS Motors Private Limited

- Z-Next 3S
1/320, Veppampalayam, Pichandampalayam,
Perundururai Main Road, Kadirampatti Post,
Erode

MG MOTOR INDIA SALES AND SERVICE NETWORK

TELANGANA

- MG Hyderabad Banjara Hills Raam4Wheelers LLP**
IS 8-2-120/86/10,10A,11B,11C and 11D, Opp: Hotel Park Hyatt, Road Number 2, Banjara Hills, Hyderabad - 500033
- MG Hyderabad Kondapur Raam4Wheelers LLP**
3S Plot no.192,Serilingampally, Botanical Garden Road, Camelot Place, Gouthami Colony, Kondapur, Hyderabad - 500084
- MG Hyderabad Gachibowli RAAM4WHEELERS LLP**
EC 7-56/19, Dargah Road, Radhe Nagar, GachiBowli, Rai Durg - 500035
- MG Hyderabad Service RAAM4WHEELERS LLP**
2S H. No. 7-8-188/3, Gautam Nagar, Balanagar, Secunderabad - 500011
- MG Attapur Raam4Wheelers LLP**
2S Plot No - 28, 29, Door no. 2-5-28, Survey No 30, Upperpally Village, Rajendra Nagar Mandal, Hyderabad

MG Nizamabad RAAM4WHEELERS LLP

- Z-Next 2S
H.No.1-1-7/D/1A/10 Near Mannuru Kapur Kalayana Madam, Pragathi Nagar, Nizamabad - 503001

MG Khammam RAAM4WHEELERS LLP

- Z-Next 2S
Junction H NO 10-6, 184/5, Bypass, Raparthi Nagar, Khammam - 507002

MG Mahabubnagar RAAM4WHEELERS LLP

- Z-Next 2S
Plot No. 1&3, Survey No.3A, Opp: SVS Medical College, Near Chaitanya Central School, Yenugonda, Mahaboobnagar - 509001

MG Warangal Raam4Wheelers LLP

- Z-Next 1S
H.No: 23-6-201/6/1, Madatha Towers Dwaraka Nagar, Hunter Road, Hanamkonda, Warangal Urban - 506002

MG Warangal Raam4Wheelers LLP

- Z-Next 2S
12-8-301/10 Bondivagu, Beside Tafe Showroom, Hunter Road, Near Greenwood, Hanamkonda, Warangal - 506001

MG Karimnagar Raam4Wheelers LLP

- Z-Next 3S
Near Kaloji Statue, Adjacent To Mahaveer Marble & Granites, Jagital Road, Rekurthi

UTTAR PRADESH

MG Noida Crystal Autocars Private Limited

- 3S D-2, Sector 8, Noida - 201301

MG Lucknow Chinhat Beeaar Autowheels India Pvt. Ltd.

- 3S Milestone No. 111, Faizabad Road, Chinhat, Lucknow - 227105

MG Kanpur Socmo Cars Private Limited

- 1S 15/63, Rudra House, Civil Lines, Kanpur - 208001

MG Agra NRL Cars Pvt. Ltd.

- 3S 404, Nagla Padi, Near Arvind Hyundai 282005

MG Varanasi Puneet Car Sales Private Limited

- 1S Andhrapull, Chaukaghat, Varanasi - 221002

MG MOTOR INDIA SALES AND SERVICE NETWORK

- MG Bareilly**
Keshav Raj Automobiles Private Limited
 3S 4.5 KM Rampur Road, C. B Ganj
 Bareilly-243001
- MG Prayagraj**
Puneet Car Sales Private Limited
 3S Varanasi, Allahabad Road, Andanva, Jhusi
 Khona - 211019
- MG Gorakhpur**
Beeaar Autowheels India Pvt. Ltd.
 IS Vrindavan Towers, Medical College Road,
 Basharatpur, Gorakhpur
- MG Jhansi**
Socmo Motors LLP
 3S Society Trucking- Bharat Benz(old State Bank
 Building), Digara, Kanpur Jhansi Road,
 Jhansi - 208001
- MG Ghaziabad**
Crystal Autocars Private Limited
 EC Block G, Patel Nagar 3, Ghaziabad - 201003
- MG Lucknow Hazratganj**
Beeaar Autowheels India Pvt. Ltd.
 EC 10 Ashok Marg, Opposite GST Bhawan,
 Hazratganj, Lucknow - 226001
- MG Kanpur Service**
Socmo Cars Private Limited
 2S 12/483, Macrobertganj, Kanpur - 208002
- MG Varanasi Service**
Puneet Car Sales Private Limited
 2S Grand Trunk Rd, Parao, Near Ambition
 Institute of Technology, Varanasi - 221002
- MG Gorakhpur Service**
Beeaar Autowheels India Pvt. Ltd.
 2S BL-7, Sector 15, GIDA, Sahjanwa
- MG Ghaziabad Service (Mechanical)**
Crystal Autocars Private Limited
 2S Khasra No. 1336-1337, Mainapur Industrial
 Area, Meerut Road, Ghaziabad
- MG Lucknow Transport Nagar Service (Mechanical)**
Beeaar Autowheels India Pvt. Ltd.
 2S E-28/49B, Near Parking no. 9, Transport
 Nagar, Lucknow
- MG Lucknow South**
Beeaar Autowheels India Pvt. Ltd.
 IS Shop no- 001, GF, JB Metro heights, Kanpur
 Road, Lucknow
- MG Bulandshahr**
Crystal Autocars Private Limited
 Z-Next 2S
 Chandpur Village, Near MMR Mall, GT Rd,
 Chandpur, Bulandshahr - 203001
- MG Mathura**
NRL Cars Pvt. Ltd.
 Z-Next 2S
 In front of Mathura Refinery Main Gate,
 Mathura Bypass, Mathura - 281006
- MG Sultanpur**
Beeaar Autowheels India Pvt. Ltd.
 Z-Next 3S
 Dream Nissan, 525, near Jail Gate, opp. Ganga
 Garden, Gabhariya, Sultanpur - 228001
- MG Moradabad**
Keshav Raj Automobiles Private Limited
 Z-Next 3S
 Bhatawali, Kanth Rd, Opp. Hanuman Mandir,
 next to Arjun Vasui Hyundai Service,
 Moradabad
- MG Aligarh**
NRL Cars Pvt. Ltd.
 Z-Next 3S
 Old Niharika JP Force Showroom, Meharwal
 GT Road, Near Meharwal Mod, Aligarh
- MG Meerut**
Grand Vehicles (P) Limited
 IS Abhikarm, Civil Lines, Meerut - 250001

MG MOTOR INDIA SALES AND SERVICE NETWORK

MG Meerut Service Grand Vehicles (P) Limited

- 2S CP 4, Shradhapuri Ph. 2, Kankarkhera, NH 58
Bypass, Meerut - 250001

UTTARAKHAND

MG Dehradun Grand Vehicles (P) Limited

- 3S Saharanpur Road, MahobewalaChowk,
Dehradun - 248002

MG Haldwani Keshav Raj Automobiles Private Limited

- 3S Siddharth City Dewalchaur bandobasti 5KM
Rampur Road, Jeetpur Negi, Haldwani

MG Roorkee Grand Vehicles (P) Limited

- Z-Next 3S
NH 58, Rehmadpur, Uttarakhand -247667

WEST BENGAL

MG Kolkata South Auto Hi-Tech Pvt. Ltd.

- 1S 97A Southern Avenue, Kolkata 700029

MG Siliguri Siliguri Auto Works Pvt. Ltd.

- 3S 2, 1/2 Mile, Sevoke Road, Siliguri

MG Kolkata North Auto Hi-Tech Pvt. Ltd.

- EC EcoCentre Ambuja Neotia, EM Block,
Sector V, Salt Lake City, Kolkata - 700091

MG Kolkata Service Auto Hi-Tech Pvt. Ltd.

- 2S 34A C.N. Roy Road, Kolkata - 700029

MG Durgapur Auto Hi-Tech Pvt. Ltd.

- Z-Next 2S
Mozumder Automobiles, Banskopa (Near L&T
More) Bamunara, Durgapur - 713212

MG Gangtok Siliguri Auto Works Pvt. Ltd.

- Z-Next 3S
MG Gangtok, Khangsarpa Building, Below
Tadong School, Tadong Bazaar, Gangtok,
East Sikkim

VEHICLE RECORD SHEET

MODEL																
CHASSIS NO.																
ENGINE NO.																
KEY NO.																
DATE OF DELIVERY																
MILEAGE (KM)																
BATTERY	MAKE					SR NO./ BATCH CODE										
TYRE	TYRE LOCATION			FR RH <input type="checkbox"/>		FR LH <input type="checkbox"/>		RR RH <input type="checkbox"/>		RR LH <input type="checkbox"/>						
	MAKE					BATCH NUMBER										

OWNER'S NAME & ADDRESS:

ADDRESS OF SELLING DEALER

Showroom:
Workshop:

For any feedback, please call **Toll free No: 1800 100 6464**

www.mgmotor.co.in
1800 100 6464

MG Motor India Pvt. Ltd.

All information, illustrations and specifications contained in this Owner's Manual are based on the latest production information available at the time of publication. The right is reserved to make changes at any time without notice.

Version: 02-12/2020/1500

