

Downloaded From

 **Drive Inside**
car shopping made easy [.com](http://driveinside.com)



CAR BROCHURE

Maruti  

ALL NEW
ESTILO

Take a fresh view of life.



MARUTI  SUZUKI
Way of Life!

Take a fresh view of life .

Life is a journey. Imagine discovering something new each day. By taking new routes that enliven you. The all new Estilo brings to this journey a touch of class and comfort. After all, it is a complete car which has been designed keeping you in mind, so that you keep discovering life afresh each day. Go ahead, experience life in a fresh new way.



A fresh style.

With a bold new styling, aerodynamic contours and smooth curves, the all new Estilo is a perfect combination of sturdiness and class. The rich chrome front grill, creased hood, dynamically designed head lamps and sculpted fog lamps reflect your taste for finesse and style. It is crafted to bring freshness to your daily drive.



Dynamic Head Lamps that add class to the bold styling.



Sculpted Fog Lamps to add finesse to the front.

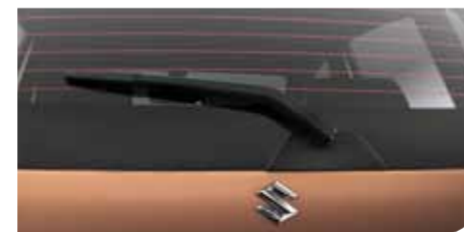

Rear Wiper Washer to ensure you get a fresh clear rear view.

- Body Coloured Door Handles & ORVM.
- Stylish Wheel Caps.
- Body Side Moldings.

Fresh elegant interiors.

The elegant interiors of the all new Estilo are a fine blend of comfort and sophistication. Just the way you like it. Dual-tone dashboard (Chocolate brown and Beige colour), ergonomically designed seats, roomy interiors with ample leg room and a rear luggage shelf make it chic and spacious. Now make every drive a rejuvenating experience.



Enjoy more room and storage space with Foldable Rear Seats.



Illuminated Instrument Cluster with Silver Lining that adds to the elegance.



Four Power Windows to let you enjoy the view and the wind at the push of a button.

- Colour coordinated Seat Fabric.
- AC Vents with Chrome Finish Rings.
- Adjustable Head Rests.
- Remote Fuel Lid Opener.



Rear Parcel Tray that gives you more convenience and easy storage.



Newly designed electronically adjustable ORVMs. Now you can adjust the mirrors from the inside at the touch of a button.

Experience power afresh.

With an all aluminum K Series Engine, the all new Estilo lets you experience power in a fresh new way. The pleasure of daily driving is all yours with a Detent Pin Transmission Technology and Cable system that offer smooth gear shifting and a great handling. Take the all new Estilo for an exhilarating spin, take your driving comfort to a whole new level.

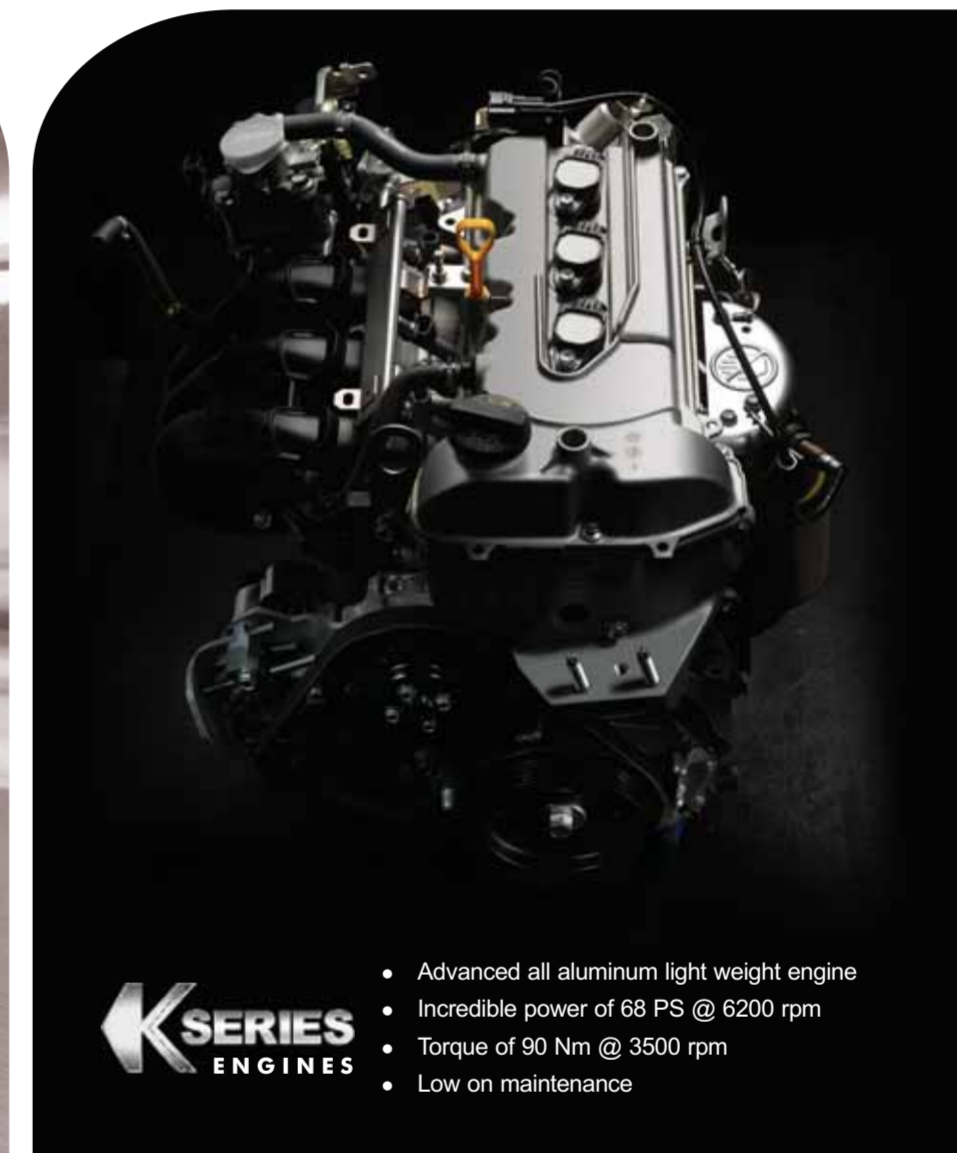

Cable type gear shift mechanism with DETENT PIN TECHNOLOGY (DPT) for smooth and precise gear shifting experience.

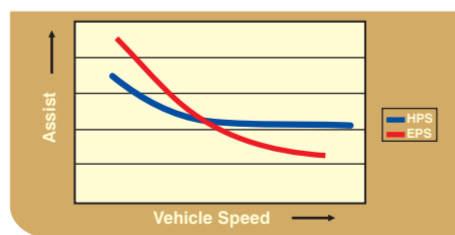

Electronic Power Assisted Steering that gives better handling, more mileage and is low on maintenance.



Low Turning Radius to give you better maneuverability in those crowded city streets.

- BS IV Compliant.
- High Power To Weight Ratio for Better Pick-up.
- Amazing Fuel-Efficiency.

18.2*
km/l

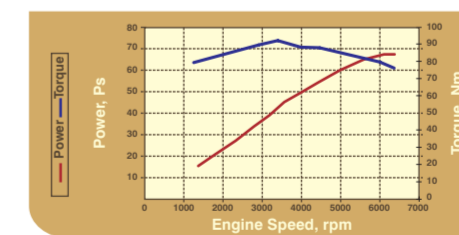

Now experience incredible power and amazing mileage. Let the K Series Engine power your drives like never before.

*Test results of rule 115 of CMVR

A safer fresh drive.

With a set of advanced safety features, the all new Estilo is designed to let you enjoy your drive without a worry. Equipped with ABS, Airbags, TESS and much more, it ensures that you and your loved ones are safe and secure. Go on those drives and have safe journeys one after the other.

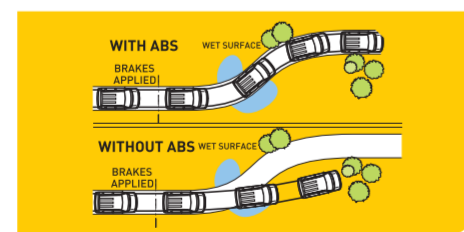

ABS* Technology that gives you better control and offers superior handling.



Airbags* to add more safety to your drives.



TESS - TOTAL EFFECTIVE STRENGTH STRUCTURE. To enhance the occupants' safety further.

*Optional in VXI

■ Headlamp Leveler.



Integrated key with Central Locking to give you a fresh level of security.



Anti-Theft Security Alarm to keep your car secure where ever you go.

Many colours of a fresh drive.

Colours give life its freshness and vigour. Not to mention they define your personality too. That is why, the all new Estilo comes in a wide range of fresh bold colours for you to choose from. Select your colour and make a fresh personality statement.

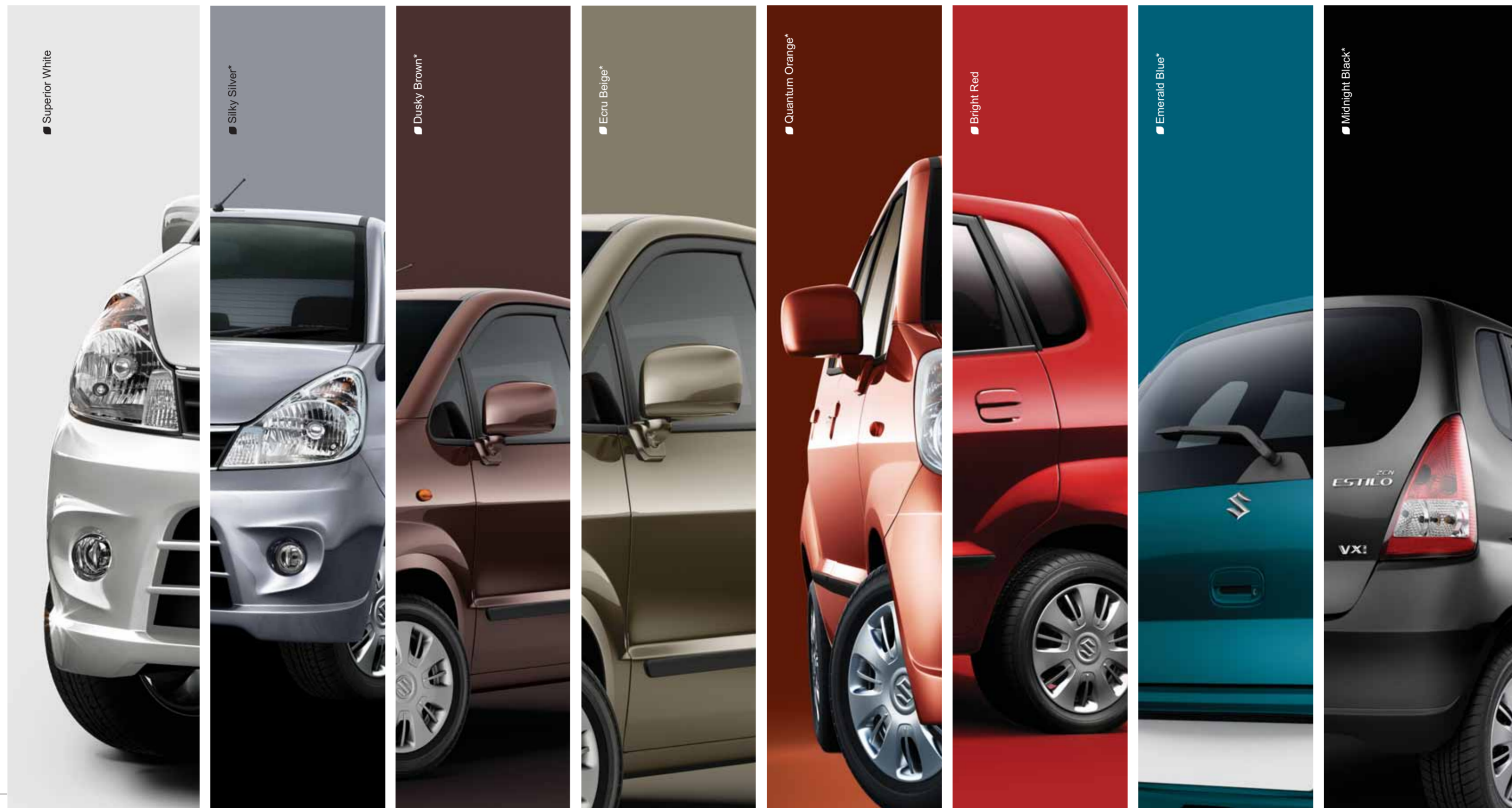

A fresh drive called life.

It's time to take a break from routines and rediscover life. To leave behind the mundane and go by what your heart desires. By looking at life afresh. By doing things in a new way. The all new Estilo comes with a powerful K Series Engine, fresh and elegant interiors and a bold design. To make each drive a fresh experience. Go ahead, experience a fresh new drive. And a fresh new life.





Zen Estilo Specification and Feature List

SPECIFICATION IN MM	
Length	3600
Width	1475 (LX/LXi), 1495 (VXi)
Height	1595
Wheel Base	2360
Tread, Front	1295
Tread, Rear	1290
Turning Radius	4.6 m
Seating capacity	5
Ground clearance	165 mm
Max power (PS / rpm)	68 PS @ 6200 rpm
Max. Torque (Nm / rpm)	90 Nm @ 3500 rpm
Engine	K10B
Engine capacity	998 cc
Engine Type	3 cyl
Transmission	5 MT
Drive	2 WD
Clutch Type	Dry, single disc, diaphragm type
Kerb Weight (kg)	845 (LX, LXi), 865 (VXi)
GVW (kg)	1275
Tyre Size (Tubeless)	145 / 70 R13 (LX, LXi), 155/65 R13 (VXi)
Fuel tank capacity (l)	35
Front Brake	Ventilated Disc
Rear Brake	Drum
Transmission Type	Manual 5 speed
Suspension type	Fr: McPherson strut with Torsion type roll control device. Rr: Coil spring, Gas filled shock absorbers with three link rigid and isolated trailing arm
Power steering	Electronic Power steering (EPS) (Lxi & Vxi)

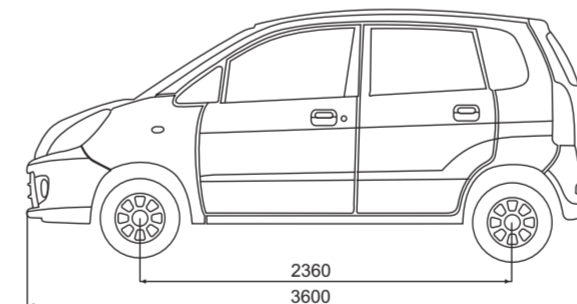
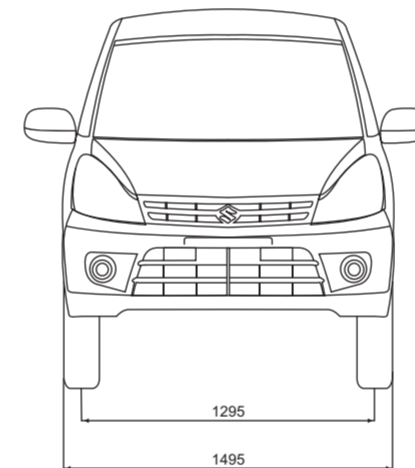
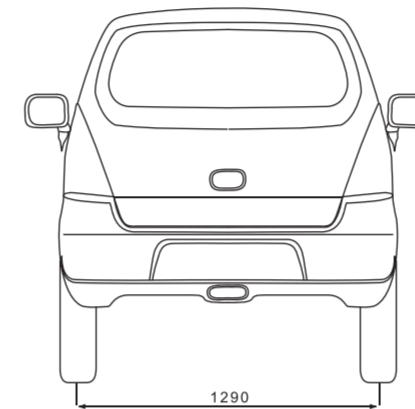

FEATURES	LX	LXi	VXi
SAFETY & SECURITY			
1 SRS Airbag (Driver Side)**			✓
2 ABS**			✓
3 Side Door Beams	✓	✓	✓
4 High Mount Stop Lamp	✓	✓	✓
5 Child Lock (Rear Door)	✓	✓	✓
6 Front Wiper (2 speed + intermittent)	✓	✓	✓
7 Back Door Defogger			✓
8 Front Fog Lamps			✓
9 Rear Fog Lamps			✓
10 Rear Window Wiper & Washer			✓
11 iCATS	✓	✓	✓
12 Steering Lock	✓	✓	✓
13 Security System			✓
EXTERIOR			
1 Body Colored Bumper		✓	✓
2 Body-Side Molding			✓
3 Wheel Cap	CTR	CTR	FULL
4 Black Out Film			✓
5 Body Colored Outside Door Mirrors			✓
6 Body Colored Outside Door Handle		(Back Door Only)	✓
7 Antenna	✓	✓	✓
INTERIOR			
1 Front Seat Adjustable Head Restraint	✓	✓	✓
2 Rear Seat Adjustable Head Headrests	✓	✓	✓
3 Front Seat Back Pocket (Driver's Seat)			✓
4 Rear Seat	Bench	Bench	Bench
5 Floor Carpet	✓	✓	✓
6 Cup Holders	Fr 2+Rr 1	Fr 2+Rr 1	Fr 2+Rr 1
7 Rear Luggage Shelf			✓
8 Seat Fabric	New Standard Fabric	New Standard Fabric	New Luxury Fabric
IP / CONSOLE			
1 Centre Console with cup holder	✓	✓	✓
2 IP Pocket	✓	✓	✓
3 Tachometer			✓
4 Lights - off & Key Reminder Chime			✓
5 Accessory Socket			✓
6 Ashtray	✓	✓	✓
7 Fuel level indicator - Digital Display	✓	✓	✓
8 Steering Wheel	(3 SP)	(3 SP)	(3 SP)
COMFORT & CONVENIENCE			
1 Power Windows		FR	FR/RR
2 Power Steering		✓	✓
3 Front Door Pocket	✓	✓	✓
4 Remote Keyless Entry System (Integrated with key)			✓
5 ORVM (R/L)	Paddle type	Paddle type	Internally adjustable electrical type
6 AC	✓	✓	✓
7 Backdoor Opener	Key	Power Lock + Key	Power Lock + Key
8 Remote Fuel Lid Opener	✓	✓	✓
9 Sun Visor with Ticket Holder	✓	✓	✓
10 Vanity Mirror (Sun Visor)			(Co-driver)
11 Grip Assistant (3 nos.)	✓	✓	✓
12 Co-driver side front door lock	✓	✓	✓
13 Speaker provision	✓	✓	✓
14 Central Door Locks	✓	✓	✓

**Optional in VXi

www.marutisuzukiestilo.com

Dealer stamp



Maruti Suzuki India Limited reserves the rights to change without notice prices, colours, equipment specifications and models and also to discontinue models. Accessories and features shown in the pictures may not be part of the standard equipment and will differ according to the variants. For variant - specific features, refer to the equipments list. Colours shown may vary from actual body colours due to printing on paper. 712 sales points, 2783 service centers & 1325 cities covered by service network and over 15058 trained sales personnel as on 1st August 2009. MARUTI SUZUKI INDIA LTD., Plot No. 1, Nelson Mandela Road, Vasant Kunj, New Delhi - 110070, India.