

NEXA

S-CROSS

## OWNER'S MANUAL & SERVICE BOOKLET

• Keep With Vehicle At All Times • Contains Important Information On Safety, Operation & Maintenance

Part No. 99011M64M00-74E  
July, 2015

ENG

This Owner Manual & Service Booklet applies to the S-CROSS series  
produced by MARUTI SUZUKI INDIA LIMITED

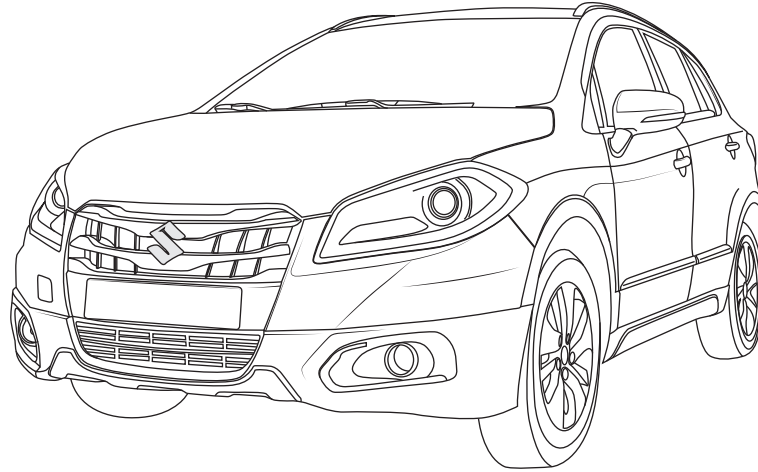

**Pankaj Narula**

Executive Director (Service)



*Dear Sir/ Madam,*

Thank you for choosing a Maruti Suzuki vehicle.

I hope our dealership team took good care while delivering the vehicle to you.

Your vehicle is equipped with state-of-the-art technologies. To get the best performance from your vehicle (and ensure it is trouble-free), kindly get your vehicle serviced periodically, as per the maintenance schedule in your Owner's Manual. Please make sure the service is done at a authorised Maruti Suzuki workshop for best results.

For any accessories that you wish to fit on to your vehicle, please contact any of our authorised Maruti Suzuki workshop for assistance. Kindly appreciate that any tampering of wiring harness to fit accessories may cause the vehicle to malfunction.

Thank you once again for choosing a Maruti Suzuki vehicle.

I wish you many years of safe and happy driving.

*Yours sincerely,*

A handwritten signature in black ink, appearing to read 'Pankaj Narula'.

**(Pankaj Narula)**

**MARUTI SUZUKI INDIA LIMITED**

Palam Gurgaon Road

Gurgaon - 122015

[www.marutisuzuki.com](http://www.marutisuzuki.com)



# “WARNING”



Vehicle may **break-down**, meet with an **accident** or **catch fire** due to

1. Installation of
  - High wattage bulbs
  - Non genuine lamps / horns
  - Modified suspension / wheels
  - Non genuine parts / accessories etc.
2. Retrofitment of LPG / CNG fuel systems/kits.
3. Usage of domestic LPG.
4. Short circuiting due to tampering of wiring harness.

CAUTION: DO NOT STORE OR CARRY INFLAMMABLE MATERIALS IN THE VEHICLE.



Avoid driving into or starting the vehicle in a heavily water logged area. Vehicle may **break-down** or engine may fail due to

1. Water entry into the engine.
2. Short circuiting of the electrical systems.

If the vehicle is stuck in deep water, **do not start / crank the vehicle until the level of water drops below the level of exhaust pipe.**

NOTE:

IF THE VEHICLE IS SUBMERGED IN WATER, REPORT TO THE NEAREST AUTHORISED MARUTI SUZUKI WORKSHOP.

# “CAUTION”

1. Retro-fitment of LPG/CNG kit may deteriorate vehicle performance, reduce engine & engine related component's life and also warranty will be null and void for such vehicles.
2. Do not use domestic LPG/LPG cylinder for your factory fitted LPG vehicles.
3. Usage of domestic LPG for running vehicles is prohibited as per law.
4. Do not remove company fitted LPG/CNG kit to install some other kit. It may affect vehicle performance and may cause fire.
5. Drive slowly on wet roads. Tires may slip while braking at higher speeds due to aquaplaning. (reduced contact area between tire and road due to presence of water)
6. Do not leave engine running in garages or confined areas, with passengers inside. This may result in accumulation of carbon-mono-oxide in cabin and may lead to suffocation or breathing problems.
7. Do not park vehicle on dry leaves or grass. This may lead to fire due to hot catalytic converter, igniting the dry leaves/grass.
8. If the vehicle is equipped with CNG/LPG, ensure availability of fire extinguisher in the vehicle all the time.
9. Always wear seat belt at all the times.
10. Do not use mobile phone while driving.
11. Avoid Smoking in the car, live bud thrown in car may cause fire.
12. Do not put any body part under the vehicle when it is supported on a Jack.
13. Do not use non-genuine accessories in your vehicle.
14. Do not fit accessories from unauthorized workshops/sources.
15. Usage of non-approved electrical accessories in your vehicle may result in spark, fire or personal injury.

---

## FOREWORD

This manual is an essential part of your vehicle and should remain with the vehicle when resold or otherwise transferred to a new owner or operator. Please read this manual carefully before operating your new vehicle and review the manual from time to time. It contains important information on safety, operation and maintenance. You are invited to avail the three Free Inspection Services as described in the manual. Three free inspection coupons are attached to this manual. Please show this manual to your while you take your vehicle for any Service.

To prolong the life of your vehicle and reduce maintenance cost, the periodic maintenance must be carried out according to "PERIODIC MAINTENANCE SCHEDULE" described in "INSPECTION AND MAINTENANCE" section of this manual. It is essential for preventing trouble and accidents to ensure our satisfaction and safety. Daily inspection and care as per "DAILY INSPECTION CHECKLIST" described in the "INSPECTION AND MAINTENANCE" section of this manual is essential for prolonging the life of the vehicle and for safe driving.

MARUTI SUZUKI INDIA LIMITED believes in conservation and protection of Earth's natural resources.

To that end, we encourage every vehicle owner to recycle, trade-in or properly dispose of, as appropriate, used Engine Oil, coolant and other fluids, batteries and tyres etc.

**MARUTI SUZUKI INDIA LIMITED**

---

**All information in this manual is based on the latest product information available at the time of publication. Due to improvements or other changes, there may be discrepancies between information in this manual and your vehicle. MARUTI SUZUKI INDIA LIMITED reserves the right to make production changes at any time, without notice and without incurring any obligation to make the same or similar changes to vehicles previously built or sold.**

**This vehicle may not comply with standards or regulations of other countries. Before attempting to register this vehicle in any other country, check all applicable regulations and make any necessary modifications.**

---

## IMPORTANT

### **▲ WARNING/ ▲ CAUTION/NOTICE/ NOTE**

Please read this manual and follow its instructions carefully. To emphasize special information, the symbol and the words **WARNING**, **CAUTION**, **NOTICE** and **NOTE** have special meanings. Pay particular attention to messages highlighted by these signal words:

#### **▲ WARNING**

Indicates a potential hazard that could result in death or serious injury.

#### **▲ CAUTION**

Indicates a potential hazard that could result in minor or moderate injury.

#### **NOTICE**

Indicates a potential hazard that could result in vehicle damage.

#### **NOTE:**

*Indicates special information to make maintenance easier or instructions clearer.*

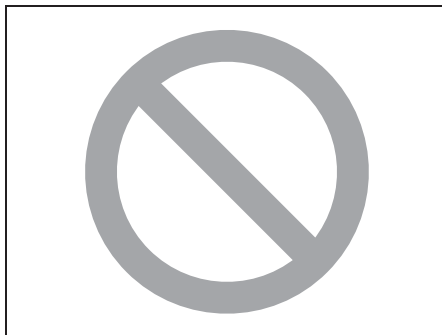

75F135

The circle with a slash in this manual means “Don’t do this” or “Don’t let this happen”.

## MODIFICATION WARNING

### **▲ WARNING**

Do not modify your vehicle. Modification could adversely affect safety, handling, performance, or durability and may violate governmental regulations. In addition, damage or performance problems resulting from modification may not be covered under warranty.

### **NOTICE**

Improper installation of mobile communication equipment such as cellular telephones, CB (Citizen’s Band) radios or any other wireless transmitters may cause electronic interference with your vehicle’s ignition system, resulting in vehicle performance problems. Consult your authorised Maruti Suzuki workshop or qualified service technician for advice.

### **NOTICE**

Severe damage may be caused by the use of either poor quality fuel and/or lubricants not recommended by **MARUTI SUZUKI**.



## VEHICLE DETAILS

MODEL	CHASSIS NO.	ENGINE NO.	KEY NO.	DATE OF DELIVERY	ODOMETER READING (KM)	BATTERY	
						MAKE	SR.NO. BATCH CODE

<b>OWNER'S NAME &amp; ADDRESS</b> _____ _____
E-mail ID _____ TEL.NO. _____

ADDRESS/STAMP OF SELLING DEALER	SELLING DEALER CODE
SHOWROOM	
WORKSHOP	<b>IMPORTANT INFORMATION TO CUSTOMER</b> Dear Customer, For any assistance with regard to our product, please contact General Manager/Works Manager at any of our authorised Maruti Suzuki NEXA dealer / authorised Maruti Suzuki workshop. For additional inquiry you may contact our Regional Office or Service Department. The Addresses and Phone nos. are given in Service Network Booklet provided along with the vehicle.



---

## WARRANTY POLICY

Maruti Suzuki India Limited (hereinafter called “Maruti Suzuki”), warrants that each new Maruti Suzuki vehicle distributed in India by Maruti Suzuki and sold by an authorised Maruti Suzuki NEXA dealer will be free, under normal use and service, from any defects in material and workmanship at the time of manufacture SUBJECT TO THE FOLLOWING TERMS AND CONDITIONS:

### (1) Qualification:

To qualify for this warranty:

The Maruti Suzuki vehicle must be delivered by an authorised Maruti Suzuki NEXA dealer and serviced by authorised Maruti Suzuki workshop.

### (2) Term:

**The term of the warranty shall be twenty-four (24) months or 40,000 kilometers (whichever occurs first) from the date of delivery to the first owner.**

### (3) Maruti Suzuki Warranty Obligation:

If any defect(s) should be found in the vehicle within the term stipulated above, Maruti Suzuki’s only obligation is to repair or replace at its sole discretion any part shown to be defective, with a new part or the equivalent at no cost to the owner for parts or labour, when Maruti Suzuki acknowledges that such a defect is attributable to faulty material or workmanship at the time of manufacture. The owner is responsible for any repair or replacements which are not covered by this warranty.

### (4) Limitation:

This warranty shall not apply to:

- (a) Normal maintenance service required other than the three free services, including without limitation, oil and fluid changes, headlight aiming, fastener retightening, wheel balancing, wheel alignment and tyre rotation, cleaning of injectors, adjustment of clutch and valve clearance.
- (b) The replacement of normal wear parts including without limitation, bulbs, tyres and tubes, spark plugs, belts, hoses, filters, wiper blades, brushes, contact points, fuses, clutch disc, brake shoes, brake pads, cable and all rubber parts (except oil seal and glass run).
- (c) Any vehicle which has been used for competition or racing.
- (d) Any repairs or replacement required as a result of accidents or collision.
- (e) Any defects caused by misuse, negligence, abnormal use or insufficient care.
- (f) Any vehicle which has been modified or altered, including without limitation, the installation of performance accessories.
- (g) Any vehicle on which parts or accessories not approved by Maruti Suzuki have been used.
- (h) Any vehicle which has not been operated in accordance with the operating instructions in this Owner’s Manual and Service Booklet.
- (i) Any vehicle which has not received, during the warranty term, the service inspections prescribed in this Owner’s Manual and Service Booklet.
- (j) Any vehicle which has been assembled, disassembled, adjusted or repaired by other than authorised Maruti Suzuki workshop.
- (k) Any vehicle which has been used for purposes other than what it was designed for.
- (l) Any damage or deterioration caused by industrial pollution and bird droppings.

- 
- (m) Insignificant defects which do not affect the function of the vehicle including without limitation, sound, vibration and fluid seep.
  - (n) Any natural wear and tear including without limitation, aging etc.
  - (o) Installation and usage of domestic LPG gas/LPG Cylinder.
  - (p) V-belts, hoses and gas leaks.
  - (q) Any vehicle retrofitted with LPG/CNG kits.

#### **(5) Extent of Warranty:**

This warranty is the entire written warranty given by Maruti Suzuki for Maruti Suzuki vehicles and no dealer or its or his agent or employee is authorised to extend or enlarge this warranty and no dealer or its or his agent or employee is authorised to make any oral warranty on Maruti Suzuki's behalf.

Maruti Suzuki reserves the right to add any improvements or change the design of any model at any time with no obligation to make the same changes on units previously sold.

#### **(6) Warranty Service:**

To obtain warranty service, the complete vehicle must be presented at the owner's expenses to any authorised Maruti Suzuki workshop.

#### **(7) Owner's Warranty Responsibilities:**

It is responsibility of each owner to:

- Make certain that the PDI card was completed at the time of delivery of the vehicle;
- Have performed, at his own expenses, by an authorised Maruti Suzuki workshop all the service inspections specified in the Maruti Suzuki "Owner's Manual and Service Booklet" and maintain adequate proof that such service inspections have been performed.

- Make certain that the authorised Maruti Suzuki workshop the service inspection has certified the work on the "Maintenance Service Record" page in the "Owner's Manual and Service Booklet" and
- Present the Maruti Suzuki "Owner's Manual and Service Booklet" to the authorised Maruti Suzuki workshop whenever requesting service inspections or warranty service.

If the "Owner's Manual and Service Booklet should be lost or destroyed the owner should consult the authorised Maruti Suzuki workshop from whom the vehicle was purchased for instructions concerning replacement of the "Owner's Manual and Service Booklet.

#### **(8) Disclaimer of Consequential Damage:**

Maruti Suzuki assumes no responsibility for loss of vehicle, loss of time, inconvenience or any other indirect incidental or consequential damage resulting from the vehicle not being available to the owner because of any defect covered by this warranty.

#### **(9) Change of Owner**

Even if ownership of the vehicle changes, the remaining warranty period is effective for the new owner.

---

## EMISSION WARRANTY POLICY

Maruti Suzuki offers the Emission Warranty on all Maruti Suzuki vehicles (apart from the Regular Warranty and will run parallel to the regular product warranty) only in four metropolitan cities (**New Delhi, Kolkata, Mumbai and Chennai**) with effect from July 1st, 2001.

### Terms:

The Emission Warranty will be applicable for **80,000 kms or 3 years** (Whichever comes earlier) from the date of delivery to the first owner. The remaining warranty terms will be valid in case of any change in ownership provided the production of all valid documents.

### Conditions:

1. Under Emission Warranty, Warranty claims will be admitted for a prima-facie examination, in case vehicle fails to meet the Emission Standard as specified in sub rule (2) of rule no. 115 of Central Motor Vehicles Rules (CMVR), 1989.
2. The warranty claims will only be accepted after examination carried out by Maruti Suzuki or authorised Maruti Suzuki workshop which leads to firm conclusions that the
  - a) Original settings have not been tempered in any case.
  - b) Part (as given in Annexure - A) has a manufacturing defect.
  - c) Vehicle is unable to meet the Emission Standards (as given in 1.), inspite of the vehicle having been maintained and used in accordance with the instructions as specified in Owner's Manual and Service Booklet and the used fuel and different oils (Engine oil, Transmission oil, Brake oil etc.) are also as per specification.
3. The method of examination for deciding the warranty of the parts will be at the sole discretion of Maruti Suzuki and authorised Maruti Suzuki workshop and results of the examination will be final and binding. If after examination, the warrantable condition is not established, Maruti Suzuki and authorised Maruti Suzuki workshop has the right to charge all, or part of the cost of such examination.
4. Under Emission Warranty, the parts (as given in Annexure - A) will be changed free of cost, but the consumables will be charged as per actual.
5. If the part covered under Emission Warranty or the associated parts, are not independently replaceable, on account of these being integral parts of a complete assembly, Maruti Suzuki and authorised Maruti Suzuki workshop will have the sole discretion to replace either the entire assembly or by using some of the parts of the system through suitable repairs or modifications.
6. Any consequential repairs or replacement of parts which may be found necessary to establish compliance of Emission Warranty, will not be considered under warranty, unless the same is under product warranty. The consumable will be charged as per actual under such repair or replacement.
7. Maruti Suzuki will not be responsible for the cost of transportation of the vehicle to the nearest authorised Maruti Suzuki workshop or any loss due to non-availability of the vehicle during the period of lodging of a warranty claim and examination and/or repair by authorised Maruti Suzuki workshop.
8. Maruti Suzuki will not be responsible for any penalty that may be charged by statutory authorities on account of failure to comply with the EMISSION STANDARDS.

- 
9. Emission Warranty will not be affected by the change of owner, provided all the documents are available.
  10. All maintenance actions (as specified in the Owner's Manual and Service Booklet) need to be followed and recorded in the manual for emission warranty.
  11. The customer needs to produce the PUC (Pollution Under Control) certificate valid for the period preceding the test during which the failure is discovered. The receipts (for the maintenance of the vehicle as per specification in Owner's Manual and Service Booklet from the date of original purchase of the vehicle) will also be required.

#### **Conditions under which the Emission Warranty is not APPLICABLE**

1. In the absence of valid PUC certificate.
2. Vehicle not serviced from authorised Maruti Suzuki workshop as per the schedule specified in the Owner's Manual and Service Booklet.
3. Vehicle subjected to abnormal use (accident, motor race, rallies or for the purpose of establishing the records etc).
4. Use of non MGP (Maruti Genuine Part).
5. Vehicle that has been tampered with.
6. Tampering with odometer so that the actual kilometer reading can not be determined.
7. Use of adulterated fuel and/or unspecified oils (Engine oil, Transmission oil and Brake oil etc).

#### **Annexure - A**

List of parts covered under Emission Warranty

1. Fuel Injector Assembly, Pressure Regulator, Throttle Body Assembly.
2. Electronic Control Module (ECM).
3. Intake Manifold.
4. EGR valve.
5. Ignition Coil.
6. Canister Assembly.
7. Vapour Liquid Separator.
8. Fuel Tank and Filler Cap.
9. PCV (Positive Crankcase Ventilation) Valve.
10. Oil Filler Cap.
11. Catalytic Converter.
12. Exhaust Manifold.
13. All Fuel Injection System related SENSORS.
14. High Pressure Fuel Pump.
15. Glow Plug.
16. Glow Plug Controller.

---

## TABLE OF CONTENTS

<b>FUEL RECOMMENDATION</b>	<b>1</b>
<b>BEFORE DRIVING</b>	<b>2</b>
<b>OPERATING YOUR VEHICLE</b>	<b>3</b>
<b>DRIVING TIPS</b>	<b>4</b>
<b>OTHER CONTROLS AND EQUIPMENT</b>	<b>5</b>
<b>VEHICLE LOADING AND TOWING</b>	<b>6</b>
<b>INSPECTION AND MAINTENANCE</b>	<b>7</b>
<b>EMERGENCY SERVICE</b>	<b>8</b>
<b>APPEARANCE CARE</b>	<b>9</b>
<b>GENERAL INFORMATION</b>	<b>10</b>
<b>SPECIFICATIONS</b>	<b>11</b>





---

# FUEL RECOMMENDATION

Fuel Recommendation ..... 1-1

## FUEL RECOMMENDATION

---

### Fuel Recommendation

The diesel fuel should be with Cetane Number (CN) higher than 51 and sulfur content less than 350 ppm (parts per million).

MARUTI SUZUKI recommends to use the diesel fuel conformable to EN590. Do not use marine diesel fuel, heating oils and so forth.

#### **NOTICE**

The fuel tank has an air space to allow for fuel expansion in hot weather. If you continue to add fuel after the filler nozzle has automatically shut off or an initial blow-back occurs, the air chamber will become full. Exposure to heat when fully fueled in this manner will result in leakage due to fuel expansion. To prevent such fuel leakage, stop filling after the filler nozzle has automatically shut off, or when using an alternative non-automatic system, initial vent blow-back occurs.

#### **NOTICE**

**Be careful not to spill fuel containing alcohol while refueling. If fuel is spilled on the vehicle body, wipe it up immediately. Fuels containing alcohol can cause paint damage, which is not covered under the New Vehicle Limited Warranty.**

## BEFORE DRIVING

Keys .....	2-1
Door Locks .....	2-3
Keyless Push Start System Remote Controller/ Keyless Entry System Transmitter .....	2-5
Security System (if equipped) .....	2-15
Windows .....	2-18
Mirrors .....	2-20
Front Seats .....	2-23
Rear Seats .....	2-25
Seat Belts and Child Restraint Systems .....	2-28
Supplemental Restraint System (air bags) .....	2-39
Instrument Cluster .....	2-45
Speedometer .....	2-46
Tachometer .....	2-46
Fuel Gauge .....	2-46
Temperature Gauge .....	2-47
Brightness Control .....	2-47
Information Display .....	2-48
Warning and Indicator Lights .....	2-61
Lighting Control Lever .....	2-68
Front Fog Light Switch (if equipped) .....	2-72
Headlight Leveling Switch .....	2-73
Turn Signal Control Lever .....	2-73
Hazard Warning Switch .....	2-74
Windshield Wiper and Washer Lever .....	2-74
Tilt/Telescoping (if equipped) Steering Lock Lever .....	2-78
Horn .....	2-79
Heated Rear Window Switch (if equipped) .....	2-79

### Keys

#### EXAMPLE

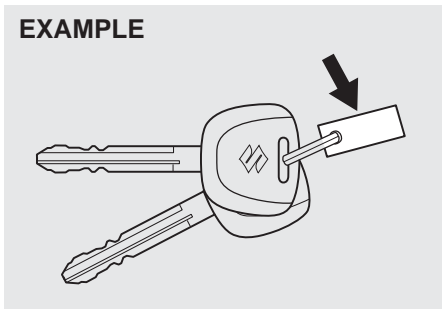

54G489

Your vehicle comes with a pair of identical keys. Keep the spare key in a safe place. One key can open all of the locks on the vehicle.

The key identification number is stamped on a metal tag provided with the keys or on the keys. Keep the tag (if equipped) in a safe place. If you lose your keys, you will need this number to have new keys made. Write the number below for your future reference.

KEY NUMBER:

### Immobilizer System

This system is designed to help prevent vehicle theft by electronically disabling the engine starting system.

The engine can be started only with your vehicle's original immobilizer ignition key or keyless push start system remote controller which has an electronic identification code programmed into it. The key or remote controller communicates the identification code to the vehicle when the ignition switch is turned to the "ON" position or the engine switch is pressed to change the ignition mode to ON. If you need to make spare keys or remote controllers, see your authorised Maruti Suzuki workshop. The vehicle must be programmed with the correct identification code for the spare. A key made by an ordinary locksmith will not start the engine.

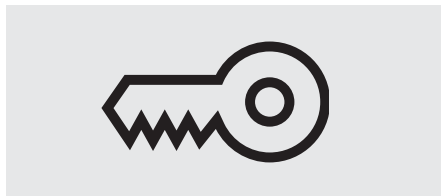

80JM122

If the immobilizer/keyless push start system warning light blinks when the ignition switch is in the "ON" position or the ignition mode is ON, the engine will not start.

**NOTE:**

*If the immobilizer/keyless push start system warning light blinks or comes on, a message may be shown on the information display.*

### For vehicles without keyless push start system

If this light blinks, turn the ignition switch to the "LOCK" position, then turn it back to the "ON" position.

If the light still blinks after the ignition switch is turned back to the "ON" position, there may be something wrong with your key or with the immobilizer system. Ask your authorised Maruti Suzuki workshop to have the system inspected.

### For vehicles with keyless push start system

If this light blinks, change the ignition mode to "LOCK" (OFF), then change back to "ON". Also refer to "If the master warning indicator light blinks and the engine cannot be started" in "Starting the Engine (Vehicle with Keyless Push Start System)" in the "OPERATING YOUR VEHICLE" section.

If the light still blinks after the ignition mode is changed back to "ON", there may be something wrong with your key or with the immobilizer system. Ask your authorised Maruti Suzuki workshop to have the system inspected.

The immobilizer/keyless push start system warning light may also blink if the remote controller is not in the vehicle when you

close the door or attempt to start the engine.

**NOTE:**

- *If you lose your immobilizer ignition key or remote controller, see your authorised Maruti Suzuki workshop as soon as possible to have the lost one deactivated, then have the new key or remote controller made by them.*
- *If you own other vehicles with immobilizer keys, keep those keys away from the ignition switch or the engine switch when using your Vehicle, or the engine may not start because they may interfere with your vehicle's immobilizer system.*
- *If you attach any metal objects to the immobilizer key or remote controller, it may not start the engine.*

**Ignition Key Reminder (if equipped)**

A buzzer sounds intermittently to remind you to remove the ignition key if it is in the ignition switch when the driver's door is opened.

**NOTICE**

**The immobilizer key and remote controller are sensitive electronic instruments. To avoid damaging them:**

- **Do not expose them to impacts, moisture or high temperature such as on the dashboard under direct sunlight.**
- **Keep them away from magnetic objects.**

## BEFORE DRIVING

### Door Locks

#### Side Door Locks

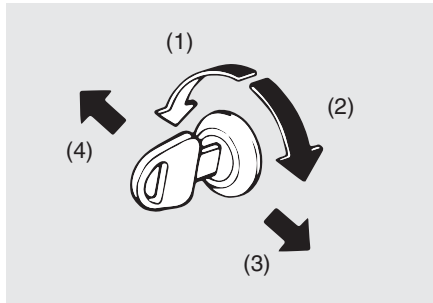

64MS018

- (1) LOCK
- (2) UNLOCK
- (3) Front
- (4) Rear

To lock a front door from outside the vehicle:

- Insert the key and turn the top of the key toward the rear of the vehicle, or
- Turn the lock knob forward, then pull and hold the door handle as you close the door.

To unlock a front door from outside the vehicle, insert the key and turn the top of the key toward the front of the vehicle.

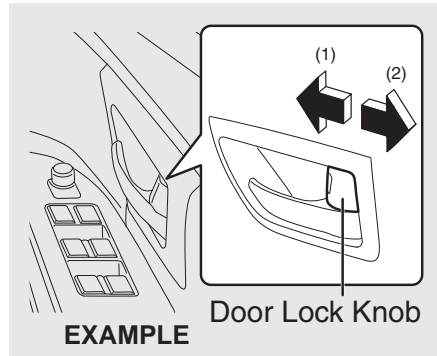

64MS019

- (1) LOCK
- (2) UNLOCK

To lock a door from inside the vehicle, turn the lock knob forward. Turn the lock knob rearward to unlock the door.

To lock a rear door from outside the vehicle, turn the lock knob forward and close the door. You do not need to pull and hold the door handle as you close the door.

#### NOTE:

*Be sure to hold the door handle when you close a locked front door, or the door will not remain locked.*

### Central Door Locking System

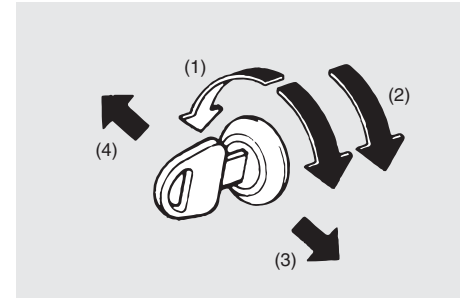

64MS020

- (1) LOCK
- (2) UNLOCK
- (3) Front
- (4) Rear

You can lock and unlock all doors (including the tailgate) simultaneously by using the key in the driver's door lock.

To lock all doors simultaneously, insert the key in the driver's door lock and turn the top of the key toward the rear of the vehicle once.

To unlock all doors simultaneously, insert the key in the driver's door lock and turn the top of the key toward the front of the vehicle twice.

**NOTE:**

You can switch the function that unlocks all doors from twice operations to once operation, and vice versa, via the setting mode of the information display. For details on how to use the information display, refer to "Information Display" in this section.

To unlock the driver's door only, insert the key in that door lock and turn the top of the key toward the front of the vehicle once.

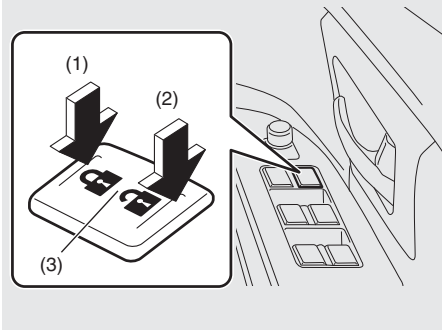
**EXAMPLE**

64MS021

- (1) LOCK  
(2) UNLOCK

You can also lock or unlock all doors by depressing the front or rear of the switch, (3) respectively.

**Note:**

- Individual doors can also be UNLOCKED anytime by using their respective "Door Lock Knob" inside the vehicle.
- If child proof locks are in locked position, rear doors cannot be opened from inside.

**NOTE:**

- You can also lock or unlock all doors by operating the transmitter or remote controller. Refer to "Keyless Push Start System Remote Controller/Keyless Entry System Transmitter" in this section.
- If your vehicle is equipped with the keyless push start system, you can also lock or unlock all doors by pushing the request switch. Refer to "Keyless Push Start System Remote Controller/Keyless Entry System Transmitter" in this section.

**NOTE:**

- All doors are automatically unlocked when you turn the ignition switch to the "LOCK" position and pull out the key, or press the engine switch to change the ignition mode to LOCK (OFF).
- All doors are automatically locked for safety when the vehicle speed reaches 15 km/h.
- You can change the automatic locking or unlocking function mentioned above via the setting mode of the information display. For details on how to use the information display, refer to "Information Display" in this section.

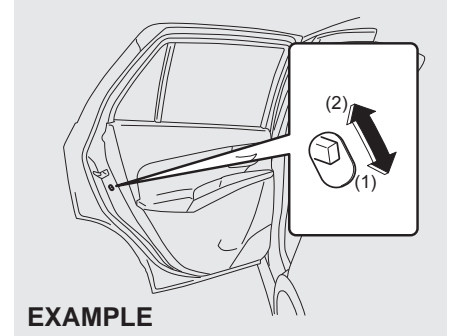
**Child-Proof Locks (rear door)****EXAMPLE**

61MM0A046

- (1) Lock position  
(2) Unlock position

Each of the rear doors is equipped with a child-proof lock which can be used to help prevent unwanted opening of the door from inside the vehicle. When the lock lever is in the lock position (1), the rear door can only be opened from outside. When the lock lever is in the unlock position (2), the rear door can be opened from inside or outside.

**⚠ WARNING**

**Be sure to place the child-proof lock in the lock position whenever children are seated in the rear.**

## BEFORE DRIVING

### **⚠ WARNING**

Always make sure that the tailgate is closed and latched securely. Completely closing the tailgate helps prevent occupants from being thrown from the vehicle in the event of an accident. Completely closing it also helps keep exhaust gases from entering the vehicle.

If you cannot unlatch the tailgate by pushing the unlatch switch (1) due to a discharged battery or malfunction, follow the procedures below to unlatch the tailgate from inside the vehicle.

- 1) Remove the luggage compartment cover (if equipped) and fold the rear seat forward for easier access. Refer to "Folding Rear Seats" section for details on how to fold the rear seat forward.
- 2) Push open the tailgate from inside by pushing up on the emergency lever (2) using a flat blade screwdriver or the jack handle. The tailgate will be latched again by closing the tailgate simply.

### **EXAMPLE**

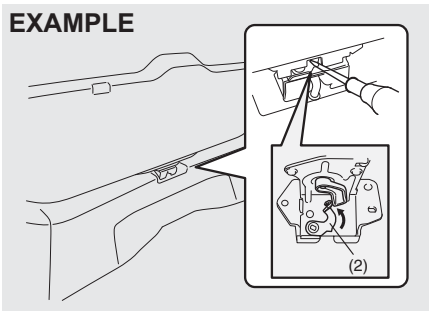

68LM246

If the tailgate cannot be unlatched by pushing the unlatch switch (1), have the vehicle inspected by your authorised Maruti Suzuki workshop.

### **⚠ CAUTION**

- To avoid injury, do not use your finger to push the emergency lever.
- Make sure there is no one near the tailgate when pushing open the tailgate from inside the vehicle.

## Keyless Push Start System Remote Controller/Keyless Entry System Transmitter

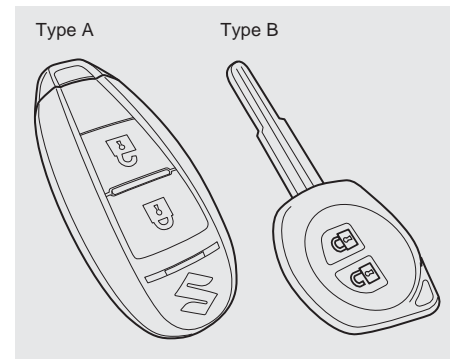

64MS022

Your vehicle is equipped with either a keyless push start system remote controller (Type A) or a keyless entry system transmitter (Type B). The remote controller has a keyless entry system and a keyless push start system. The transmitter has only a keyless entry system. For details, refer to the following explanations.



**⚠ WARNING**

Radio waves from the keyless push start system antenna(s) may interfere with operation of electrical medical equipment such as pacemakers. Failure to take the precautions listed below can increase the risk of severe injury or death due to radio wave interference.

- Anyone who uses electrical medical equipment such as a pacemaker should consult the medical equipment supplier or their medical advisor about whether radio waves from the antenna(s) can interfere with the medical equipment.
- If radio wave interference is a concern, have the function of the antenna(s) disabled by your authorized Maruti Suzuki workshop.

**Keyless Push Start System Remote Controller (Type A)**

The remote controller enables the following operations:

- You can lock or unlock the doors by operating the LOCK/UNLOCK buttons on the remote controller. Refer to the explanation in this section.
- You can lock or unlock the doors by pushing the request switch. For details, refer to the explanation in this section.
- You can start the engine without using an ignition key. For details, refer to "Engine Switch" in the **"OPERATING YOUR VEHICLE"** section.

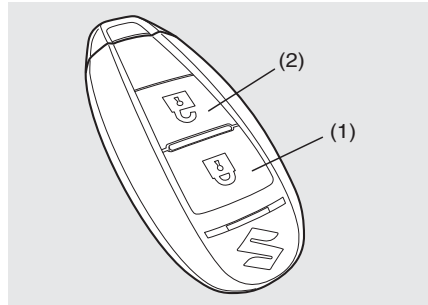

68LM206

- (1) Lock button  
(2) Unlock button

You can lock or unlock all doors (including the tailgate) simultaneously by operating the remote controller near the vehicle.

**Central door locking system**

- To lock all doors, push the "LOCK" button (1) once.
- To unlock only the driver's door, push the "UNLOCK" button (2) once.
- To unlock other doors, push the "UNLOCK" button (2) once again.

**NOTE:**

*You can switch the function that unlocks all doors from twice operations to once operation, and vice versa, via the setting mode of the information display. For details on how to use the information display, refer to "Information Display" in this section.*

The turn signal lights will flash once and the siren will sound once when the doors are locked.

When the doors are unlocked:

- The turn signal lights will flash twice and the siren will sound twice.
- If the interior light switch is in the "DOOR" position, the interior light will turn on for about 15 seconds and then fade out. If you press the engine switch during this time, the light will start to fade out immediately.

Be sure the doors are locked after you operate the "LOCK" button (1).

If no door is opened within about 30 seconds after the "UNLOCK" button (2) is operated, the doors will automatically lock again.

## BEFORE DRIVING

---

### NOTE:

- If you lock the doors using the remote controller when the engine hood is open, the siren will sound 3 times to remind you.
- If the security system was triggered due to an unauthorized entry into the vehicle and then you unlock the doors using the remote controller, the siren will sound 4 times to remind you. If this happens, check whether your vehicle has been broken into while you were away from it.
- Once you push both of the “LOCK” button (1) and “UNLOCK” button (2), then you push one of the buttons within 5 seconds, the siren will not sound. However, if you push one of the buttons twice within 5 seconds, or push one of the buttons 5 seconds later, the siren will sound.
- You can set whether the siren sounds when locking or unlocking the door(s) via the setting mode of the information display. For details on how to use the information display, refer to “**Information Display**” in this section.

### NOTE:

- The maximum operating distance of the remote controller is about 5 m (16 ft.), but this can vary depending on the surroundings, especially near other transmitting devices such as radio towers or CB (Citizen’s Band) radios.
- The door locks cannot be operated with the remote controller if the ignition mode is other than the LOCK (OFF).
- When any door is open, if you push the “LOCK” button on the remote controller,

*the exterior buzzer will sound and doors cannot be locked.*

- *If you lose one of the remote controllers, ask your authorised Maruti Suzuki workshop as soon as possible for a replacement. Be sure to have your dealer program the new remote controller code in your vehicle’s memory so that the old code is erased.*

### Panic alarm function

This function is to get the attention of others.

Push both of the “LOCK” button (1) and “UNLOCK” button (2) for more than 3 seconds. The turn signal lights will blink for about 27.5 seconds. Also, the siren will sound for about 27.5 seconds at the same time.

To cancel the panic alarm, press any button (LOCK OR UNLOCK). You can also change the ignition mode to ON to cancel the panic alarm.

### NOTE:

*The panic alarm function will not activate when the ignition mode is “ACC” or “ON”.*

## Keyless unlocking/locking using the request switches

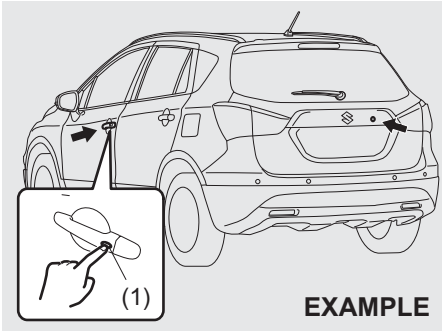

**EXAMPLE**

64MS134

When the remote controller is within the operating range described in this section, you can lock or unlock the doors (including the tailgate) by pushing the request switch (1) on the driver's door handle, front passenger's door handle or tailgate.

To lock all doors when all doors are unlocked:

- To lock all doors, push one of the request switches once.

The turn signal lights will flash once and the siren will sound once when the doors are locked.

To unlock a door or all doors:

- Push one of the request switches once to unlock only one door.
- Push one of the request switches twice to unlock all doors.

### NOTE:

You can switch the function that unlocks all doors from twice operations to once operation, and vice versa, via the setting mode of the information display. For details on how to use the information display, refer to "Information Display" in this section.

When the doors are unlocked:

- The turn signal lights will flash twice and the siren will sound twice.
- If the interior light switch is in the door position, the interior light will turn on for about 15 seconds and then fade out. If you press the engine switch during this time, the light will start to fade out immediately.

Be sure the doors are locked after you operate the request switch to lock the doors.

### NOTE:

- If you lock the doors using the request switch when the engine hood is open, the siren will sound 3 times to remind you.
- If the security system was triggered due to an unauthorized entry into the vehicle and then you unlock the doors using the request switch, the siren will sound 4 times to remind you. If this happens, check whether your vehicle has been broken into while you were away from it.
- You can set whether the siren sounds when locking or unlocking the door(s) via the setting mode of the information display. For details on how to use the information display, refer to "Information Display" in this section.

### NOTE:

- The door locks cannot be operated by the request switch under the following conditions:
  - If any door is open or is not completely closed.
  - If the ignition mode is other than LOCK (OFF).
- If no doors are opened within about 30 seconds after unlocking the doors by pushing the request switch, the doors will be locked again automatically.

### NOTICE

- Do not operate request switch with sharp metal object.
- Do not use high pressure water on request switch.

## BEFORE DRIVING

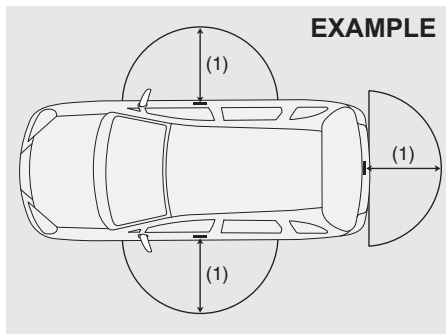

80J056

(1) 80 cm (2 1/2 feet)

When the remote controller is within approximately 80 cm (2 1/2 feet) from a front door handle or the tailgate switch, you can lock or unlock the doors by pushing the request switch.

### NOTE:

- If the remote controller is outside the request switch operating range described above, you will not be able to operate the request switch.
- If the battery of the remote controller runs down or there are strong radio waves or noise, the request switch operating range may be reduced or the remote controller may be inoperative.
- If the remote controller is too close to the door glass, the request switches may not operate.

- If a spare remote controller is in the vehicle, the request switches may not operate normally.
- The remote controller will only operate a request switch if it is within the switch's operating range. For example, if the remote controller is within the operating range of the driver's door request switch but not the front passenger's door request switch or the tailgate request switch, the driver's door switch can be operated but the front passenger's door switch or tailgate switch cannot be operated.
- Avoid operations of switch with sharp objects.

### NOTICE

**The remote controller is a sensitive electronic instrument. To avoid damaging the remote controller:**

- Do not expose it to impacts, moisture or high temperature such as by leaving it on the dashboard under direct sunlight.
- Keep the remote controller away from magnetic objects such as a television.

### NOTE:

The keyless push start system may not function correctly in certain environments or under certain operating conditions such as the following:

- When there are strong signals coming from a television, power station or a cellular phone.
- When the remote controller is in contact with or covered by a metal object.
- When a radio wave type remote keyless entry is used nearby.
- When the remote controller is placed near an electronic device such as personal computer.

Some additional precautions you should take and information you should be aware of are:

- Make sure the key is stowed in the remote controller. If the remote controller becomes unreliable, you will not be able to lock or unlock the doors.
- Be sure that the driver always carries the remote controller.
- If you lose one of the remote controllers, ask your authorised Maruti Suzuki workshop as soon as possible for a replacement. Be sure to have your dealer program the new remote controller code in your vehicle's memory so that the old code is erased.
- You can use up to four remote controllers and the keys for your vehicle. Ask your authorised Maruti Suzuki workshop for details.
- The battery life of the remote controller is about two years, but it can vary depending on usage conditions.

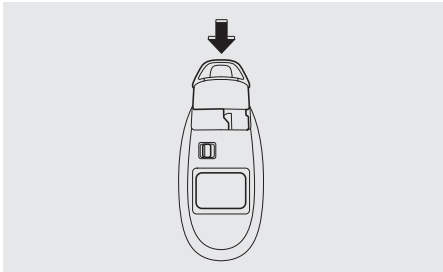

57L21016

To stow the key into the remote controller, push the key in the remote controller until you hear a click.

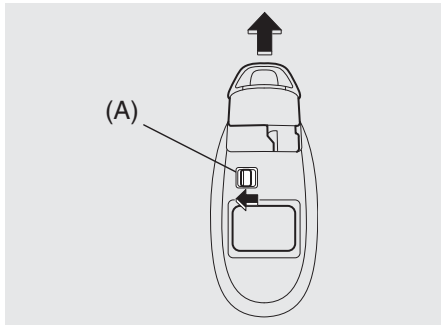

68LM247

To remove the key from the remote controller, push the button (A) in the direction of the arrow and pull the key out from the remote controller.

### Request switch warning buzzer

This exterior buzzer beeps for about 2 seconds in the following conditions to warn you that the request switch is not working:

- The request switch is pressed after all doors are closed with the ignition mode changed to “ACC” or “ON” by pressing the engine switch.
- The request switch is pressed in any of the following conditions after changing the ignition mode to “LOCK” (OFF) by pressing the engine switch.
  - The remote controller is left inside the vehicle.
  - Any door (including the tailgate) is open.

Press the request switch again after doing the following:

With the ignition mode changed to “LOCK” (OFF) by pressing the engine switch, bring out the remote controller if it is inside the vehicle and check that all doors are completely closed.

### Reminder function

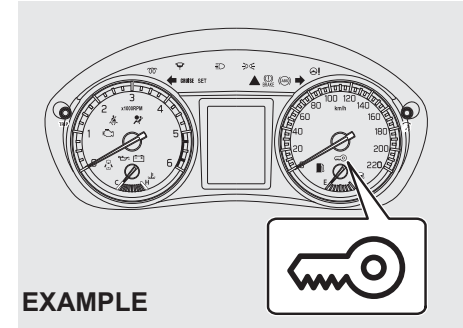

64MS165

If the remote controller is not in the vehicle under the following conditions, the buzzer sounds intermittently for about 2 seconds and the immobilizer/keyless push start system warning light on the instrument cluster blinks:

When one or more doors are opened and all of the doors are later closed with the ignition mode is other than “LOCK”.

The indicator light will turn off within several seconds after the remote controller is returned to an area of the vehicle other than the rear luggage area.

If the remote controller is left in the vehicle and you lock the driver’s door or front passenger’s door as described below, the door will be automatically unlocked.

- If you open the driver’s door and lock the door by turning the lock knob forward or pushing the power door locking switch,

## BEFORE DRIVING

the driver's door will be automatically unlocked.

- If you open the front passenger's door and lock the door by turning the lock knob forward or pushing the power door locking switch, the front passenger's door will be automatically unlocked.

### NOTE:

- *The reminder will not operate when the remote controller is on the instrument panel, in the glove box, in a storage compartment, in the sun visor or on the floor etc.*
- *Be sure that the driver always carries the remote controller.*
- *Do not leave the remote controller in the vehicle when leaving the vehicle.*

### Replacement of the battery

If the remote controller becomes unreliable, replace the battery.

#### NOTICE

**When replacing the battery, do not touch the electronic component in the remote controller with wet or oil-stained hands. Otherwise, the remote controller may be damaged.**

To replace the battery of the remote controller:

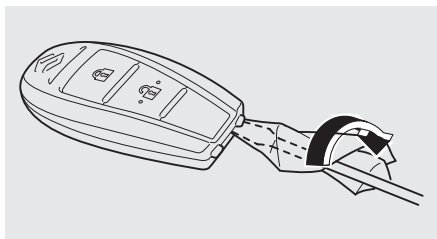

71LMT0201

- 1) Pull the key out from the remote controller.
- 2) Insert a flat blade screwdriver covered with a soft cloth in the slot of the remote controller and pry it open.

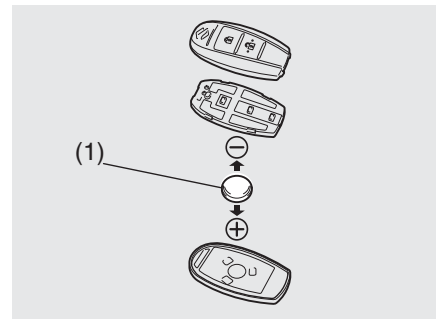

68LM210

- (1) Lithium disc type battery: CR2032 or equivalent
- 3) Replace the battery (1) so its + terminal faces the bottom of the case as shown in the illustration.
- 4) Close the remote controller firmly.
- 5) Make sure the door locks can be operated with the remote controller.
- 6) Dispose of the used battery properly according to applicable rules or regulations. Do not dispose of lithium batteries with ordinary household trash.

#### **⚠ WARNING**

**Swallowing a lithium battery may cause serious internal injury. Do not allow anyone to swallow a lithium battery. Keep lithium batteries away from children and pets. If swallowed, contact a physician immediately.**

**NOTICE**

The remote controller is a sensitive electronic instrument. To avoid damaging it, do not expose it to dust or moisture or tamper with internal parts.

**NOTE:**

Used batteries must be disposed properly according to applicable rules or regulations and must not be disposed with ordinary household trash.

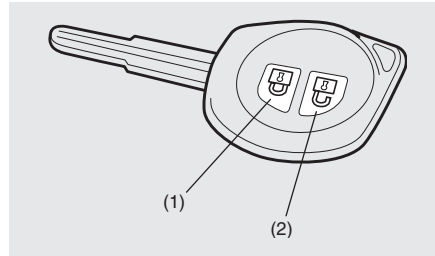
**Keyless Entry System Transmitter (Type B)**

76MS011

- (1) "Lock" button
- (2) "Unlock" button

You can lock or unlock all doors (including the tailgate) simultaneously by operating the transmitter near the vehicle.

**Central door locking system**

- To lock all doors, push the "LOCK" button (1) once.
- To unlock only the driver's door, push the "UNLOCK" button (2) once.
- To unlock other doors, push the "UNLOCK" button (2) once again.

**NOTE:**

You can switch the function that unlocks all doors from twice operations to once operation, and vice versa, via the setting mode of the information display. For details on how to use the information display, refer to "Information Display" in this section.

The turn signal lights will flash once and the siren (if your vehicle is equipped with the security system) will sound once when the doors are locked.

When the doors are unlocked:

- The turn signal lights will flash twice and the siren (if your vehicle is equipped with the security system) will sound twice.
- If the interior light switch is in the "DOOR" position, the interior light will turn on for about 15 seconds and then fade out. If you insert the key into the ignition switch during this time, the light will start to fade out immediately.

Be sure the doors are locked after you operate the lock button (1).

## BEFORE DRIVING

### NOTE:

If no door is opened within about 30 seconds after the unlock button (2) is operated, the doors will automatically lock again.

### NOTE:

(For models with security system)

- If you lock the doors using the transmitter when the engine hood is open, the siren will sound 3 times to remind you.
- If the security system was triggered due to an unauthorized entry into the vehicle and then you unlock the doors using the transmitter, the siren will sound 4 times to remind you. If this happens, check whether your vehicle has been broken into while you were away from it.
- Once you push both of the “LOCK” button (1) and “UNLOCK” button (2), then you push one of the buttons within 5 seconds, the siren will not sound. However, if you push one of the buttons twice within 5 seconds, or push one of the buttons 5 seconds later, the siren will sound.
- You can set whether the siren sounds when locking or unlocking the door(s) via the setting mode of the information display. For details on how to use the information display, refer to “**Information Display**” in this section.

### NOTE:

- The maximum operating distance of the keyless entry system transmitter is about 5 m (16 ft.), but this can vary depending on the surroundings, especially near other transmitting devices such as radio towers or CB (Citizen’s Band) radios.
- The door locks cannot be operated with the transmitter, if the ignition key is inserted in the ignition switch.
- When any door is open, the door locks can be operated only by unlocking with the transmitter. With this unlocking operation, the turn signal lights will flash twice and the siren (if your vehicle is equipped with the security system) will sound twice.
- If you lose one of the transmitters, ask your authorised Maruti Suzuki workshop as soon as possible for a replacement. Be sure to have your dealer program the new transmitter code in your vehicle’s memory so that the old code is erased.

### NOTICE

**The transmitter is a sensitive electronic instrument. To avoid damaging the transmitter:**

- Do not expose it to impacts, moisture or high temperature such as by leaving it on the dashboard under direct sunlight.
- Keep the transmitter away from magnetic objects such as a television.

### Panic alarm function (if equipped)

This function is to get the attention of others.

Push both of the “LOCK” button (1) and “UNLOCK” button (2) for more than 3 seconds. The turn signal lights will blink for about 27.5 seconds. Also, the siren will sound for about 27.5 seconds at the same time.

To cancel the panic alarm, press any button (LOCK or UNLOCK). You can also turn the ignition switch to the “ON” position to cancel the panic alarm.

### NOTE:

The panic alarm function will not activate when the key is in the ignition switch.



**Replacement of the battery**

If the transmitter becomes unreliable, replace the battery.

**NOTICE**

When replacing the battery, do not touch the electronic component in the transmitter with wet or oil-stained hands. Otherwise, the transmitter may be damaged.

To replace the battery of the transmitter:

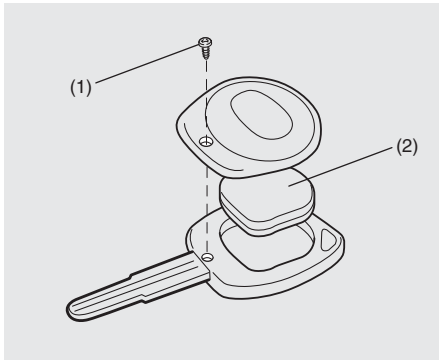

68LM248

- 1) Remove the screw (1), and open the transmitter cover.
- 2) Remove the transmitter (2).

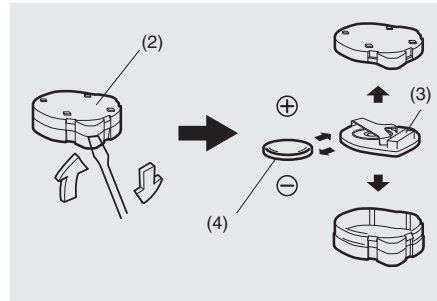

64MS197

- (4) Lithium disc type battery:  
CR1620 or equivalent
- 3) Put the edge of a flat blade screwdriver in the slot of the transmitter (2) and pry it open.
- 4) Hold the cover around the electric component (3), insert a precision screwdriver covered with insulating tape in the space between the cover and the component, and then remove the component.
- 5) Replace the battery (4) so its + terminal faces the "+" mark of the transmitter. Insert the battery all the way into the holder.
- 6) Close the transmitter and install it into the transmitter holder.
- 7) Close the transmitter cover, install and tighten the screw (1).
- 8) Make sure the door locks can be operated with the transmitter.

- 9) Dispose of the used battery properly according to applicable rules or regulations. Do not dispose of lithium batteries with ordinary household trash.

**⚠ WARNING**

Swallowing a lithium battery may cause serious internal injury. Do not allow anyone to swallow a lithium battery. Keep lithium batteries away from children and pets. If swallowed, contact a physician immediately.

**NOTICE**

The transmitter is a sensitive electronic instrument. To avoid damaging it, do not expose it to dust or moisture or tamper with internal parts.

**NOTE:**

Used batteries must be disposed properly according to applicable rules or regulations and must not be disposed with ordinary household trash.

## BEFORE DRIVING

### Security System (if equipped)

The security system is armed in about 5 seconds after you lock all doors (including the tailgate) by using the keyless entry system transmitter, keyless push start system remote controller or request switch.

Once the system is armed, any attempt to open a door by using any other means (\*) than the keyless entry system transmitter, keyless push start system remote controller or request switch, or open the engine hood, will cause the alarm to be triggered.

\* These means include the following:

- The key
- The lock knob on a door
- The central door locking switch

Also, in case that you have set the shock sensor to enabled state and set sensitivity of the pre-warning function and full blast warning function to a level other than 0, the alarm will be triggered if any attempt is made to tamper with the vehicle. The shock sensor can be selected to enabled or disabled state, and sensitivity of each warning can be adjusted as desired. To set the shock sensor, ask your authorised Maruti Suzuki workshop or use the setting mode of the information display.

NOTE:

- The default setting of the shock sensor is in the disabled state. Set to the enabled state and adjust sensitivity of each warning according to your preference. For details on how to use the infor-

mation display, refer to “**Information Display**” in this section.

- Your dealer may have already set the shock sensor of the vehicle to the enabled state before you purchase it. Consult your dealer for further information.

NOTE:

- The security system generates alarms when any of the predetermined conditions is met. However, the system does not have any function of blocking unauthorized entry into the vehicle.
- Always use the keyless entry system transmitter, keyless push start system remote controller or request switch to unlock the doors when the security system has been armed. Using a key instead will trigger the alarm.
- If a person who does not know the security system is going to drive the vehicle, we recommend you explain the system and its operation to the person, or disable the system beforehand. Mistakenly triggering the alarm may cause a nuisance to others.
- Even if the security system is armed, you should still be careful to guard against theft. Do not leave money or things of value in the vehicle.

### How to arm the security system (when enabled)

Lock all doors (including the tailgate) using the keyless entry system transmitter, keyless push start system remote controller or request switch. The security system indicator (1) will start blinking rapidly, and the security system will be armed in about 5 seconds.

While the system is being armed, the indicator continues to blink at intervals of approximately 2 seconds

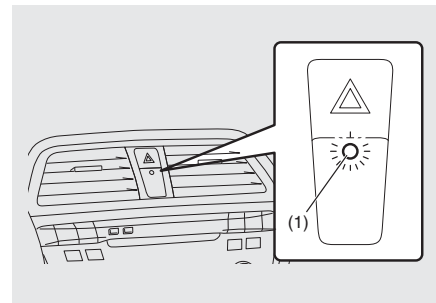

61MM0A134

NOTE:

- To prevent the alarm from being accidentally triggered, avoid arming it while anyone remains inside the vehicle. The alarm will be triggered if any person inside opens the door or engine hood, or swings the vehicle (if the shock sensor is in the enabled state).
- The security system is not armed when all doors are locked using the key from

outside, or using the door lock knobs or the central door locking switch from inside.

- If any door is not operated within approximately 30 seconds after the doors have been unlocked using the keyless entry system transmitter, keyless push start system remote controller or request switch, the doors are automatically locked again. When the doors are locked, the security system will be armed in about 5 seconds if the system is in the enabled state.
- If the security system indicator (1) blinks when the ignition switch is in the "ON" position or the ignition mode is "ON", there may be something wrong with the security system. Ask your authorised Maruti Suzuki workshop to inspect the system.

### How to disarm the security system

Simply unlock the doors using the keyless entry system transmitter, keyless push start system remote controller or request switch. The security system indicator will go out, indicating that the security system is disarmed.

### How to stop the alarm

Should the alarm be triggered accidentally, unlock the doors using the keyless entry system transmitter, keyless push start system remote controller or request switch, or insert the key in the ignition switch and turn it to "ON" position, or press the engine

switch to change the ignition mode to "ON". The alarm will then stop.

#### NOTE:

- Even after the alarm has stopped, if you lock the doors using the keyless entry system transmitter, keyless push start system remote controller or request switch, the security system will be rearmed with a delay of about 5 seconds.
- If you disconnect the battery while the security system is in the armed condition or the alarm is actually in operation, the alarm will be re-triggered when the battery is then reconnected.
- Even after the alarm has stopped at the end of the predetermined operation time, it will be triggered again if any of the doors or engine hood is opened, or the vehicle feels a shock (if the shock sensor is in the enabled state), without disarming the security system.

### Checking whether the alarm has been triggered during parking

If the alarm was triggered and you then turn the ignition switch to "ON" position, or press the engine switch to change the ignition mode to "ON", the security system indicator will blink rapidly for about 8 seconds and a buzzer will beep 4 times during this period. If this happens, check whether the vehicle has been broken into while you were away from it.

### Enabling and disabling the security system

The security system can be either enabled or disabled.

#### When enabled

- If any of the doors are opened without unlocking by the keyless entry system transmitter, keyless push start system remote controller or request switch, all turn signal lights start to blink and the interior buzzer beeps intermittently. After 5 seconds, the siren will sound for about 27.5 seconds. The security system indicator continues to blink during this time.
- If the engine hood is opened, all turn signal lights blink, and the siren sounds for about 27.5 seconds. The security system indicator continues to blink during this time.

#### (If the shock sensor is in the enabled state)

- If the vehicle feels a shock, the siren sounds for about 2 seconds (pre-warning). If the vehicle continues to feel a shock, all turn signal lights start to blink and the interior buzzer beeps intermittently. After 5 seconds, the siren will sound for about 27.5 seconds (full blast warning). The security system indicator continues to blink during this time.

#### NOTE:

If you set the full blast warning sensitivity higher than the pre-warning sensitivity in the setting mode of the information display, or the vehicle feels such shock as to be

## BEFORE DRIVING

able to trigger the full blast warning, the full blast warning will be triggered preferentially. In this case, the pre-warning will not be triggered.

### When disabled

When the system is disabled, it stays disarmed even if you perform any system arming operation.

### How to switch the state of the security system

When the security system has been already disarmed, you can switch the system from the enabled state to the disabled state, and vice versa, using the following method.

- 1) Sit in the driver's seat and make sure that all doors are closed, and then turn the ignition switch to "ON" position or press the engine switch to change the ignition mode to ON.
  - If any door is open, the open door warning light comes on.

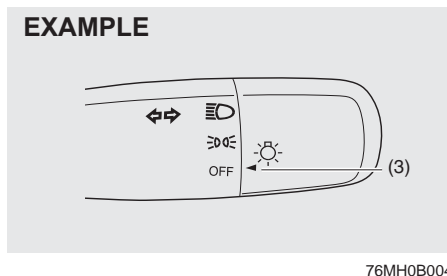
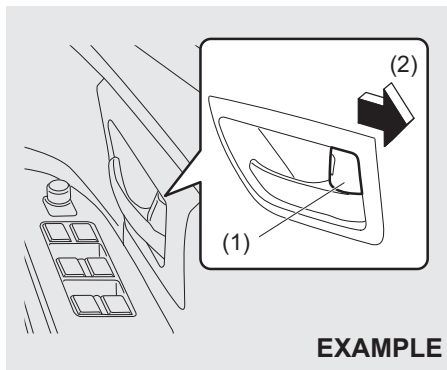

- 2) Turn the lock knob (1) on the driver's door rearward (2). Turn the knob on the lightning control lever to the OFF position (3).

**NOTE:**  
The following steps 3) and 4) must be completed within 15 seconds.

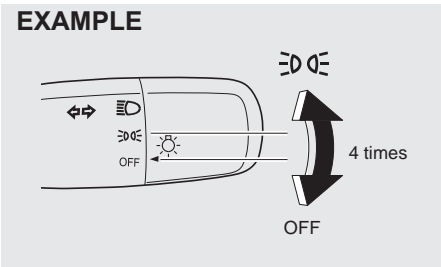

- 3) Turn the knob on the lighting control lever to the  $\text{OFF}$  position and then turn back to the  $\text{OFF}$  position. Repeat this operation 4 times.

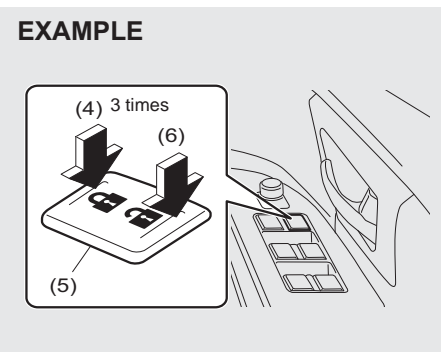

- 4) Push the lock end (4) (forward end) of the central door locking switch (5), and

then push the unlock end (6) (backward end). Repeat this operation 3 times.

Every time you perform the series of the above steps, the state of the security system changes from the currently selected one to the other. You can check whether the system is enabled or disabled by the number of interior buzzer beeps at the end of the procedure as follows.

System state	Number of beeps
Disabled (Mode A)	Once
↕	
Enabled (Mode D)	4 times

- If you cannot complete the operations in step 3) and 4) within 15 seconds correctly, the state of the security system will not change and the interior buzzer does not beep. Perform the procedure again from the beginning.

**NOTE:**

You can also switch the security system from the enabled state to the disabled state, and vice versa, via the setting mode of the information display. For details on how to use the information display, refer to **“Information Display”** in this section.

## Windows

### Electric Window Controls

The electric windows can only be operated when the ignition switch is in the “ON” position or the ignition mode is ON.

#### Driver’s side

##### EXAMPLE

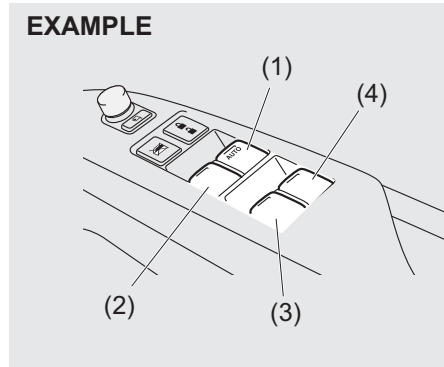

64MS025

The driver's door has a switch (1) to operate the driver's window, and a switch (2) to operate the front passenger's window or there are switches (3), (4), to operate the rear left and right passenger windows, respectively.

#### Passenger’s door

##### EXAMPLE

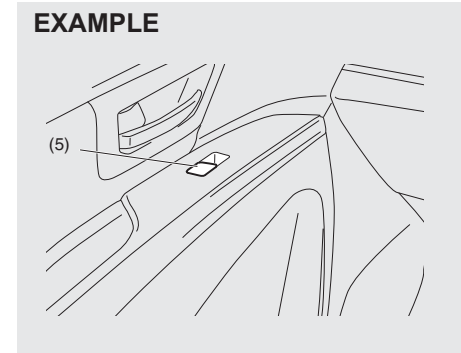

64MS026

The passenger's door has a switch (5) to operate the passenger's window.

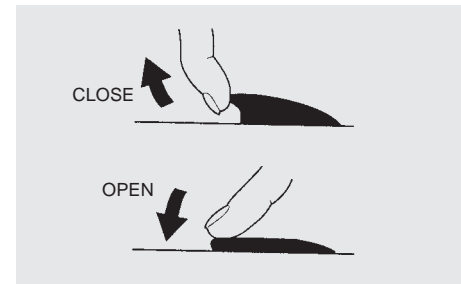

81A009

To open a window, push the top part of the switch and to close the window lift up the top part of the switch.

## BEFORE DRIVING

The driver's window has auto-down and auto-up features for added convenience (at toll booths or drive-through restaurants, for example). This means the driver can open or close the window without holding the window switch in the down or up position. Press down or lift up the driver's window switch completely and release it. To stop the window before it reaches the full-down or full-up position, pull up or push down the switch briefly.

### Lock switch

#### EXAMPLE

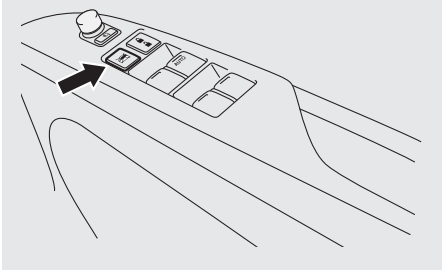

64MS027

The driver's door also has a lock switch for the passenger's window(s). When you push in the lock switch, the passenger's window(s) cannot be raised or lowered by operating any of the switches (2), (3), (4) or (5). To restore normal operation, release the lock switch by pushing again.

### ⚠ WARNING

- **You should always lock the passenger's window operation when there are children in the vehicle. Children can be seriously injured if they get part of their body caught by the window during operation.**
- **To avoid injuring an occupant by window entrapment, be sure no part of the occupant's body such as hands or head is in the path of the electric windows when closing them.**
- **Always remove the ignition key or take the keyless push start system remote controller with you when leaving the vehicle even if only for a short time. Also do not leave children alone in a parked vehicle. Unattended children may operate the electric window switches and get trapped by the window.**

#### NOTE:

*If you drive with one of the rear windows open, you may hear a loud sound caused by air vibration. To reduce the sound, open the driver's or front passenger's window, or narrow the rear window opening.*

## Pinching Prevention Function

The driver's window is equipped with the pinching prevention function. The function detects a foreign object caught in the window while being closed by the "auto-up" feature, which you can close the window without holding the window switch in the "UP" position, and stops the window closing to prevent damage.

### ⚠ WARNING

**To avoid injuring an occupant by window entrapment, be sure no part of the occupant's body such as hands or head is in the path of the electric window when closing it. The function may not detect the object depending on size, hardness, and position of the object caught by the closing window.**

### ⚠ CAUTION

- **The pinching prevention function does not act while you are holding the window switch in the "UP" position.**
- **The pinching prevention function may not detect an object caught in the window just before the window is fully closed.**

**NOTE:**

Even if you cannot close the window by the auto-up feature because there may be something wrong with the pinching prevention function, you can close the window by holding the window switch in the up position.

If you drive in extreme off-road condition, the pinching prevention function may operate accidentally because the window react to vehicle jolting.

**The Pinching Prevention Function Initialization**

When you disconnect and re-connect the battery or replace the fuse, the function will be deactivated. In this condition, the auto-down feature will be deactivated, while the auto-up feature may remain being activated. The pinching prevention function needs to be initialized.

To initialize the pinching prevention function, use the following procedure:

- 1) Turn the ignition switch to the "ON" position or press the engine switch to change the ignition mode to "ON".
- 2) Open the driver's window fully by holding the window switch in the "DOWN" position.
- 3) Close the driver's window by holding the switch in the "UP" position, and keep holding the switch for 2 seconds after the window fully closed.
- 4) Check the driver's window if the auto-down/up feature work.

**⚠ WARNING**

**Whenever you disconnect and reconnect the battery or replace the fuse, the pinching prevention function needs to be initialized. The pinching prevention function will not be activated until the initialization complete.**

If the auto-down/up feature would not work after initialization, there might be something wrong with the pinching prevention function. Have your vehicle inspected by an authorised Maruti Suzuki workshop.

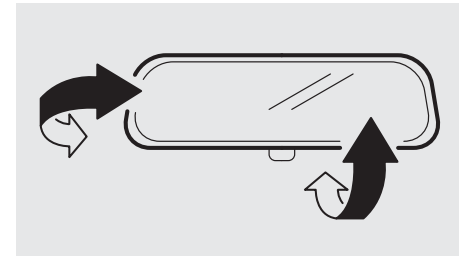
**Mirrors****Inside Rearview Mirror**

68LMT0205

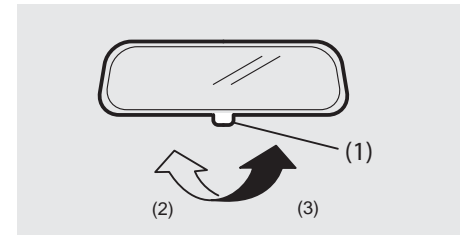

68LMT0206

- (2) Day driving  
(3) Night driving

You can adjust the inside rearview mirror by hand so as to see the rear of your vehicle in the mirror. To adjust the mirror, set the selector tab (1) to the day position, then move the mirror up, down or sideways by hand to obtain the best view.

## BEFORE DRIVING

When driving at night, you can move the selector tab to the night position to reduce glare from the headlights of vehicles behind you.

### WARNING

- Always adjust the mirror with the selector set to the day position.
- Only use the night position if it is necessary to reduce glare from the headlights of vehicles behind you. Be aware that in this position you may not be able to see some objects that could be seen in the day position.

### Auto Dimming Rearview Mirror (if equipped)

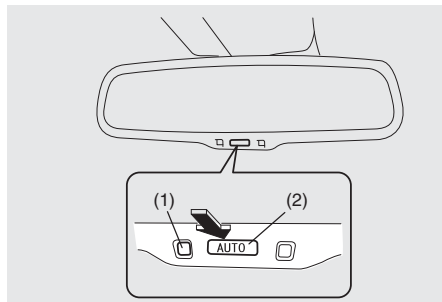

57L30019

You can adjust the auto dimming rearview mirror by hand so you can see to the rear of your vehicle in the mirror. This rearview mirror has a function of automatically reducing glare from the lights of vehicles behind you. The function works when the ignition mode has been changed to "ON" by pressing the engine switch.

- The mirror is always set to the automatic dimming mode when the engine switch is in the "ON" mode.
- When the "AUTO" switch (2) is pushed, the green indicator (1) is lit, indicating that the mirror is set to the automatic dimming mode. To cancel the automatic dimming mode, push the "AUTO" switch (2); the indicator (1) then goes out.
- The auto dimming rearview mirror is automatically deactivated while the gear-shift lever is in the "R" position.

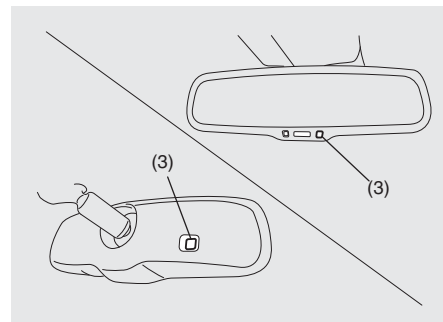

57L30020

### WARNING

Do not touch or cover the sensor (3) since this may impair normal operation of the system. Blocking glare from the sensor with an object such as a shade, sticker, accessory or baggage may also impair proper operation of the system.

### NOTICE

Do not hook anything heavy on the mirror, or the mirror may break under the weight.



### Outside Rearview Mirrors

Adjust the outside rearview mirrors so you can just see the side of your vehicle in the mirrors.

#### **⚠ WARNING**

**Be careful when judging the size or distance of a vehicle or other object seen in the side convex mirror. Be aware that objects look smaller and appear farther away than when seen in a flat mirror.**

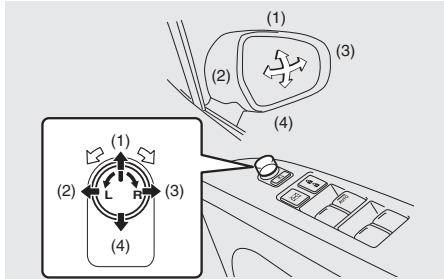

64MS028

The switch to control the electric mirrors is located on the driver's door panel. You can adjust the mirrors when the ignition switch is in the "ACC" or "ON" position, or the ignition mode is "ACC" or "ON". To adjust the mirrors:

- 1) Move the selector switch to the left or right to select the mirror you wish to adjust.

- 2) Press the outer part of the switch that corresponds to the direction in which you wish to move the mirror.
- 3) Return the selector switch to the center position to help prevent unintended adjustment.

### Outside Rearview Mirrors Folding Switch (if equipped)

#### EXAMPLE

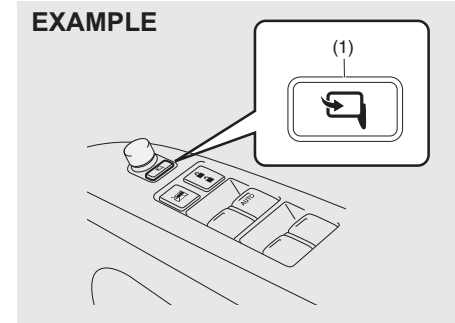

64MS029

You can fold the mirrors when you park the vehicle in a narrow space. When the ignition switch is in the "ACC" or "ON" position, or the ignition mode is "ACC" or "ON", push the folding switch (1) to fold and unfold the mirrors. Make sure the mirrors are completely unfolded before you start driving.

#### **⚠ CAUTION**

**Moving mirrors can pinch and injure a hand. Do not allow any one's hand to get near the mirrors when folding and unfolding the mirrors.**

## BEFORE DRIVING

### Front Seats

#### Seat Adjustment

#### **⚠ WARNING**

Never attempt to adjust the driver's seat or seatback while driving. The seat or seatback could move unexpectedly, causing loss of control. Make sure that the driver's seat and seatback are properly adjusted before you start driving.

#### **⚠ WARNING**

To avoid excessive seat belt slack, which reduces the effectiveness of the seat belts as a safety device, make sure that the seats are adjusted before the seat belts are fastened.

#### **⚠ WARNING**

All seatbacks should always be in an upright position when driving, or seat belt effectiveness may be reduced. Seat belts are designed to offer maximum protection when seatbacks are in the upright position.

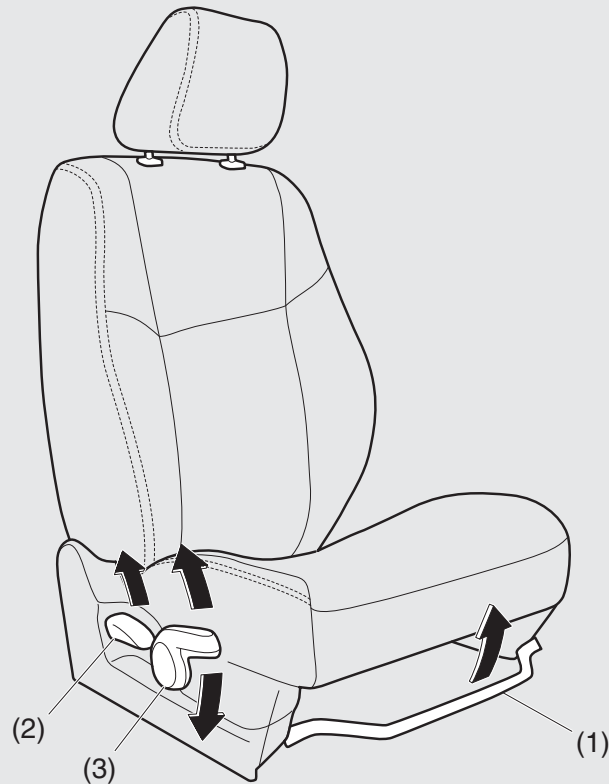

64MS154

**Seat position adjustment lever (1)**

Pull the lever up and slide the seat.

**Seatback angle adjustment lever (2)**

Pull the lever up and move the seatback.

**Seat height adjustment lever (3) (if equipped)**

Pull the lever up to raise the seat. Push the lever down to lower the seat.

After adjustment, try to move the seat and seatback forward and rearward to ensure that it is securely latched.

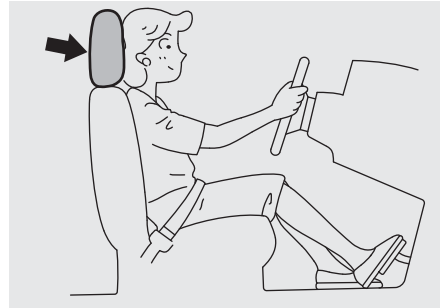
**Head Restraints**

80J001

Head restraints are designed to help reduce the risk of neck injuries in the case of an accident. Adjust the head restraint to the position which places the center of the head restraint closest to the top of your ears. If this is not possible for very tall passengers, adjust the head restraint as high as possible.

**⚠ WARNING**

- Never drive the vehicle with the head restraints removed.
- Do not attempt to adjust the head restraint while driving.

**NOTE:**

*It may be necessary to recline the seatback to provide enough overhead clearance to remove the head restraint.*

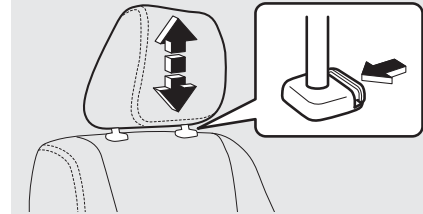
**Front****EXAMPLE**

64MS163

To raise the front head restraint, pull upward on the restraint until it clicks. To lower the restraint, push down on the restraint while holding in the lock lever. If a head restraint must be removed (for cleaning, replacement, etc.), push in the lock lever and pull the head restraint all the way out.

## BEFORE DRIVING

### Rear Seats

#### Seat Adjustment

#### WARNING

To avoid excessive seat belt slack, which reduces the effectiveness of the seat belts as a safety device, make sure that the seats are adjusted before the seat belts are fastened.

#### WARNING

All seatbacks should always be in an upright position when driving, or seat belt effectiveness may be reduced. Seat belts are designed to offer maximum protection when seatbacks are in the upright position.

#### EXAMPLE

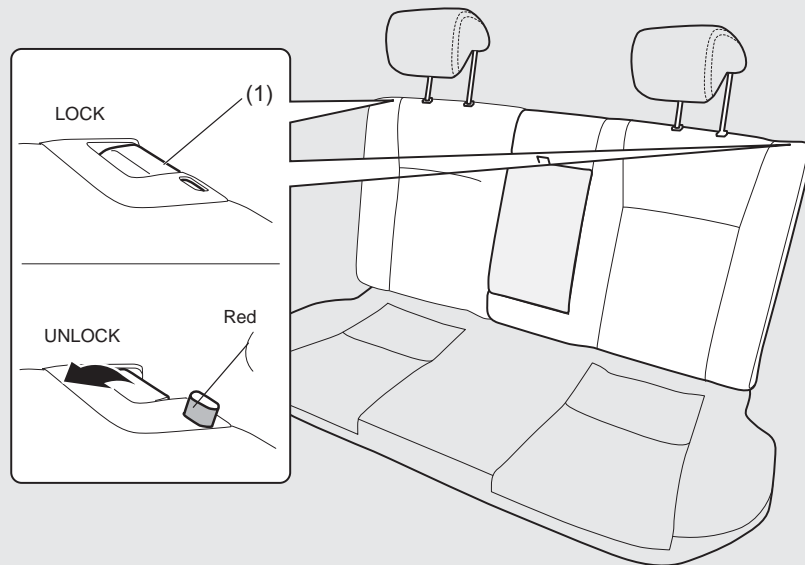

64MS155

**Seatback angle adjustment lever (1)  
(if equipped)**

Pull the lever up and move the seatback. After adjustment, try to move the seatback forward and rearward to ensure that it is securely latched.

**⚠ CAUTION**

After securing the rear seatback, make sure that it is locked securely. If it is not, red will appear beside the lever.

**Head Restraints**

Head restraints are designed to help reduce the risk of neck injuries in the case of an accident.

**⚠ WARNING**

- Never drive the vehicle with the head restraints removed.
- Do not attempt to adjust the head restraint while driving.

*NOTE:*

*It may be necessary to fold forward the seatback to provide enough overhead clearance to remove the head restraint.*

Adjust the head restraint to the position which places the center of the head restraint closest to the top of your ears. If this is not possible for very tall passengers, adjust the head restraint as high as possible.

**Rear**

**EXAMPLE**

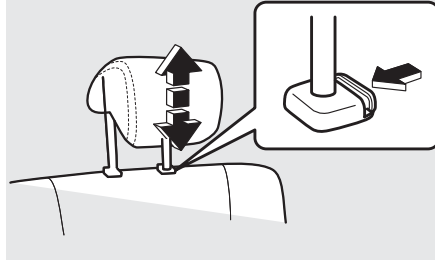

64MS156

To raise the rear head restraint, pull upward on the restraint until it clicks. To lower the restraint, push down on the restraint while holding in the lock lever. If a head restraint must be removed (for cleaning, replacement, etc.), push in the lock lever and pull the head restraint all the way out.

When installing a child restraint system, raise the head restraint to the most upper position.

**Folding Rear Seat (s)**

The rear seat (s) of your vehicle can be folded forward to provide additional cargo space.

To fold the rear seat (s) forward:

- 1) Lower the head restraint fully.

**EXAMPLE**

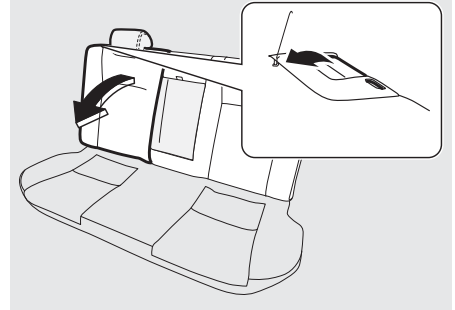

64MS157

- 2) Pull the release lever on the top of each split seat, and fold the seatback (s) forward.

**NOTICE**

After folding the rear seatback forward, do not allow any foreign material to enter the lock opening. This may cause damage to the inside of the lock and prevent the seatback from being locked securely.

## BEFORE DRIVING

### **⚠ WARNING**

If you need to carry cargo in the passenger compartment with the rear seat back folded forward, be sure to secure the cargo or it may be thrown about, causing injury. Never pile cargo higher than the seatbacks.

To return the seat to the normal position, follow the procedure below.

### **⚠ CAUTION**

When returning the rear seatback to the normal position, be careful that your finger is not caught between the lock and the striker.

### **NOTICE**

When returning the rear seatback to the normal position, make sure that there is nothing around the striker. Any foreign materials prevent the seatback from being locked securely.

### **EXAMPLE**

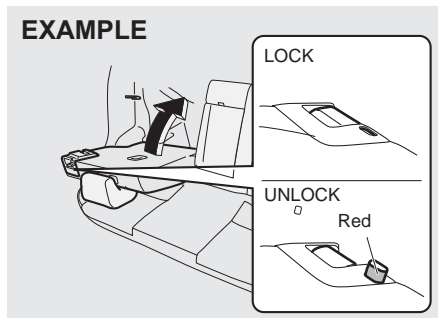

64MS145

Raise the seatback until it locks into place.

### **EXAMPLE**

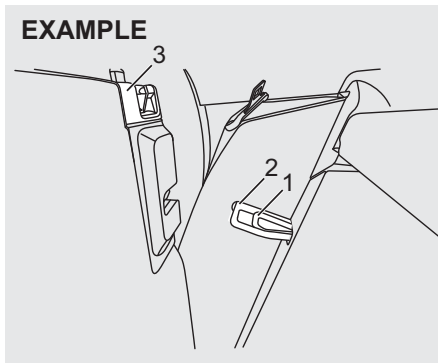

64MS201

The rear seatback (3) will lock in two positions (1) and (2). You can lock the rear seatback in position (2) to increase the luggage compartment area.

After returning the seat, try to move the seatback forward and rearward to ensure that it is securely latched.

### **⚠ CAUTION**

Do not put your hand into the rear seatback lock opening, or your finger may get caught and be injured.

### **⚠ CAUTION**

After securing the rear seatback, make sure that it is locked securely. If it is not, red will appear beside the release lever.

**NOTICE**

- When returning the rear seatback to the normal position, do not allow any foreign material to enter the lock opening. This may prevent the seatback from being locked securely.
- When returning the rear seatback to the normal position, be sure to handle it carefully by hand to avoid any damage to the lock itself. Do not push it by using some material or by applying excessive force.
- As the lock is designed exclusively for securing the rear seatback, do not use it for any other purpose. Incorrect use of it may cause damage to the inside of the lock and prevent the seatback from being locked securely.

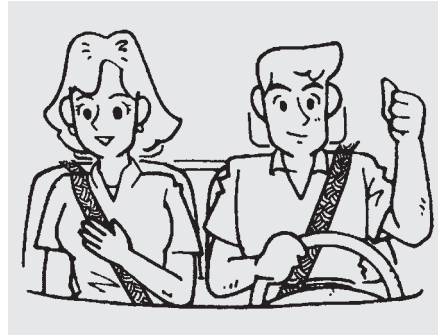
**Seat Belts and Child Restraint Systems**

65D231S

**⚠ WARNING****Wear Your Seat Belts at All Times.****⚠ WARNING**

An air bag supplements, or adds to, the frontal crash protection offered by seat belts. The driver and all passengers must be properly restrained by wearing seat belts at all times, whether or not an air bag is mounted at their seating position, to minimize the risk of severe injury or death in the event of a crash.

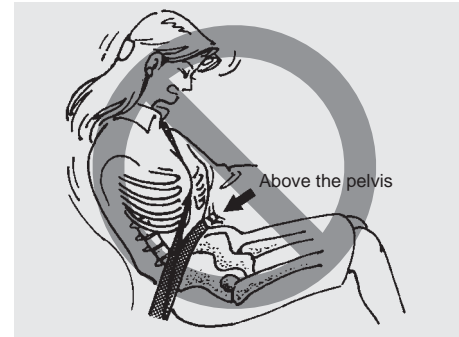

65D606

**⚠ WARNING**

- Never allow persons to ride in the cargo area of a vehicle. In the event of an accident, there is a much greater risk of injury for persons who are not riding in a seat with their seat belt securely fastened.
- Seat belts should always be adjusted as follows:
  - the lap portion of the belt should be worn low across the pelvis, not across the waist.
  - the shoulder straps should be worn on the outside shoulder only, and never under the arm.
  - the shoulder straps should be away from your face and neck, but not falling off your shoulder.

(Continued)

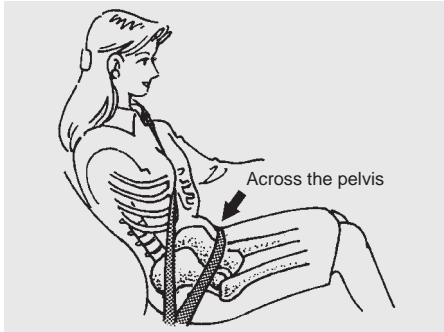

65D201

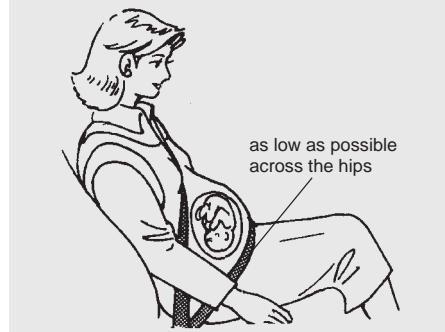

65D199

**⚠ WARNING**

(Continued)

- Seat belts should never be worn with the straps twisted and should be adjusted as tightly as is comfortable to provide the protection for which they have been designed. A slack belt will provide less protection than one which is snug.
- Make sure that each seat belt buckle is inserted into the proper buckle catch. It is possible to cross the buckles in the rear seat.

(Continued)

**⚠ WARNING**

(Continued)

- Pregnant women should use seat belts, although specific recommendations about driving should be made by the woman's medical advisor. Remember that the lap portion of the belt should be worn as low as possible across the hips, as shown in the diagram.
- Do not wear your seat belt over hard or breakable objects in your pockets or on your clothing. If an accident occurs, objects such as glasses, pens, etc. under the seat belt can cause injury.

(Continued)

**⚠ WARNING**

(Continued)

- Never use the same seat belt on more than one occupant and never attach a seat belt over an infant or child being held on an occupant's lap. Such seat belt use could cause serious injury in the event of an accident.
- Periodically inspect seat belt assemblies for excessive wear and damage. Seat belts should be replaced if webbing becomes frayed, contaminated, or damaged in any way. It is essential to replace the entire seat belt assembly after it has been worn in a severe impact, even if damage to the assembly is not obvious.
- Children age 12 and under should ride properly restrained in the rear seat.
- Infants and small children should never be transported unless they are properly restrained. Restraint systems for infants and small children can be purchased locally and should be used. Make sure that the system you purchase meets applicable safety standards. Read and follow all the directions provided by the manufacturer.

(Continued)



**⚠ WARNING**

(Continued)

- For children, if the shoulder belt irritates the neck or face, move the child closer to the center of the vehicle.
- Avoid contamination of seat belt webbing by polishes, oils, chemicals, and particularly battery acid. Cleaning may safely be carried out using mild soap and water.
- Do not insert any items such as coins, clips, etc. into the seat belt buckles, and be careful not to spill liquids into these parts. If foreign materials get into a seat belt buckle, the seat belt may not work properly.
- All seatbacks should always be in an upright position when driving, or seat belt effectiveness may be reduced. Seat belts are designed to offer maximum protection when seatbacks are in the upright position.

**Lap-Shoulder Belt****Emergency Locking Retractor (ELR)**

The seat belt has an emergency locking retractor (ELR), which is designed to lock the seat belt only during a sudden stop or impact. It also may lock if you pull the belt across your body very quickly. If this happens, let the belt go back to unlock it, then pull the belt across your body more slowly.

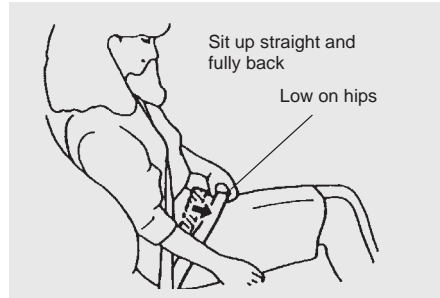
**Safety reminder**

60A038

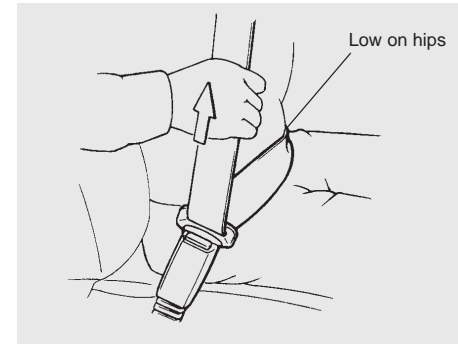

60A040

To reduce the risk of sliding under the belt during a collision, position the lap portion of the belt across your lap as low on your hips as possible and adjust it to a snug fit by pulling the shoulder portion of the belt upward through the latch plate. The length of the diagonal shoulder strap adjusts itself to allow freedom of movement.

## BEFORE DRIVING

### All Seat Belts Except Rear Center

All seat belts except rear center are the lap-shoulder belt.

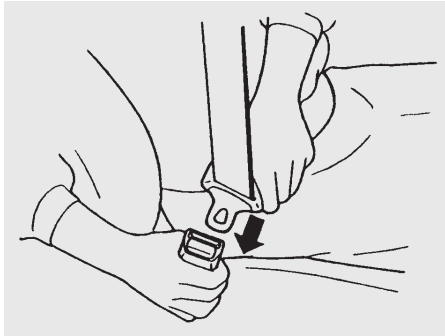

60A036

To fasten the seat belt, sit up straight and well back in the seat, pull the latch plate attached to the seat belt across your body and press it straight into the buckle until you hear a click.

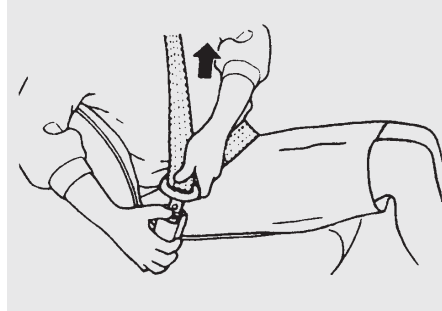

60A039

To unfasten the seat belt, push the button on the buckle and retract the belt slowly while attaching a hand to the belt or/and the latch plate.

### Rear Center Seat Belt

Rear center seat belt is the lap belt. To fasten the belt, pull the latch plate attached to the seat belt across your hips and press it straight into the buckle until you hear a click. To reduce the risk of sliding under the belt during a collision, position the belt across your lap as low on your hips as possible and adjust it to a snug fit.

#### TO TIGHTEN

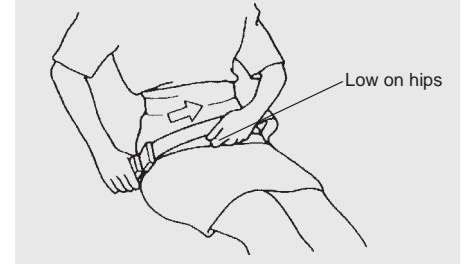

80JS028

To tighten the belt, pull the free end of the belt across alongside the lap strap.

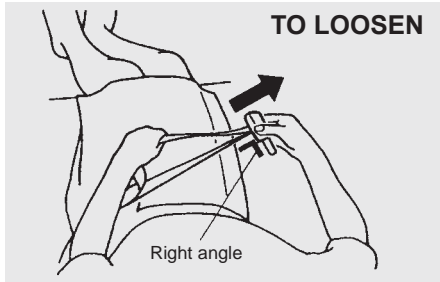

80JS029

To lengthen, release the latch plate from the buckle, pull the latch plate (adjuster) in the direction of the arrow, at right angles to the belt. The latch plate should then be refitted into the buckle and the belt tightened as previously described.  
To unfasten the belt, press the release button on the buckle catch.

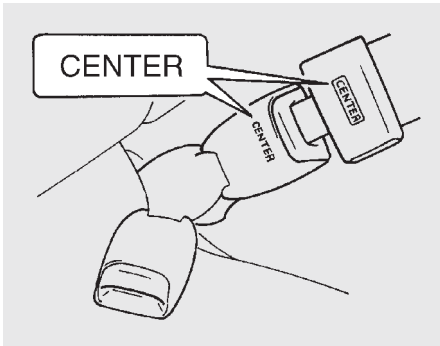

80JS031

**NOTE:**

To identify the center seat belt buckle and latch plate in the rear seat, "CENTER" is marked on the buckle and latch plate of the center lap belt. The buckles are designed so a latch plate cannot be inserted into the wrong buckle.

**Driver's Seat Belt Reminder**

**EXAMPLE**

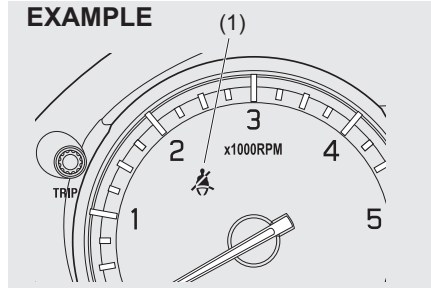

64MS045

(1) Driver's seat belt reminder light

When the driver doesn't buckle his or her seat belt, with the ignition switch in the "ON" position or the ignition mode "ON" the driver's seat belt reminder light in the instrument cluster will blink and a buzzer will sound as a reminder to the driver to buckle his or her seat belt. For more details, refer to the explanation below:

If the driver's seat belt remains unbuckled when the ignition switch is in the "ON" position or the ignition mode is "ON", the reminder works as follows:

1. The driver's seat belt reminder light will come on.
2. After the vehicle's speed has reached about 15 km/h, the driver's seat belt reminder light will blink and a buzzer will sound for about 95 seconds.
3. After step 2) has finished, the reminder light will remain on until the driver's seat belt is buckled.

If the driver has buckled his or her seat belt and later unbuckles the seat belt, the seat belt reminder system will be activated from step 1) or step 2) according to vehicle's speed. When the vehicle's speed is below about 15 km/h, the reminder will start from step 1). When the vehicle's speed is above about 15 km/h, the reminder will start from step 2).

The reminder will be automatically canceled when the driver's seat belt is buckled or the ignition switch is turned off / ignition mode is switched to OFF position.

**▲ WARNING**

**It is absolutely essential that the driver and passengers wear their seat belts at all times. Persons who are not wearing seat belts have a much greater risk of injury if an accident occurs. Make a regular habit of buckling your seat belt before putting the key in the ignition or pressing the engine switch.**

## BEFORE DRIVING

### Shoulder Anchor Height Adjuster

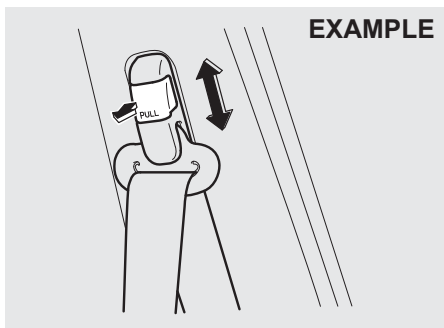

64J198

Adjust the shoulder anchor height so that the shoulder belt rides on the center of the outboard shoulder. To move upward, slide the anchor up. To move downward, slide the anchor down while pulling the lock knob out. After adjustment, make sure that the anchor is securely locked.

#### **⚠ WARNING**

Be sure that the shoulder belt is positioned on the center of the outside shoulder. The belt should be away from your face and neck, but not falling off your shoulder. Misadjustment of the belt could reduce the effectiveness of the safety belt in a crash.

### Seat Belt Inspection

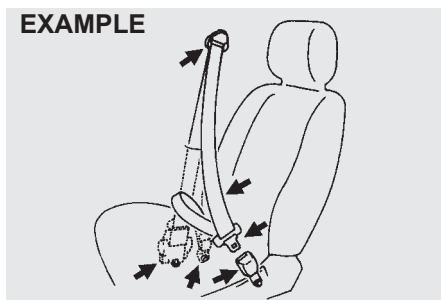

65D209S

Periodically inspect the seat belts to make sure they work properly and are not damaged. Check the webbing, buckles, latch plates, retractors, anchorages, and guide loops. Replace any seat belts which do not work properly or are damaged.

#### **⚠ WARNING**

Be sure to inspect all seat belt assemblies after any collision. Any seat belt assembly which was in use during a collision (other than a very minor one) should be replaced, even if damage to the assembly is not obvious. Any seat belt assembly which was not in use during a collision should be replaced if it does not function properly, it is damaged in any way or the seat belt pretensioners were activated (that is, if the front air bags were activated).

### Child Restraint Systems



60G332S

### Infant restraint - rear seat only

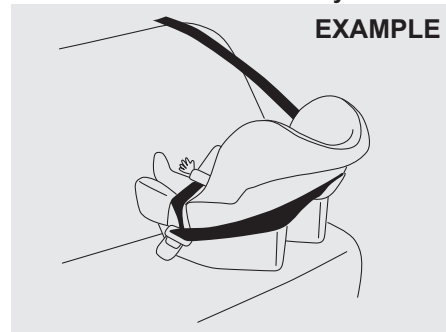

80JC007

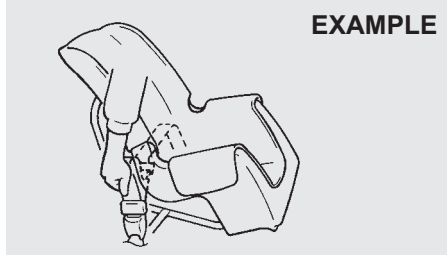
**Child restraint**

80JC016

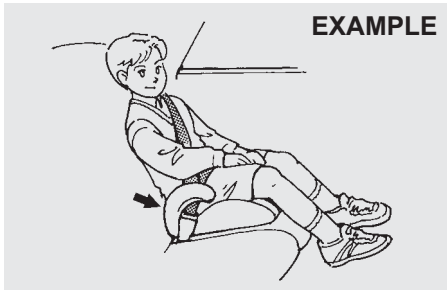
**Booster seat**

80JC008

MARUTI SUZUKI highly recommends that you use a child restraint system to restrain infants and small children. Many different types of child restraint systems are available; make sure that the restraint system you select meets applicable safety standards.

All child restraint systems are designed to be secured in vehicle seats by either seat

belts (lap belts or the lap portion of lap-shoulder belts). MARUTI SUZUKI recommends that child restraint systems be installed on the rear seat as per the Child Restraint System table in this section. According to accident statistics, children are safer when properly restrained in rear seating positions than in front seating positions.

**NOTE:**

Observe any statutory regulation about child restraints.



58MS030

**⚠ WARNING**

**Do not install a rear-facing child restraint in the front passenger's seat. If the passenger's front air bag inflates, a child in a rear-facing child restraint could be killed or severely injured. The back of a rear-facing child restraint would be too close to the inflating air bag.**

**⚠ WARNING**

**If you install a child restraint system in the rear seat, slide the front seat far enough forward so that the child's feet do not touch the front seatback. This will help avoid injury to the child in the event of an accident.**



65D608



65D609

## BEFORE DRIVING

### ⚠ WARNING

Children could be endangered in a crash if their child restraint systems are not properly secured in the vehicle. When installing a child restraint system, be sure to follow the instructions below. Be sure to secure the child in the restraint system according to the manufacturer's instructions.

### ⚠ WARNING

In an accident or sudden stop, the rear seat armrest (if equipped) could fall forward. If there is a child in a rear-facing child restraint in the rear center seating position, the falling armrest could injure the child. Do not install a rear-facing child restraint in the rear center seating position.

## Installation with Lap-Shoulder Seat Belts

### NOTICE

Before installing a child restraint system in the rear seat, raise the head restraint to the most upper position.

#### NOTE:

*If the most upper position head restraint interferes a child restraint system and prevents the child restraint system from being installed securely, remove the head restraint.*

*Stow the removed head restraint in the luggage compartment so it will not inconvenience the occupants.*

### ELR type belt

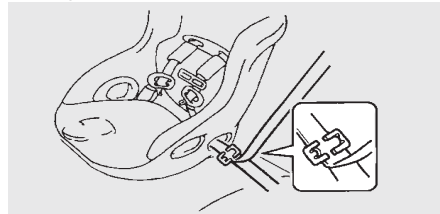

80JC021

Install your child restraint system according to the instructions provided by the child restraint system manufacturer.

Make sure that the seat belt is securely latched.

Try to move the child restraint system in all directions to make sure it is securely installed.

### Installation with a Lap Belt

#### EXAMPLE

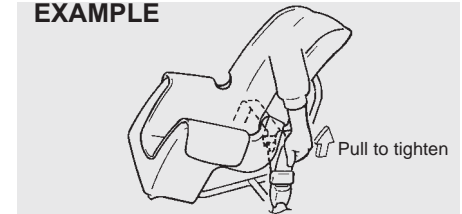

60G132

Install your child restraint system according to the instructions provided by the child restraint system manufacturer.

To lengthen or tighten the belt, refer to the "Lap-belt" item in this "Seat Belts and Child Restraint Systems" section. After making sure that the seat belt is securely latched, try moving the child restraint system in all directions, to make sure it is securely installed. If you need to tighten the belt, pull the free end of the webbing.

## Child Restraint System for India

### Child Restraint

The suitability of each passenger's seat position for carriage of children and fitting of child restraint system is shown in the table below. Whenever you carry children up to 12 years of age, properly use the child restraints which conform to AIS 072, the standard for child restraints, referring to the table.

MASS GROUP	Seating position (or other site)				
	Front Passenger	Rear Outboard	Rear Centre	Intermediate Outboard	Intermediate Centre
Group 0 Up to 10 kg	X	U	X	N.A.	N.A.
Group 0+ Up to 13 kg	X	U	X	N.A.	N.A.
Group I 9 to 18 kg	X	U	X	N.A.	N.A.
Group II 15 to 25 kg	X	U	X	N.A.	N.A.
Group III 22 to 36 kg	X	U	X	N.A.	N.A.

Key of letters to be inserted in the above table:

U =Suitable for 'universal' category restraints approved for use in this mass group

X =Seat position not suitable for children in this mass group

N.A = Seat position not available for children in this mass group.

NOTE: 'universal' is the category in the AIS 072.

: 'Outboard' indicates window side seat.

## BEFORE DRIVING

### Seat Belt Pretensioner System (if equipped)

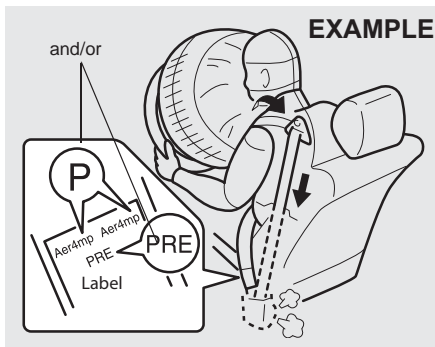

63J269

#### WARNING

This section of the owner's manual describes your Vehicle's SEAT BELT PRETENSIONER SYSTEM. Please read and follow ALL these instructions carefully to minimize your risk of severe injury or death.

To determine if your vehicle is equipped with a seat belt pretensioner system at the front seating positions, check the label on the front seat belt at the bottom part. If the letters "p" and/or "PRE" appear as illustrated, your vehicle is equipped with the seat belt pretensioner system. You can use

the pretensioner seat belts in the same manner as ordinary seat belts.

Read this section and the "Supplemental Restraint System (air bags)" section to learn more about the pretensioner system.

The seat belt pretensioner system works with the **SUPPLEMENTAL RESTRAINT SYSTEM (Air Bags)**. The crash sensors and the electronic controller of the air bag system also control the seat belt pretensioners. The pretensioners are triggered only when there is a frontal crash severe enough to trigger the air bags and the seat belts are fastened. For precautions and general information including servicing the pretensioner system, refer to the "Supplemental Restraint System (air bags)" section in addition to this "Seat Belt Pretensioner System" section, and follow all those precautions.

The pretensioner is located in each front seat belt retractor. The pretensioner tightens the seat belt so the belt fits the occupant's body more snugly in the event of a frontal crash. The retractors will remain locked after the pretensioners are activated. Upon activation, some noise will occur and some smoke may be released. These conditions are not harmful and do not indicate a fire in the vehicle.

The driver and all passengers must be properly restrained by wearing seat belts at all times, whether or not a pretensioner is equipped at their seating position, to

minimize the risk of severe injury or death in the event of a crash.

Sit fully back in the seat; sit up straight; do not lean forward or sideways. Adjust the belt so the lap portion of the belt is worn low across the pelvis, not across the waist. Please refer to the "Seat Adjustment" section and the instructions and precautions about the seat belts in this "Seat Belts and Child Restraint Systems" section for details on proper seat and seat belt adjustments. Please note that the pretensioners along with the air bags will activate in severe frontal collisions. They are not designed to activate in side impacts, rear impacts, roll-overs, or minor frontal collisions. The pretensioners can be activated only once. If the pretensioners are activated (that is, if the air bags are activated), have the pretensioner system serviced by an authorised Maruti Suzuki workshop as soon as possible.

If the air bag light on the instrument cluster does not blink or come on briefly when the ignition switch is turned to the "ON" position or the engine switch is pressed to change the ignition mode to ON, stays on for more than 10 seconds, or comes on while driving, the pretensioner system or the air bag system may not work properly. Have both systems inspected by an authorised Maruti Suzuki workshop as soon as possible.

Service on or around the pretensioner system components or wiring must be performed only by an authorised Maruti Suzuki workshop who is specially



trained. Improper service could result in unintended activation of pretensioners or could render the pretensioner inoperative. Either of these two conditions may result in personal injury.

To prevent damage or unintended activation of the pretensioners, be sure the battery is disconnected and the ignition switch has been in the "LOCK" position or the ignition mode has been LOCK (OFF) for at least 90 seconds before performing any electrical service work on your vehicle. Do not touch pretensioner system components or wiring. The wires are wrapped with yellow tape or yellow tubing, and the couplers are yellow. When scrapping your Vehicle, ask your authorised Maruti Suzuki workshop body repair shop, or scrap yard for assistance.

## BEFORE DRIVING

### Supplemental Restraint System (air bags) (if equipped)

#### **⚠ WARNING**

This section of the owner's manual describes the protection provided by your Vehicle's **SUPPLEMENTAL RESTRAINT SYSTEM** (air bags). Please read and follow **ALL** these instructions carefully to minimize your risk of severe injury or death in the event of a collision.

Your vehicle is equipped with a Supplemental Restraint System consisting of the following components in addition to a lap-shoulder belt at each seating position.

1. Driver's front air bag module (if equipped)
2. Front passenger's front air bag module (if equipped)
3. Seat belt pretensioners (if equipped)
4. Air bag controller
5. Forward crash sensor (if equipped)

#### EXAMPLE

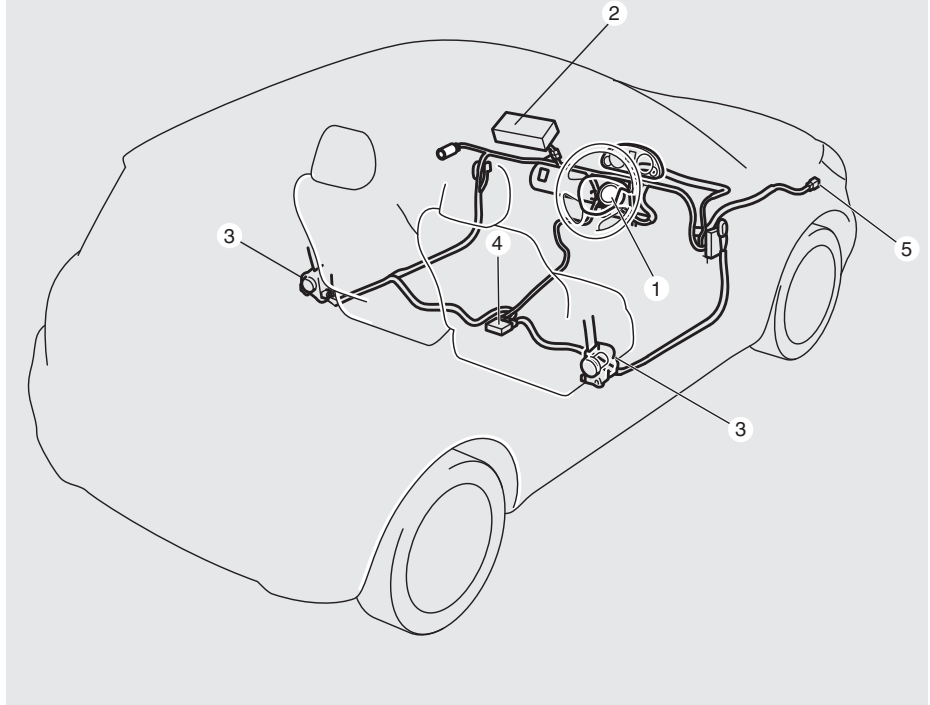

**⚠ WARNING**

An air bag supplements, or adds to, the crash protection offered by seat belts. The driver and all passengers must be properly restrained by wearing seat belts at all times, whether or not an air bag is mounted at their seating position, to minimize the risk of severe injury or death in the event of a crash.

**AIR BAG light**

63J030

If the AIR BAG light on the instrument cluster does not blink or come on when the ignition switch is first turned to the "ON" position, or the ignition mode is first changed to "ON", or the air bag light stays on, or comes on while driving, the air bag system (or the seat belt pretensioner system (if equipped)) may not work properly. Have the air bag system inspected by an authorised Maruti Suzuki workshop as soon as possible.

**Air bag symbol (if equipped) meaning****EXAMPLE**

72M00150

You may find this label on the sun visor.

**⚠ WARNING**

**NEVER use a rearward facing child restraint on a seat protected by an ACTIVE AIRBAG in front of it, DEATH or SERIOUS INJURY to the CHILD can occur.**

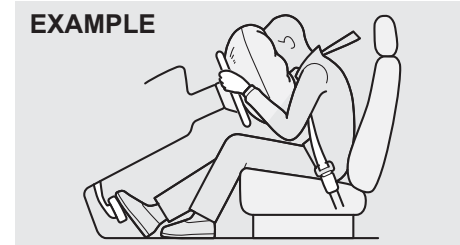
**Front Air Bags (if equipped)****EXAMPLE**

63J113

Front air bags are designed to inflate in severe frontal collisions when the ignition switch is in the "ON" position or the ignition mode is ON.

Front air bags are not designed to inflate in rear impacts, side impacts, rollovers or minor frontal collisions, since they would offer no protection in those types of accidents. Remember, since an air bag deploys only one time during an accident, seat belts are needed to restrain occupants from further movements during the accident.

Therefore, an air bag is NOT a substitute for seat belts. To maximize your protection, **ALWAYS WEAR YOUR SEAT BELTS**. Be aware that no system can prevent all possible injuries that may occur in an accident.

## BEFORE DRIVING

### Driver's front air bag (if equipped)

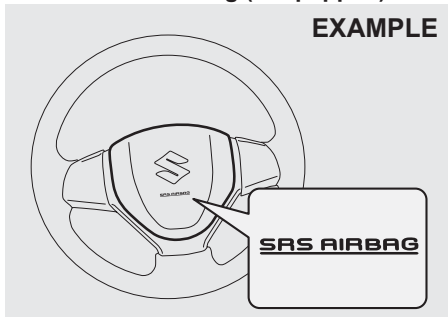

61M0020

### Front passenger's front air bag (if equipped)

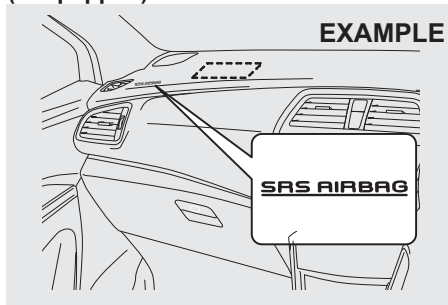

64MS117

The driver's front air bag is located behind the center pad of the steering wheel and the front passenger's front air bag is located behind the passenger's side of the dashboard.

The words "SRS AIRBAG" are molded into the air bag covers to identify the location of the air bags.



58MS030

**⚠ WARNING**

Do not install a rear-facing child restraint in the front passenger's seat. If the passenger's front air bag inflates, a child in a rear-facing child restraint could be killed or severely injured. The back of a rear-facing child restraint would be too close to the inflating air bag.

Please refer to the "Seat Belts and Child Restraint Systems" section in this section for details on securing your child.

### Conditions of front air bags deployment (inflation)



80J097

- In frontal collisions with a fixed wall that does not move or deform at vehicle speed of more than about 25 km/h (15 mph)

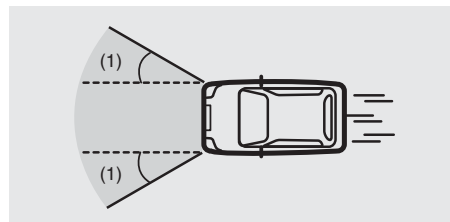

80J098E

- In collisions such as above at an angle of about 30 degrees (1) or less from the front

### Conditions of front air bags may inflate

Receiving a strong impact to the lower body of your vehicle, the front air bags will inflate in many cases.

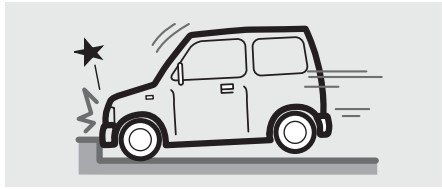

80J099

- Hitting a curb or medial strip

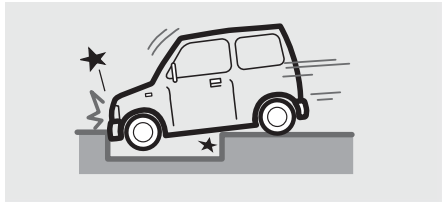

80J100E

- Falling into a deep hole or ditch

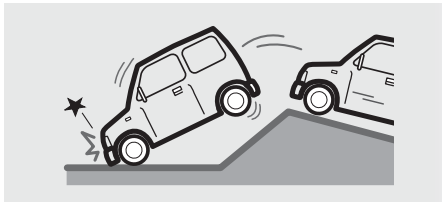

80J101

- Landing hard or falling

**Front air bags may inflate in a strong impact**

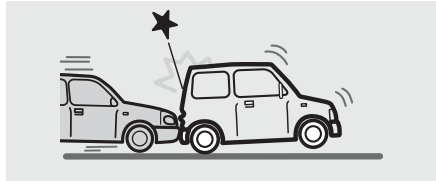

80J120

- Collision from the rear

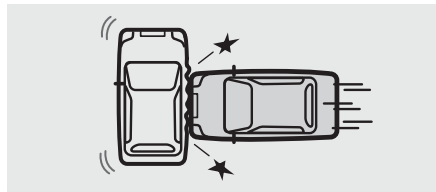

80J119

- Collision from the side



80J110

- Vehicle rollover

**Front air bags may not inflate**

The front air bags may not inflate when the impact is absorbed since the collision

object moved, vehicle body deformed, or collision angle was greater than about 30 degrees from the front.

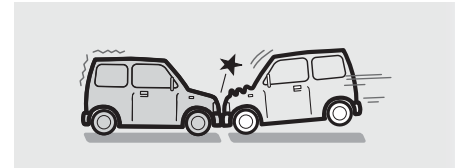

80J102

- Approximately 50 km/h (30 mph) or lower speed frontal collision to a stopped vehicle

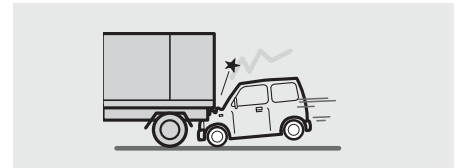

80J103

- Collision in which front of your vehicle goes under the bed of a truck etc.

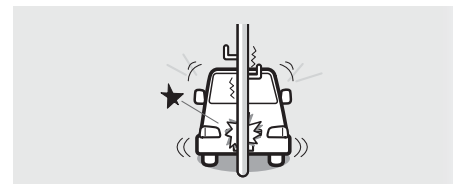

80J104

- Collision with a utility pole or stumpage

## BEFORE DRIVING

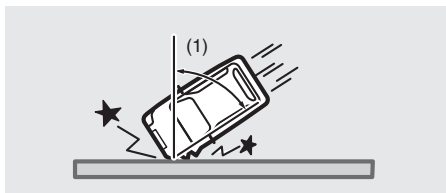

80J105E

- Collision with a fixed wall or guardrail at an angle of greater than about 30 degrees (1) from the front

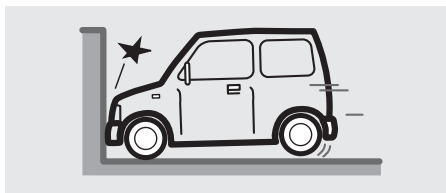

80J106

- In frontal collisions with a fixed wall that does not move or deform at vehicle speed of less than about 25 km/h (15 mph)

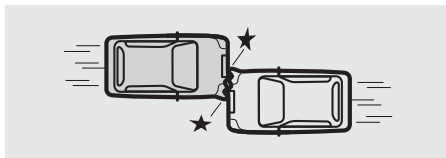

80J107

- Offset collision between two vehicles.

### How the System Works

In a frontal collision, the crash sensors will detect rapid deceleration, and if the controller judges that the deceleration represents a severe frontal crash, the controller will trigger the inflators. The inflators inflate the appropriate air bags with nitrogen or argon gas. The inflated air bags provide a cushion for your head and upper body. The air bag inflates and deflates so quickly that you may not even realize that it has activated. The air bag will neither hinder your view nor make it harder to exit the vehicle.

Air bags must inflate quickly and forcefully in order to reduce the chance of serious or fatal injuries. However, an unavoidable consequence of the quick inflation is that the air bag may irritate bare skin, such as the facial area against a front air bag. Also, upon inflation, a loud noise will occur and some powder and smoke will be released. These conditions are not harmful and do not indicate a fire in the vehicle. Be aware, however, that some air bag components may be hot for a while after inflation.

A seat belt helps keep you in the proper position for maximum protection when an air bag inflates. Adjust your seat as far back as possible while still maintaining control of the vehicle. Sit fully back in your seat; sit up straight; do not lean over the steering wheel or dashboard. Front occupants should not lean on or sleep against the door. Please refer to the "Front Seat" section and the "Seat Belts and Child Restraint Systems" section in this section for details on proper seat and seat belt adjustments.



65D610

### ⚠ WARNING

- The driver should not lean over the steering wheel. The front passenger should not rest his or her body against the dashboard, or otherwise get too close to the dashboard. In these situations, the out-of-position occupant would be too close to an inflating air bag, and may suffer severe injury.
- Do not attach any objects to, or place any objects over, the steering wheel or dashboard. Do not place any objects between the air bag and the driver or front passenger. These objects may interfere with air bag operation or may be propelled by the air bag in the event of a crash. Either of these conditions may cause severe injury.

Note that even though your vehicle may be moderately damaged in a collision, the collision may not have been severe enough to trigger the front air bags to inflate. If your vehicle sustains ANY front-end damage, have the air bag system inspected by an authorised Maruti Suzuki workshop to ensure it is in proper working order.

Your vehicle is equipped with a diagnostic module which records information about the air bag system if the air bags deploy in a crash. The module records information about overall system status, which sensors activated the deployment.

### **Servicing the air bag system**

If the air bags inflate, have the air bags and related components replaced by an authorised Maruti Suzuki workshop as soon as possible.

If your vehicle ever gets in deep water and the driver's floor is submerged, the air bag controller could be damaged. If it does, have the air bag system inspected by the authorised Maruti Suzuki workshop as soon as possible.

Special procedures are required for servicing or replacing an air bag. For that reason, only an authorised Maruti Suzuki workshop should be allowed to service or replace your air bags. Please remind any-one who services your vehicle that it has air bags.

Service on or around air bag components or wiring must be performed only by an authorised Maruti Suzuki workshop. Improper service could result in unintended air bag deployment or could render the air

bag inoperative. Either of these two conditions may result in severe injury.

To prevent damage or unintended inflation of the air bag system, be sure the battery is disconnected and the ignition switch has been in the "LOCK" position or the ignition mode has been LOCK (OFF) for at least 90 seconds before performing any electrical service work on your Vehicle. Do not touch air bag system components or wires. The wires are wrapped with yellow tape or yellow tubing, and the couplers are yellow for easy identification.

Scraping a vehicle that has an uninflated air bag can be hazardous. Ask your authorised Maruti Suzuki body repair shop or scrap yard for help with disposal.

## BEFORE DRIVING

### Instrument Cluster

1. Speedometer
2. Tachometer
3. Fuel gauge
4. Temperature gauge
5. Information display
6. Warning and indicator lights

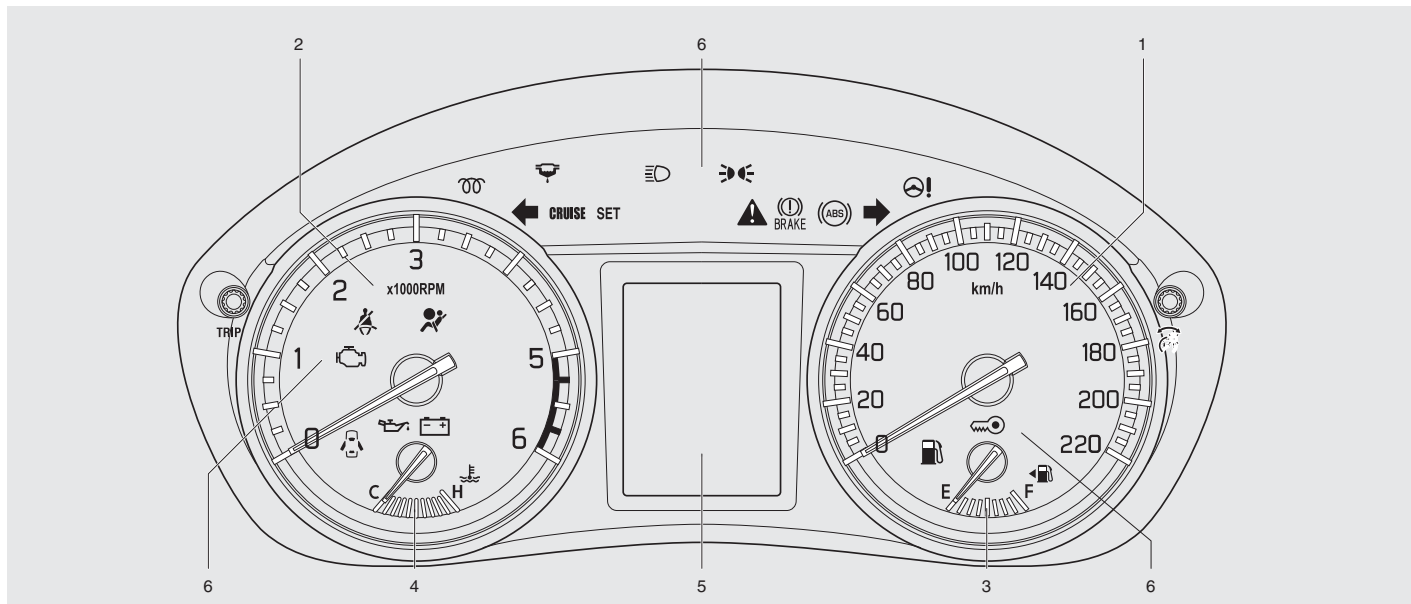

64MS166



## Speedometer

The speedometer indicates vehicle speed.

## Tachometer

The tachometer indicates engine speed in revolutions per minute.

### NOTICE

Never drive the vehicle with the engine revving in the red zone or severe engine damage can result. Keep the engine speed below the red zone even when downshifting to a lower gear position. Refer to “Downshifting maximum allowable speeds” in the “OPERATING YOUR VEHICLE” section.

## Fuel Gauge

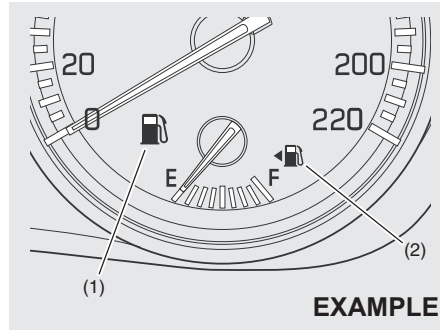

61MM0A154

When the ignition switch is in the “ON” position or the ignition mode is “ON”, this gauge gives an approximate indication of the amount of fuel in the fuel tank. “F” stands for full and “E” stands for empty.

If the indicator gets off the graduation of “E” (not character “E”), refill the tank as soon as possible.

### NOTE:

*The indicator moves a little depending on road conditions (for example, slope or curve) and driving conditions because of fuel moving in the tank.*

If the low fuel warning light (1) comes on, fill the fuel tank immediately.

Refer to “Low Fuel Warning Light” in “Warning and Indicator Lights” in this section for details.

The mark (2) indicates that the fuel filler lid is located on the left side of the vehicle.

## BEFORE DRIVING

### Temperature Gauge

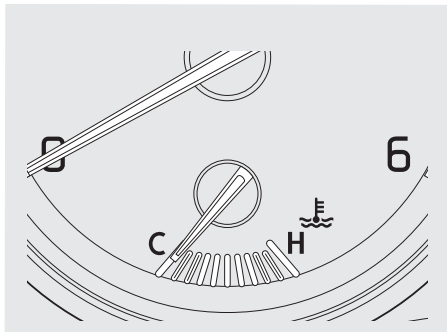

64MS046

When the ignition switch is in the “ON” position or the ignition mode is “ON”, this gauge indicates the engine coolant temperature. Under normal driving conditions, the indicator should stay within the normal, acceptable temperature range between “H” and “C”. If the indicator approaches “H”, overheating is indicated. Follow the instructions for engine overheating in the “EMERGENCY SERVICE” section.

#### NOTICE

**Continuing to drive the vehicle when engine overheating is indicated can result in severe engine damage.**

### Brightness Control

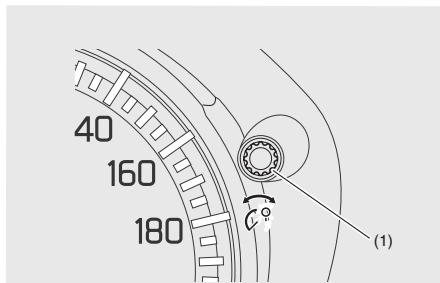

61MMA156

When the ignition switch is turned to the “ON” position or the engine switch is pressed to change the ignition mode to “ON”, the instrument cluster lights come on.

Your vehicle has a system to automatically dim the brightness of the instrument panel lights when the position lights or headlights are on.

You can change the brightness of the instrument panel lights regardless of whether the position lights or headlights are off or on.

To increase the brightness of the instrument panel lights, turn the indicator selector knob (1) clockwise.

To reduce the brightness of the instrument panel lights, turn the indicator selector knob (1) counterclockwise.

#### ⚠ WARNING

**If you attempt to adjust the brightness of the instrument panel lights while driving, you could lose control of the vehicle.**

**Do not attempt to adjust the brightness of the instrument panel lights while driving.**

#### NOTE:

- If you do not turn the knob for more than 5 seconds while activating the brightness control, the brightness control display will be canceled automatically.
- When you reconnect the battery, the brightness of the instrument panel lights will be reinitialized. Readjust the brightness according to your preference.

#### NOTE:

*If you select the high brightness level when the position lights or headlights are on, the instrument panel lights are not dimmed.*

## Information Display

The information display is shown when the ignition switch is in the "ON" position or the ignition mode is ON.

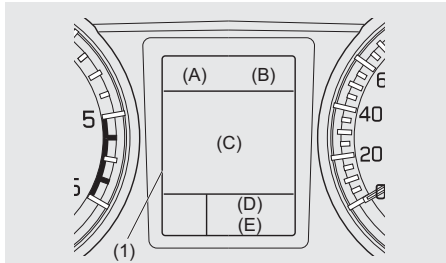

64MS183

(1) Information display

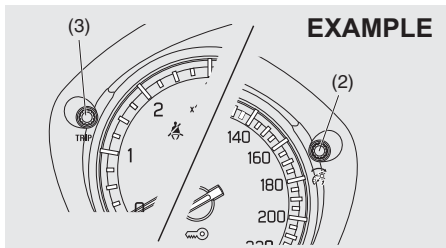

64MS184

- (2) Indicator selector knob  
(3) Trip meter selector knob

The information display shows the following information.

### Display (A)

Clock

### Display (B)

Thermometer

### Display (C)

Warning and indicator messages /  
Fuel consumption / Driving range /  
Average speed

### Display (D)

Trip meter

### Display (E)

Odometer



64MS181

When the ignition switch is turned to the "ON" position or the engine switch is pressed to change the ignition mode to ON, the message shown in the above illustration will appear on the display for several seconds.

Some warning and indicator messages may appear on the display when the ignition switch is in the "ACC" or "LOCK" position, or the ignition mode is ACC or LOCK (OFF).

## Clock

The display (A) shows the time.

To set the clock, follow the "Setting mode" instructions in this section.

## Thermometer

The display (B) shows the thermometer.

The thermometer indicates the outside temperature.



61MM0A160

If the outside temperature nears freezing, the message shown in the above illustration will appear on the display.

### NOTE:

*The outside temperature indication is not the actual outside temperature when driving at low speed, or when stopped.*

## BEFORE DRIVING

### Fuel Consumption / Driving Range / Average Speed

When there are no warning or indicator messages on the display (C), you can select one of the following indications to appear on the display: instantaneous fuel consumption, average fuel consumption, driving range, average speed or no indication.

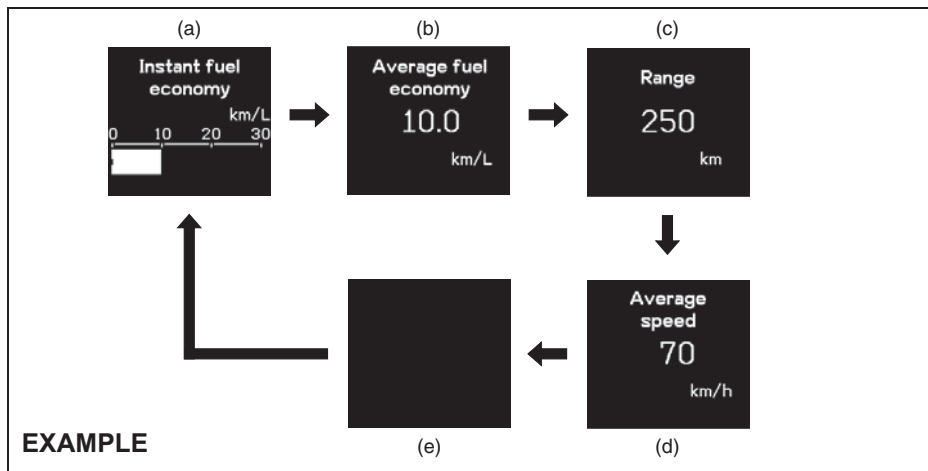

#### NOTE:

The value of fuel consumption, driving range and average speed shown in the display are affected by conditions such as the following;

- road condition
- surrounding traffic condition
- driving condition
- vehicle condition
- a malfunction which causes the malfunction indicator light to come on or blink

**EXAMPLE**

64MS058

- (a) Instantaneous fuel consumption
- (b) Average fuel consumption
- (c) Driving range
- (d) Average speed
- (e) No indication

To switch the display indication, push the indicator selector knob (2) quickly.

### Instantaneous fuel consumption

The display shows instantaneous fuel consumption with a bar graph only when the vehicle is moving.

#### NOTE:

- *The display does not show the bar graph unless the vehicle is moving.*
- *Depending on the vehicle's specification, the fuel consumption units of initial setting are indicated as L/100km, km/L or MPG.*
- *For "L/100km" or "km/L" setting, the indicated maximum value of instantaneous fuel consumption is 30. No more than 30 will be indicated on the display even if the actual instantaneous fuel consumption is higher.*
- *For "MPG" setting, the indicated maximum value of instantaneous fuel consumption is 80. No more than 80 will be indicated on the display even if the actual instantaneous fuel consumption is higher.*
- *The indication on the display may be delayed if fuel consumption is greatly affected by driving conditions.*
- *The display shows estimated values. Indications may not be the same as actual values.*

### Average fuel consumption

If you selected average fuel consumption the last time you drove the vehicle, the display shows the last value of average fuel consumption from previous driving when the ignition switch is turned to the "ON"

position or the engine switch is pressed to change the ignition mode to "ON". Unless you reset the value of average fuel consumption, the display indicates the value of average fuel consumption which includes average fuel consumption during previous driving.

#### NOTE:

*When you reconnect the negative (-) terminal to the battery, the value of average fuel consumption will be shown after driving for a period of time.*

You can select when the value of average fuel consumption is reset from among the following three methods;

- *Reset after refuel: the value of average fuel consumption will be reset automatically by refueling.*
- *Reset with trip A: the value of average fuel consumption will be reset automatically by resetting trip meter A.*
- *Reset manually: the value of average fuel consumption will be reset by pushing and holding the indicator selector knob (2) when the display indicates the average fuel consumption.*

To change when the value of average fuel consumption is reset, refer to "Setting Mode" later in this section.

#### NOTE:

*If you add only a small amount of fuel when you select "Reset after refuel", the average fuel consumption value may not be reset.*

### Driving range

If you selected driving range the last time you drove the vehicle, the display indicates "---" for a few seconds and then indicates the current driving range when the ignition switch is turned to the "ON" position or the engine switch is pressed to change the ignition mode to ON.

The driving range shown in the display is the approximate distance you can drive until the fuel gauge indicates "E", based on current driving conditions.

When the low fuel warning light comes on, the display "---" will appear. If the low fuel warning light comes on, fill the fuel tank immediately.

As the driving range after refueling is calculated based on the most recent driving condition, the value is different each time you refuel.

#### NOTE:

- *If you refuel when the ignition switch is in the "ON" position or the ignition mode is "ON", the driving range may not indicate the correct value.*
- *When you reconnect the negative (-) terminal to the battery, the value of driving range will be shown after driving for a period of time.*

## BEFORE DRIVING

### Average Speed

If you selected average speed the last time you drove the vehicle, the display indicates the last value of average speed from previous driving when the ignition switch is turned to the "ON" position or the engine switch is pressed to change the ignition mode to "ON". Unless you reset the value of average speed, the display indicates the value of average speed which includes average speed during previous driving.

To reset the value of average speed, push and hold the indicator selector knob (2) for about 2 seconds when the display indicates an average speed. The display shows "---" and then indicates a new average speed after driving for a short time.

#### NOTE:

*When you reconnect the negative (-) terminal to the battery, the value of average speed will be shown after driving for a period of time.*

### Trip Meter

The display (D) shows the trip meter.

The trip meter can be used to measure the distance traveled on short trips or between fuel stops.

You can use the trip meter A or trip meter B independently.

To reset the trip meter to zero, push and hold the trip meter selector knob (3) for about 2 seconds when the display shows the trip meter.

### Odometer

The display (E) shows the odometer.

The odometer records the total distance the vehicle has been driven.

#### NOTICE

**Keep track of your odometer reading and check the maintenance schedule regularly for required services. Increased wear or damage to certain parts can result from failure to perform required services at the proper mileage intervals.**

### Setting Mode

When the ignition switch is in the "ON" position or the ignition mode is ON and the vehicle is stationary, you can enter the setting mode of the information display by pushing and holding the indicator selector knob (2) for more than 3 seconds.

- To select the setting that you want to change, turn the indicator selector knob (2) left or right.
- To change the setting, push the indicator selector knob (2).
- To exit the setting mode, select "Back" and push the indicator selector knob (2).

#### EXAMPLE

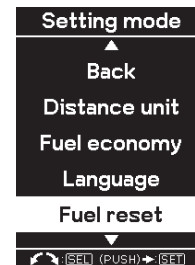

61MM0A161

#### NOTE:

*The currently selected setting item is indicated enclosed by a frame.*

#### NOTE:

- *If you push and hold the indicator selector knob (2) to enter the setting mode when the display (D) shows average fuel consumption or average speed, the value will be reset simultaneously. If you do not want to reset the value, push the indicator selector knob quickly to switch the indication of the display.*
- *If you turn the ignition switch, press the engine switch or start to move the vehicle when the display is in the setting mode, the setting mode will be canceled automatically.*

**Distance unit  
(Odo/trip meter distance units setting)**

You can change the units odo/trip meter distance is displayed in.

**NOTE:**

*When you change the units odo/trip meter distance is displayed in, the trip meter will be reset automatically.*

**Fuel economy  
(Fuel consumption units setting)**

You can change the units that fuel consumption is displayed in.

**Language**

You can change the language of the information display.

**Fuel reset (Average fuel consumption reset setting)**

You can change when the value of average fuel consumption is reset.

**Temperature  
(Temperature units setting)**

You can change the units that temperature is displayed in.

**NOTE:**

*When you change the units that temperature is displayed in, the automatic heating and air conditioning system (if equipped) temperature display units will be changed automatically.*

**Set Sensors  
(Parking sensors (if equipped) setting)**

The parking sensor can be switched between the normal mode and trailer mode.

**Clock setting**

- To change the hour indication, turn the indicator selector knob (2) left or right repeatedly when the hour indication appears as reversed color. To change the hour indication quickly, turn and hold the indicator selector knob (2). To set the hour indication, push the indicator selector knob (2) and the minute indication appears as reversed color.
- To change the minute indication, turn the indicator selector knob (2) left or right repeatedly when the minute indication appears as reversed color. To change the minute indication quickly, turn and hold the indicator selector knob (2). To set the minute indication, push the indicator selector knob (2).

You can also switch the time indication between 12-hour and 24-hour format.

**Door Lock (Door lock setting)**

- **Door Unlock**
- **All Doors:**  
Unlock all doors by turning the key, or operating the keyless entry system transmitter, keyless push start system remote controller or request switch once
- **Driver Door:**  
Unlock all doors by turning the key, or operating the keyless entry system transmitter, keyless push start system remote controller or request switch twice (default setting)
- **Auto Lock**
- **Manual Lock:**  
Disable the automatic door locking function
- **Speed Syncro:**  
Lock all doors when the vehicle speed reaches 15 km/h (default setting)
- **Auto Unlock**
- **Syncro Off:**  
Disable the automatic door unlocking function (default setting for the vehicle with the keyless push start system)
- **IG-OFF Sync:**  
Unlock all doors when the key is pulled out from the ignition switch or the engine switch is pressed to change the ignition mode to LOCK (OFF) (default setting for the vehicle without the keyless push start system)

## BEFORE DRIVING

---

- **Alarm**

You can turn off or on the siren sound when the door(s) is (are) locked or unlocked.

- **Lights (Light setting)**

- **Foot Lights (Foot well lights setting) (if equipped)**

The foot well lights can be programmed for interlocked operation with either lighting control or door operation and for no lighting. (default setting is door operation)

- **Lane Change (Turn signal lights setting)**

The turn signal and its indicator can be set whether they flash three times even if you return the turn signal control lever immediately after moving it. (default setting is enabled state)

- **Anti theft**

- **(Security system (if equipped) setting)**

- **Mode Select**

You can switch the security system from the enabled state to the disabled state, and vice versa.

The state of the security system is shown on the information display as follows:

- Mode A: Disabled state
- Mode D: Enabled state (default setting)

- **Shock Sensor**

You can switch the shock sensor from the disabled state to the enabled state, and vice versa. (default setting is disabled state)

- **Shock Sens P**

You can adjust the pre-warning sensitivity of shock sensor. (default setting level is 14)

- **Shock Sens F**

You can adjust the full blast warning sensitivity of shock sensor. (default setting level is 9)

- **Default (initialization setting)**

If you select "Yes" and push the indicator selector knob (2), all settings will be reinitialized.

## Warning and Indicator Messages

The display shows warning and indicator messages to let you know about certain vehicle problems.

A tone may also sound to alert you.

If warning and indicator messages appear on the display, follow the messages.

### Master warning indicator light



78K049



When the display shows warning and indicator messages, the master warning indicator light may also blink.

#### NOTE:



- *When the problem that causes a message to appear is corrected, the message will disappear.*
- *If a message is displayed, and other problems requiring a message occur, the message for each of the problems will be alternately displayed about every 5 seconds.*
- *When you push and hold the indicator selector knob (2) for about 2 seconds while a message is displayed, the message will disappear temporarily. If the problem that caused the message is not corrected, the message will appear again after 5 seconds.*

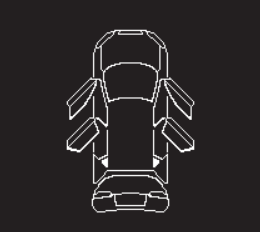





Warning and indicator messages

Warning and Indicator Message	Master Warning Indicator Light	Sound	Cause and Remedy
 <p>61MM0A162</p>	<p>Blinks (only while vehicle is in motion)</p> 	<p>Beep (one time from interior buzzer; only while vehicle is in motion)</p>	<p>A door or tailgate is not properly closed. Stop in a safe place and close the door or tailgate properly. (#1)</p>
 <p>64MS182</p>			

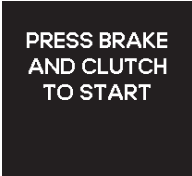

## BEFORE DRIVING



Warning and Indicator Message	Master Warning Indicator Light	Sound	Cause and Remedy
<p>Keyless Push Start System</p>  <p>61MM0A163</p>	Off	Off	This message is displayed when the ACC position is selected as the power supply position. (#1)
<p>Keyless Push Start System</p>  <p>61MM0A164</p>	Off	Off	The clutch pedal is depressed. Press the engine switch to start the engine.

(#1) This message will disappear for a while even if the problem that caused the message to appear is not corrected.

Warning and Indicator Message	Master Warning Indicator Light	Sound	Cause and Remedy
<p>Keyless Push Start System</p>  <p>61MM0A166</p>	<p>Off</p>	<p>Off</p>	<p>The engine switch is pressed without depressing the brake and clutch pedals. Try again as instructed by the message.</p> <div style="border: 1px solid black; padding: 5px;"> <p style="text-align: center;"><b>⚠ WARNING</b></p> <p><b>Engine can be started only after depressing the clutch pedal. However, before depressing the clutch pedal make sure that the transaxle is in Neutral and brake pedal is depressed.</b></p> </div>
<p>Keyless Push Start System</p>  <p>61MM0A168</p>	<p>Blinks</p> 	<p>Beep (one time from interior buzzer)</p>	<p>There is a problem with the steering lock system. Have your vehicle inspected by an authorised Maruti Suzuki workshop.</p>
<p>Keyless Push Start System</p>  <p>61MM0A168</p>	<p>Blinks</p> 	<p>Beep (one time from interior buzzer)</p>	<p>There is a problem with the steering lock system. Have your vehicle inspected by an authorised Maruti Suzuki workshop.</p>



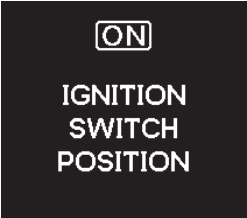

## BEFORE DRIVING

Warning and Indicator Message	Master Warning Indicator Light	Sound	Cause and Remedy
<p>Keyless Push Start System</p> <div data-bbox="181 259 373 500" style="background-color: black; color: white; padding: 10px; text-align: center;">   <b>KEY FOB NOT DETECTED</b> </div> <p style="text-align: right; font-size: small;">61MM0A170</p> <div data-bbox="185 551 376 771" style="background-color: black; color: white; padding: 10px; text-align: center;">   <b>PLACE KEY FOB ON START SWITCH</b> </div> <p style="text-align: right; font-size: small;">61MM0A171</p>	<p>Blinks</p> 	<p>Series of beeps under certain conditions (for about 2 seconds from exterior and/or interior buzzers)</p>	<p>The remote controller may be outside the vehicle or its battery may have become discharged. Locate the remote controller or touch the engine switch with the remote controller. If the message still appears, replace the remote controller battery.</p>





Warning and Indicator Message	Master Warning Indicator Light	Sound	Cause and Remedy
 <p style="text-align: right; font-size: small;">61MM0A172</p>	<p>Blinks</p> 	<p>Continuous beep (from interior buzzer)</p>	<p>The headlights and/or the position lights are left on. Turn them off.</p>
<p>Keyless Push Start System</p>  <p style="text-align: right; font-size: small;">61MM0A173</p>	<p>Off</p>	<p>Off</p>	<p>This message is displayed when the ON position is selected as the power supply position. (#1)</p>

(#1) This message will disappear for a while even if the problem that caused the message to appear is not corrected.

## BEFORE DRIVING

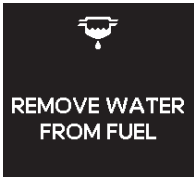
Warning and Indicator Message	Master Warning Indicator Light	Sound	Cause and Remedy
 <p>61MM0A176</p>	Off	Off	The road may be icy. Drive very carefully. (#1)
<p>Keyless Push Start System</p>  <p>61MM0A177</p>	Off	Off	The remote controller battery is about to become flat. Replace the battery. (#1)
 <p>61MM0A225</p>	<p>Blinks</p> 	Beep (one time from interior buzzer)	There may be a problem with the fuel filter. Have your vehicle inspected by an authorized Maruti Suzuki workshop.

(#1) This message will disappear for a while even if the problem that caused the message to appear is not corrected.

Warning and Indicator Message	Master Warning Indicator Light	Sound	Cause and Remedy
 <p>61MM0A226</p>	<p>Blinks</p> 	<p>Beep (one time from interior buzzer)</p>	<p>There is a possibility to have water in the fuel filter. Have your vehicle inspected by an authorized Maruti Suzuki workshop.</p>
 <p>61MM0A180</p>	<p>Blinks</p> 	<p>Beep (one time from interior buzzer)</p>	<p>If this message is displayed, have your vehicle inspected by an authorized Maruti Suzuki workshop.</p>

**NOTE:**

*If your vehicle is equipped with a parking sensor system, the information display also indicates warning and indicator messages related to the system. For information on these messages, refer to "Parking Sensors" in the "OPERATING YOUR VEHICLE" section.*

## BEFORE DRIVING

### Warning and Indicator Lights

#### NOTE:

If warning and indicator lights blink or come on, the corresponding messages may be shown on the information display.

### Brake System Warning Light



Three different types of operations exist depending on the vehicle's specification.

- 1) The light comes on briefly when the ignition switch is turned to the "ON" position or the engine switch is pressed to change the ignition mode to "ON".
- 2) The light comes on when the parking brake is engaged with the ignition switch in the "ON" position or the ignition mode "ON".
- 3) The light comes on when under either or both of above two conditions.

The light also comes on when the fluid in the brake fluid reservoir falls below the specified level.

The light should go out after starting the engine and fully releasing the parking brake, if the fluid level in the brake fluid reservoir is adequate.

If your vehicle is equipped with the ABS, the brake system warning light also comes on together with the ABS warning light when the rear brake force control function

(proportioning valve function) of the ABS system fails.

If the brake system warning light comes on while you are driving the vehicle, it may mean that there is something wrong with the vehicle's brake system. If this happens, you should:

- 1) Pull off the road and stop carefully.

#### **WARNING**

**Remember that stopping distance may be longer, you may have to push harder on the pedal, and the pedal may go down farther than normal.**

- 2) Test the brakes by carefully starting and stopping on the shoulder of the road.
- 3) If you determine that it is safe, drive cautiously at low speed to the nearest authorised Maruti Suzuki workshop for repairs, or
- 4) Have the vehicle towed to the nearest authorised Maruti Suzuki workshop for repairs.



**⚠ WARNING**

If any of the following conditions occur, you should immediately ask your authorised Maruti Suzuki workshop to inspect the brake system.

- If the brake system warning light does not go out after the engine has been started and the parking brake has been fully released.
- If the brake system warning light does not come on when the ignition switch is turned to the “ON” position or the engine switch is pressed to change the ignition mode to “ON”.
- If the brake system warning light comes on at any time during vehicle operation.

**NOTE:**

*Because the brake system is self-adjusting, the fluid level will drop as the brake pads become worn. Replenishing the brake fluid reservoir is considered normal periodic maintenance.*

**NOTE:**

*(Parking Brake Reminder Buzzer)*

*A buzzer sounds intermittently to remind you to release the parking brake if you start the vehicle without releasing the parking brake. Make sure that the parking brake is fully released and the brake system warning light turns off.*

### Anti-Lock Brake System (ABS) Warning Light (if equipped)



65D529

When the ignition switch is turned to the “ON” position or the engine switch is pressed to change the ignition mode to “ON”, the light comes on briefly so you can check that the light is working.

If the light stays on, or comes on when driving, there may be something wrong with the ABS.

If this happens:

- 1) Pull off the road and stop carefully.
- 2) Turn the ignition switch to “LOCK” or change the ignition mode to “LOCK” (OFF) by pressing the engine switch and then start the engine again.

If the warning light comes on briefly then turns off, the system is normal. If the warning light still stays on.

If the light and the brake system warning light stay on, or come on simultaneously when driving, your ABS system is equipped with the rear brake force control function (proportioning valve function) and

there may be something wrong with both the rear brake force control function and anti-lock function of the ABS system.

If one of these happens, have the system inspected by your authorised Maruti Suzuki workshop.

If the ABS becomes inoperative, the brake system will function as an ordinary brake system that does not have this ABS system.

For details of ABS system, refer to “Anti-Lock Brake System (ABS)” in the “OPERATING YOUR VEHICLE” section.

## BEFORE DRIVING

### Oil Pressure Light

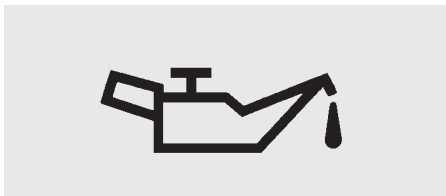

This light comes on when the ignition switch is turned to the “ON” position or the engine switch is pressed to change the ignition mode to “ON”, and goes out when the engine is started. The light will come on and remain on if there is insufficient oil pressure. If the light comes on when driving, pull off the road as soon as you can and stop the engine.

Check the oil level and add oil if necessary. If there is enough oil, the lubrication system should be inspected by your authorised Maruti Suzuki workshop before you drive the vehicle again.

#### **NOTICE**

- If you operate the engine with this light on, severe engine damage can result.
- Do not rely on the oil pressure light to indicate the need to add oil. Be sure to periodically check the engine oil level.

### Charging Light

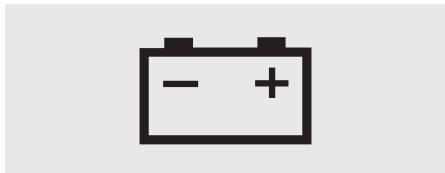

50G052

This light comes on when the ignition switch is turned to the “ON” position or the engine switch is pressed to change the ignition mode to “ON”, and goes out when the engine is started. The light will come on and remain on if there is something wrong with the battery charging system. If the light comes on when the engine is running, the charging system should be inspected immediately by your authorised Maruti Suzuki workshop.

### Driver's Seat Belt Reminder Light



60G049

When the driver doesn't buckle his or her seat belt, this light will come on and/or blink. For details about the seat belt reminder, refer to “**Seat Belts and Child Restraint Systems**” in this section.

**Air Bag Light**

63J030

This light blinks or comes on for several seconds when the ignition switch is turned to the “ON” position or the engine switch is pressed to change the ignition mode to “ON” so you can check if the light is working.

The light will come on and stay on if there is a problem in the air bag system or the seat belt pretensioner system (if equipped).

**⚠ WARNING**

**If the AIR BAG light does not blink or come on briefly when the ignition switch is turned to the “ON” position or the engine switch is pressed to change the ignition mode to ON, stays on for more than 10 seconds, or comes on while driving, the air bag system or the seat belt pretensioner system (if equipped) may not work properly. Have both systems inspected by an authorized Maruti Suzuki workshop.**

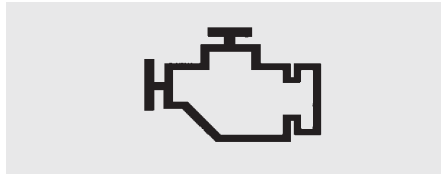
**Malfunction Indicator Light**

65D530

Your vehicle has a computer-controlled emission control system. A malfunction indicator light is provided on the instrument panel to indicate when it is necessary to have the emission control system serviced. The malfunction indicator light comes on when the ignition switch is turned to the “ON” position or the engine switch is pressed to change the ignition mode to “ON” to let you know the light is working and goes out when the engine is started.

If the malfunction indicator light comes on or blinks when the engine is running, there is a damage in the emission control system.

Bring the vehicle to your authorised Maruti Suzuki workshop to have the damage fixed.

**NOTICE**

**Continuing to drive the vehicle when the malfunction indicator light is on or blinking can cause permanent damage to the vehicle’s emission control system, and can affect fuel economy and driveability.**

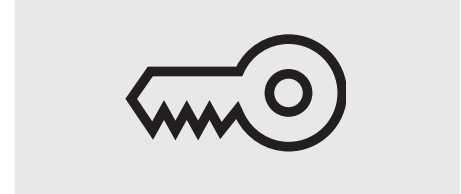
**Immobilizer/Keyless Push Start System Warning Light**

80JM122

When the ignition switch is turned to the “ON” position or the engine switch is pressed to change the ignition mode to ON, the light comes on briefly so you can check that the light is working. If this light stays on, there is a problem with the system. Ask your authorised Maruti Suzuki workshop to have the system inspected.

## BEFORE DRIVING

---

### Open Door Warning Light



54G391

This light remains on until all doors (including the tailgate) are completely closed.

If any door (including the tailgate) is open when the vehicle is moving, a ding sounds to remind you to close all doors completely.

### Low Fuel Warning Light



54G343

If this light comes on, fill the fuel tank immediately.

When this light comes on, a ding sounds once to remind you to fill the fuel.

If you do not fill the fuel, a ding sounds every time when the ignition switch is turned to the "ON" position or the engine switch is pressed to change the ignition mode to ON.

**NOTE:**

*The activation point of this light varies depending on road conditions (for example, slope or curve) and driving conditions because of fuel moving in the tank.*

### Electric Power Steering Light



79J039

This light comes on when the ignition switch is turned to the "ON" position or the engine switch is pressed to change the ignition mode to ON, and goes out when the engine is started.

If this light comes on or blinks while driving, the power steering system may not work properly. Have the system inspected by your authorised Maruti Suzuki workshop.

**NOTE:**

*While parking or driving at very low speed greater steering effort is required. This is not a malfunction of the steering system but power steering control system limiting power assist in order to prevent it from over heating.*

- *The steering wheel is operated very often.*
- *The steering wheel is kept in a fully turned position for a long while.*

*When the power steering control system cools down, the power steering system is restored back to the original condition.*

However, repeating these operations could cause damage to the power steering system.

**NOTE:**

If the power steering system does not work properly, you will feel heavier to steer but you still will be able to steer.

**NOTE:**

If the steering is operated, you may hear a noise. This is normal and indicates that the power steering system works properly.

**“CRUISE” Indicator Light  
(if equipped)**

A rectangular box with a light gray background containing the word "CRUISE" in large, bold, black, sans-serif capital letters.

**CRUISE**

52D113

When the cruise control system is on, this light will be on.

**“SET” Indicator Light (if equipped)**

A rectangular box with a light gray background containing the word "SET" in large, bold, black, sans-serif capital letters.

**SET**

65D474

When a cruising speed of the cruise control is set, this light will be on.

**Turn Signal Indicators**



50G055

When you turn on the left or right turn signals, the corresponding green arrow on the instrument panel will flash along with the respective turn signal lights. When you turn on the hazard warning switch, both arrows will flash along with all of the turn signal lights.

## BEFORE DRIVING

---

### Main Beam (high beam) Indicator Light



50G056

This indicator comes on when headlight main beams (high beams) are turned on.

### Illumination Indicator Light

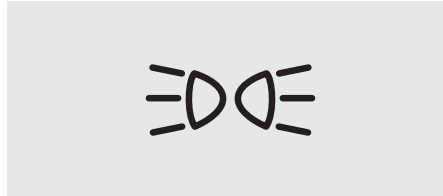

64J045

This indicator light comes on while the position lights, tail light and/or the headlights are on.

### Glow Plug Indicator Light



60A543

If the coolant temperature is cool enough, this light comes on when the ignition switch is turned to the "ON" position or the engine switch is pressed to change the ignition mode to ON and goes out when the glow plug is heated enough for engine starting.

**Fuel Filter Warning Light**

60A541

This light comes on for several seconds when the ignition switch is turned to the "ON" position or the engine switch is pressed to change the ignition mode to ON so you can check that light is working. If the light comes on when driving, there is a possibility to have water in the fuel filter. Drain water as soon as possible. Have your vehicle inspected by an authorised Maruti Suzuki workshop. For details of draining water, refer to "Fuel Filter" in the "INSPECTION AND MAINTENANCE" section.

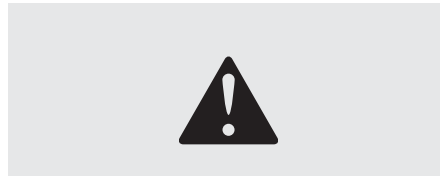
**Master Warning Indicator Light**

78K049

When the information display shows warning and indicator messages, this indicator light may also blink. For details, refer to "Information Display" in this section.

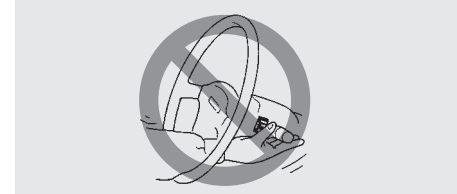
**Lighting Control Lever**

65D611

**⚠ WARNING**

**To avoid possible injury, do not operate controls by reaching through the steering wheel.**

## BEFORE DRIVING

### Lighting Operation

#### EXAMPLE

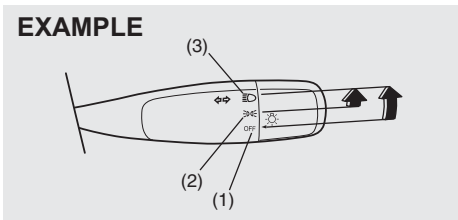

60MK011

To turn the lights on or off, twist the knob on the end of the lever. There are three positions:

#### OFF (1)

All lights are off.

#### ☰ (2)

Front position lights, tail lights, license plate light and instrument lights are on, but headlights are off.

#### ☰ (3)

Front position lights, tail lights, license plate light, instrument lights and headlights are on.

#### EXAMPLE

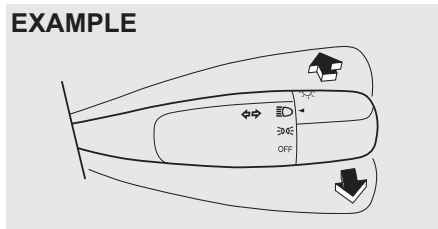

60MK012

With the headlights on, push the lever forward to switch to the high beams (main beams) or pull the lever toward you to switch to the low beams. When the high beams (main beams) are on, a light on the instrument panel will come on. To momentarily activate the high beams (main beams) as a passing signal, pull the lever slightly toward you and release it when you have completed the signal.

### Automatic Lights Operation (if equipped)

#### EXAMPLE

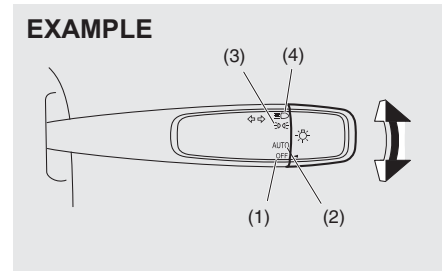

64MS059

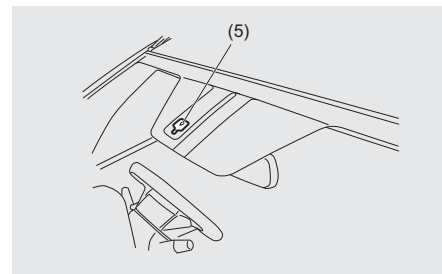

64MS060

Your vehicle's lighting system is controlled by two main systems: the Lighting switch and the Auto-On Headlight System (when the lighting switch is in the "AUTO" position).



The two systems work together to operate your lights as shown in the following chart:



**ON: Lights ON**

**LIGHT: When it is light around the light sensor (5).**

**DARK: When it is dark around the light sensor (5).**

Lighting switch position	Main lights to be operated	Ignition mode LOCK (OFF) or ACC		Ignition mode ON	
		LIGHT	DARK	LIGHT	DARK
(1) OFF	Position lights, Tail lights	–	–	–	–
	Headlights	–	–	–	–
(2) AUTO	Position lights, Tail lights	–	–	–	ON
	Headlights	–	–	–	ON
(3) 	Position lights, Tail lights	ON	ON	ON	ON
	Headlights	–	–	–	–
(4) 	Position lights, Tail lights	ON	ON	ON	ON
	Headlights	ON	ON	ON	ON

## BEFORE DRIVING

To turn the lights on or off, twist the knob on the end of the lever. There are four positions:

### OFF (1)

All lights are off.

### AUTO (2)

This function works when it on mode has been changed to ON by pressing the engine switch. The headlights and position lights are turned on and off automatically according to the amount of outside light detected by a sensor. They go out automatically when you change the ignition mode to "ACC" or "LOCK" (OFF) by pressing the engine switch.

The light sensor (5) for sensing the amount of outside light is installed on the upper part of the windshield. It also serves as the rain sensor for the rain-sensing wipers.

### ⚠ CAUTION

If the light sensor area of the windshield is covered with mud, ice, or other similar substances, the headlights and position lights may be turned on even when it is still light outside. Before removing such substances from the windshield, always set the wiper control lever to the "OFF" position. If the lever is left in the "AUTO" position, the wipers could unexpectedly operate and cause injury, and could also be damaged.

### NOTE:

- Avoid covering the light sensor area of the windshield with a sticker. The sticker may impair the performance of the sensor and make the system unable to control operation of the lights correctly.
- If you changed the ignition mode to ON by pressing the engine switch and the "AUTO" position remains selected, the headlights and position lights come on automatically as the outside gets dark even with the engine not running. Leaving the lights lit for a long time may lead to a completely discharged battery.

### ☞ (3)

Front position lights, tail lights, license plate light and instrument lights are on, but headlights are off.

### ☞ (4)

Front position lights, tail lights, license plate light, instrument lights and headlights are on.

### EXAMPLE

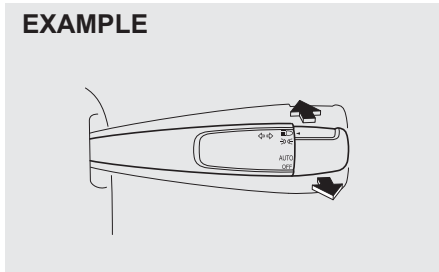

64MS061

With the headlights on, push the lever forward to switch to the high beams (main beams) or pull the lever toward you to switch to the low beams. When the high beams (main beams) are on, a light on the instrument panel will come on. To momentarily activate the high beams (main beams) as a passing signal, pull the lever slightly toward you and release it when you have completed the signal.

### Auto-on headlight system

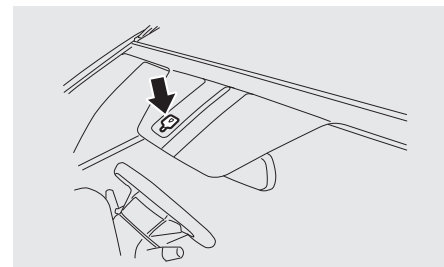

64MS062

The Auto-on headlight system automatically turns on all lights that are operated by the lighting control lever on the steering column, when the following three conditions are all met.

Conditions for Auto-on headlight system operation:

- 1) It is dark around the light sensor (5).
- 2) The lighting control lever is in the "AUTO" position.
- 3) You press the engine switch to change the ignition mode to ON.

This system is operated by a signal from the light sensor (5) on the front windshield. Do not cover the sensor (5). If you do, the system will not work correctly.

### ⚠ WARNING

**It takes about 5 seconds for the light sensor to react to a change in lighting conditions. To help avoid an accident due to reduced visibility, turn on your headlights before driving into a tunnel, parking structure or the like.**

#### NOTE:

*The light sensor is sensitive to infrared rays, so it may operate incorrectly in the region of strong infrared rays.*

### Reprogramming the automatic light function

The following settings of the automatic light function can be customized to your preference. Please contact an authorised Maruti Suzuki workshop if you want the function reprogrammed.

#### Sensitivity of the light sensor

The amount of outside light needed to turn the lights on and off is pre-set at the factory. The sensitivity of the light sensor can be adjusted so that the lights are turned on and off when it is:

- lighter outside than the pre-set condition, or
- darker outside than the pre-set condition

### Rain-triggered automatic lighting operation

The setting of the auto-on headlight system can be changed to make it turn on the headlights:

- when the rain sensor senses heavy rainfall
- when the rain sensor senses light and heavy rainfall (in coordination with rain-sensing wiper operation), or
- independently from rain-sensing wiper operation.

### Light Reminder Buzzer

The interior buzzer continuously beeps if you open the driver's door without turning off the headlights and position lights. This function is triggered under the following condition:

The headlights and/or position lights are on even after the ignition switch is turned off, or the engine switch is pressed to change the ignition mode to LOCK (OFF).

The buzzer stops sounding when you turn off the headlights and position lights.

#### NOTE:

*A message is indicated on the information display in the instrument cluster while the buzzer is sounding.*

### Front Fog Light Switch (if equipped)

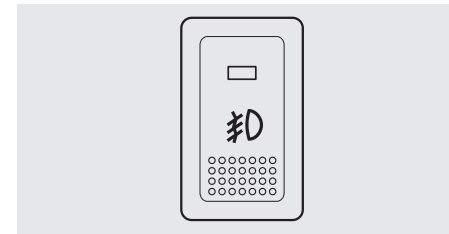

64J058

The front fog light comes on when the fog light switch is pushed in with the position lights, tail lights and/or the headlights are on. An indicator light above the switch will be lit when the front fog light is on.

#### NOTE:

*In some countries the lighting operation may be different from the above description according to local regulations.*

## BEFORE DRIVING

### Headlight Leveling Switch

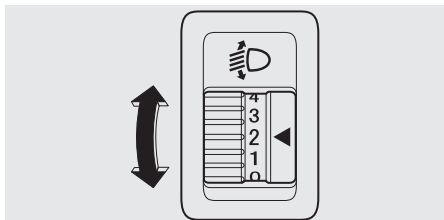

80JM040

Level the headlight beam according to the load condition of your vehicle by turning this switch. The chart below shows the appropriate switch position for different vehicle-load conditions.

Vehicle Load Condition	Switch Position	
	D13A Engine	D16AA Engine
Driver only	0	0
Driver + 1 passenger (in front seat)	0	0
Driver + 4 passengers, no cargo	1	1
Driver + 4 passengers, cargo added	2	2
Driver + full cargo	3	3

### Turn Signal Control Lever

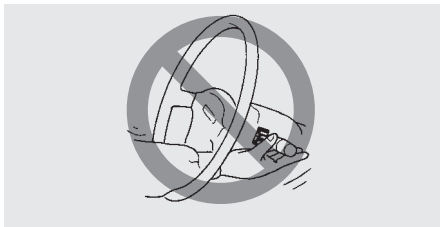

65D611

#### **⚠ WARNING**

**To avoid possible injury, do not operate controls by reaching through the steering wheel.**

### Turn Signal Operation

With the ignition switch in the “ON” position or the ignition mode ON, move the lever up or down to activate the right or left turn signals.

#### Normal turn signal

##### EXAMPLE

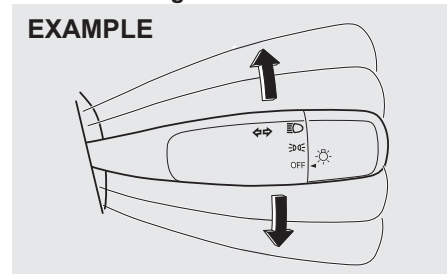

60MK013

Move the lever all the way upward or downward to signal. When the turn is completed, the signal will cancel and the lever will return to its normal position.

#### Lane change signal

##### EXAMPLE

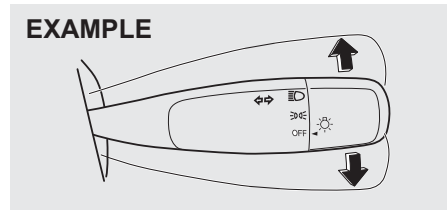

60MK014

Move the lever part-way in the direction to turn and hold it there.

- The turn signal and its indicator flash while the lever is held at the moved position.

The turn signal and its indicator flash three times even if you return the lever immediately after moving it.

**NOTE:**

*The turn signal and its indicator can be set whether they flash three times after the turn signal lever is returned via the information display. Refer to "Information Display" in this section.*

**NOTE:**

*You can customize the setting for the number of times of flashing of the turn signal and its indicator (1 to 4 times). Please ask an authorised Maruti Suzuki workshop for the customization.*

### Hazard Warning Switch

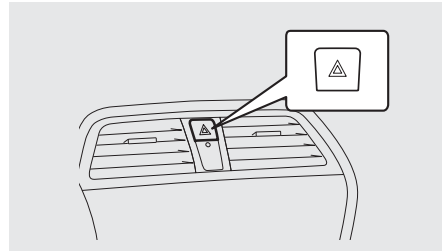

61M0163

Push in the hazard warning switch to activate the hazard warning lights. All turn signal lights and both turn signal indicators will flash simultaneously. To turn off the lights, push the switch again. Use the hazard warning lights to warn other traffic during emergency parking or when your vehicle could otherwise become a traffic hazard.

### Windshield Wiper and Washer Lever

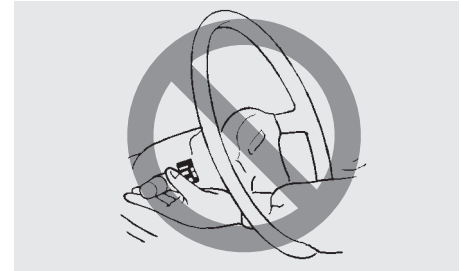

57L21128

**⚠ WARNING**

**To avoid possible injury, do not operate controls by reaching through the steering wheel.**

## BEFORE DRIVING

### Wiper and Washer Operation

When the ignition switch is in the “ON” position or the ignition mode is ON, you can use the wiper/washer lever or switch (if equipped).

### Windshield Wipers

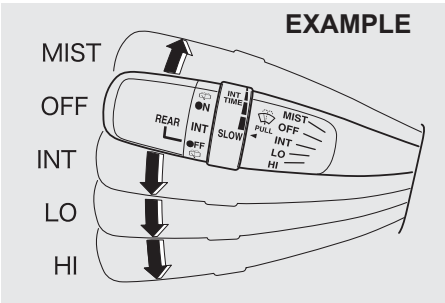

To turn the windshield wipers on, move the lever down to one of the three operating positions. In the “INT” position, the wipers operate intermittently. The “INT” position is very convenient for driving in mist or light rain. In the “LO” position, the wipers operate at a steady low speed. In the “HI” position, the wipers operate at a steady high speed. To turn off the wipers, move the lever back to the “OFF” position.

Move the lever up and hold it to the “MIST” position, the windshield wipers will turn on continuously at low speed.

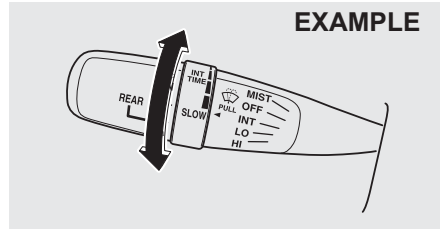

If the lever is equipped with the “INT TIME” control, turn the control forward or rearward to adjust the intermittent wiper operation to the desired interval.

### Windshield Wipers with Rain Sensing Function (if equipped)

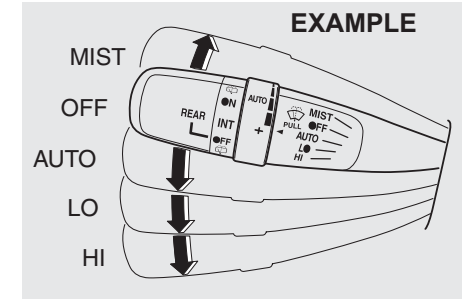

Press the engine switch to change the ignition mode to ON. To turn the rain-sensing wipers on, move the lever down to one of the three operating positions. In the “AUTO” position (if provided), the wipers automatically operate when the wiper system senses rain or snow. In the “LO” position, the wipers operate at a steady low speed. In the “HI” position, the wipers operate at a steady high speed. To turn off the wipers, move the lever back to the “OFF” position.

Move the lever up and hold it to the “MIST” position; the wipers will operate continuously at low speed for as long as you hold the lever in the “MIST” position.

## EXAMPLE

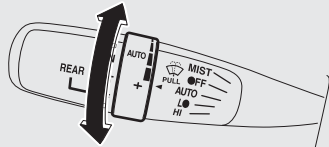

64MS066

If the control lever has on “AUTO” position, you can change the system’s sensitivity to rain/snow by turning the knob of the control lever forward for increased sensitivity or rearward for decreased sensitivity.

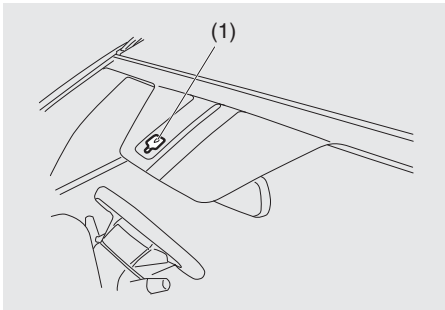

61M0219

(1) Rain sensor

## CAUTION

- **Observe the following instructions when the wiper lever is set to the “AUTO” position with the engine switch in the ON mode. Otherwise, the wipers could unexpectedly operate and cause injury, and could also be damaged.**
  - Do not touch or wipe the rain sensor area of the windshield with a cloth.
  - Do not hit the windshield or rain sensor.
- **Be sure to set the wiper control lever to the “OFF” position before washing the vehicle in an automatic car wash or cleaning the windshield.**

## NOTE:

- *Under the following conditions, the rain sensor may not be able to sense rain or snow correctly, and thus the rain-sensing wiper function may not work or may work incorrectly. (Use a position other than “AUTO” under these conditions.)*
  - Rain or snow does not hit the rain sensor area of the windshield, or the snow is not of a type that is able to be detected by the sensor.
  - The rain sensor area is covered with mud, ice or other similar substance. You should remove any foreign substance.

- *There were already raindrops on the windshield before starting rain-sensing wiper operation. You should remove the raindrops by operating the wipers under manual control.*
- *The rain sensor is hotter than 80°C (176°F) in the sun or lower than –10°C (14°F) in freezing weather. (The wipers do not operate under this condition.)*
- *The windshield is coated with a water-repellent substance, which causes raindrops to run down quickly. This will give a clearer view and the wipers may seem to operate too frequently. In this case, decrease the system’s sensitivity.*
- *The sensor area is covered with a sticker.*
- *The wiper blades are damaged. You should replace them.*
- *The following conditions may indicate problems with the rain-sensing wiper system. If your system exhibits any of the following conditions, have it inspected by an authorised Maruti Suzuki workshop.*
  - *Rainfall/snowfall rate varies but the wiping interval remains constant.*
  - *Rain/snow is falling but the wipers do not operate.*

## BEFORE DRIVING

### Reprogramming the rain-sensing wiper function

The "AUTO" position operation of the rain-sensing wiper function can be customized to your preference by reprogramming its setting as follows. Please contact an authorised Maruti Suzuki workshop for this customization.

### Full-automatic wiping (factory setting)

The system automatically selects the most appropriate of the following wiping modes: no wiping, intermittent wiping, low-speed wiping, and high-speed wiping.

### Semi-automatic wiping

The system automatically selects the most appropriate of the following wiping modes: intermittent wiping, low-speed wiping, or high-speed wiping. (The wipers do not stop automatically.)

### Intermittent wiping

The wipers operate only in the intermittent wiping mode. The wiping interval can be changed with the knob on the control lever.

### Windshield Washer

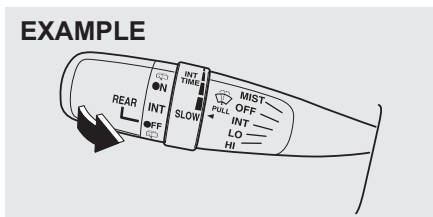

64MS067

To spray windshield washer fluid, pull the lever toward you. The windshield wipers will automatically turn on at low speed if they are not already on and the "INT" position is equipped.

### **! WARNING**

- To prevent windshield icing in cold weather, turn on the defroster to heat the windshield before and during windshield washer use.
- Do not use radiator antifreeze in the windshield washer reservoir. It can severely impair visibility when sprayed on the windshield, and can also damage your vehicle's paint.

### **NOTICE**

To help prevent damage to the windshield wiper and washer system components, you should take the following precautions:

- Do not continue to hold in the lever when there is no windshield washer fluid being sprayed or the washer motor can be damaged.
- Do not attempt to remove dirt from a dry windshield with the wipers or you can damage the windshield and the wiper blades. Always wet the windshield with washer fluid before operating the wipers.
- Clear ice or packed snow from the wiper blades before using the wipers.
- Check the washer fluid level regularly. Check it often when the weather is bad.
- Only fill the washer fluid reservoir 3/4 full during cold weather to allow room for expansion if the temperature falls low enough to freeze the solution.



### Rear Window Wiper/Washer Switch (if equipped)

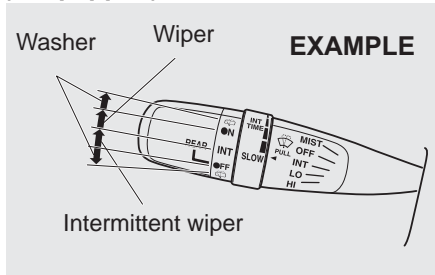

64MS068

To turn the rear wiper on, twist the rear wiper switch on the end of the lever forward to the "ON" position. If your vehicle is equipped the "INT" position, the rear wiper operates intermittently when you twist the switch forward to the "INT" position. To turn the rear wiper off, twist the switch rearward to the "OFF" position.

With the rear wiper in the "OFF" position, twist the switch rearward and hold it there to spray window washer fluid.

With the rear wiper in the "ON" position, turn the switch forward and hold it there to spray window washer fluid.

### NOTICE

Clear ice or snow from the rear window and rear wiper blade before using the rear wiper. Accumulated ice or snow could prevent the wiper blade from moving, causing damage to the wiper motor.

### Tilt/Telescoping (if equipped) Steering Lock Lever

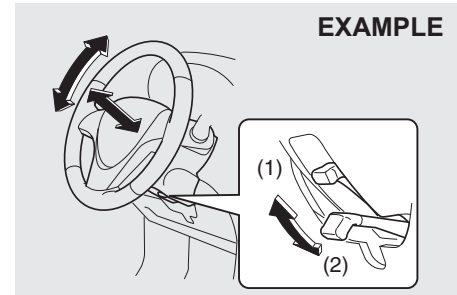

61MM0A085

- (1) LOCK
- (2) UNLOCK

The lock lever is located under the steering column. To adjust the steering wheel height and fore-aft position:

- 1) Push down the lock lever to unlock the steering column.
- 2) Adjust the steering wheel to the desired height and fore-aft position and lock the steering column by pulling up the lock lever.
- 3) Try moving the steering wheel up and down and back and forth to make sure it is securely locked in position.

### ⚠ WARNING

Never attempt to adjust the steering wheel while the vehicle is moving or you could lose control of the vehicle.

## BEFORE DRIVING

### Horn

#### EXAMPLE

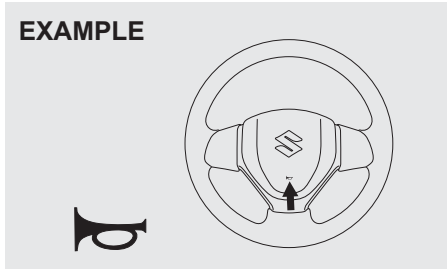

68LM240

Press the horn button of the steering wheel to sound the horn. The horn will sound with the ignition switch in any position or any ignition mode.

### Heated Rear Window Switch (if equipped)

#### Type 1

#### EXAMPLE

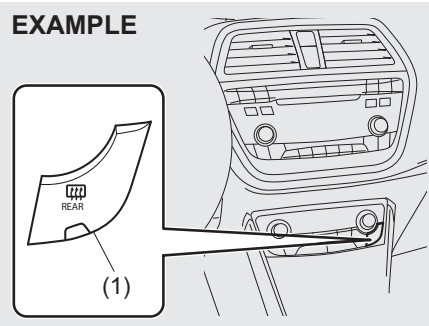

64MS167

#### Type 2

#### EXAMPLE

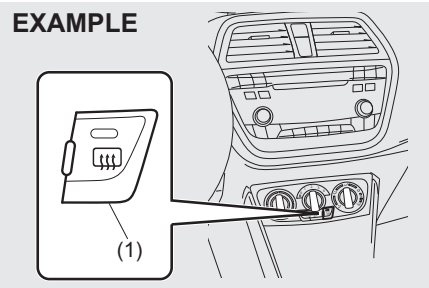

64MS168

When the rear window is misted, push this switch (1) to clear the mist from the window.

An indicator light will be lit when the defogger is on. The defogger will work only when the engine is running. To turn off the defogger, push the switch (1) again.

#### NOTICE

**The heated rear window uses a large amount of electricity. Be sure to turn off after the window and mirrors have become clear.**

#### NOTE:

- The defogger will work only when the engine is running.
- The defogger will automatically turn off after the defogger remains on for 15 minutes to prevent discharging of the battery.

## OPERATING YOUR VEHICLE

Exhaust Gas Warning .....	3-1
Daily Inspection Checklist .....	3-1
Engine Oil Consumption .....	3-2
Ignition Switch (Vehicle without Keyless Push Start System) .....	3-3
Engine Switch (Vehicle with Keyless Push Start System) .....	3-5
Keyless Push Start System (if equipped) .....	3-6
Parking Brake Lever .....	3-9
Pedal .....	3-10
Starting the Engine (Vehicle without Keyless Push Start System) .....	3-11
Starting the Engine (Vehicle with Keyless Push Start System) .....	3-12
Using the Transaxle .....	3-14
Cruise Control (if equipped) .....	3-16
Parking Sensors (if equipped) .....	3-18
Rearview Camera (if equipped) .....	3-24
Braking .....	3-27

## OPERATING YOUR VEHICLE

### Exhaust Gas Warning

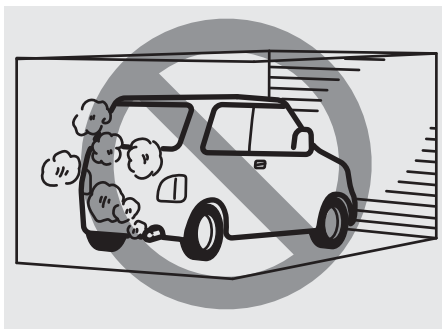

52D334

#### ⚠ WARNING

Avoid breathing exhaust gases. Exhaust gases contain carbon monoxide, a potentially lethal gas that is colorless and odorless. Since carbon monoxide is difficult to detect by itself, be sure to take the following precautions to help prevent carbon monoxide from entering your vehicle.

- Do not leave the engine running in garages or other confined areas.
- Do not park with the engine running for a long period of time, even in an open area. If it is necessary to sit for a short time in a parked vehicle with the engine running, make sure the air intake selector is set to the fresh air position and the blower is at high speed.

(Continued)

#### ⚠ WARNING

(Continued)

- Avoid operating the vehicle with the tailgate or trunk open. If it is necessary to operate the vehicle
- with the tailgate or trunk open, make sure the sunroof (if equipped) and all windows are closed, and the blower is at high speed with the air intake selector set to the fresh air position.
- To allow proper operation of your vehicle's ventilation system, keep the air inlet grille in front of the windshield clear of snow, leaves or other obstructions at all times.
- Keep the exhaust tailpipe area clear of snow and other material to help reduce the buildup of exhaust gases under the vehicle. This is particularly important when parked in blizzard conditions.
- Have the exhaust system inspected periodically for damage and leaks. Any damage or leaks should be repaired immediately.

### Daily Inspection Checklist

#### Before Driving



60A187

- 1) Make sure that windows, mirrors, lights and reflectors are clean and unobstructed.
- 2) Visually check the tires for the following points:
  - the depth of the tread groove
  - abnormal wear, cracks and damage
  - loose wheel nuts
  - existence of foreign material such as nails, stones, etc.

Refer to "Tires" in "**INSPECTION AND MAINTENANCE**" section for details.

- 3) Look for fluid and oil leaks.

#### NOTE:

*It is normal for water to drip from the air conditioning system after use.*

- 4) Make sure the hood is fully closed and latched.
- 5) Check the headlights, turn signal lights, brake lights and horn for proper operation.
- 6) Adjust the seat and head restraint.
- 7) Check the brake pedal and the parking brake lever.
- 8) Adjust the mirrors.
- 9) Make sure that you and all passengers have properly fastened the seat belts.
- 10) Make sure that all warning lights come on as the ignition switch is turned to the "ON" position or the engine switch is pressed to change the ignition mode to ON.
- 11) Check all gauges.
- 12) Make sure that the BRAKE SYSTEM WARNING light turns off when the parking brake is released.

Once a week, or each time you fill your fuel tank, perform the following under-hood checks:

- 1) Engine oil level
- 2) Coolant level
- 3) Brake fluid level
- 4) Battery electrolyte level
- 5) Windshield washer fluid level
- 6) Hood latch operation  
Pull the hood release handle inside the vehicle. Make sure that you cannot open the hood all the way without releasing the secondary latch. Be sure to close the hood securely after checking for proper latch operation. See the

item "All latches, hinges and locks" of "CHASSIS AND BODY" in the "Periodic Maintenance Schedule" in the "INSPECTION AND MAINTENANCE" section for lubrication schedule.

**⚠ WARNING**

**Make sure the hood is fully closed and latched before driving. If it is not, it can fly up unexpectedly during driving, obstructing your view and resulting in an accident.**

Once a month, or each time you fill your fuel tank, check the tire pressure using a tire pressure gauge. Also check the tire pressure of the spare tire.

## Engine Oil Consumption

It is normal for the engine to consume some engine oil during normal vehicle operation.

The amount of engine oil consumed depends on the viscosity of the oil, the quality of the oil and the conditions under which the vehicle is driven.

More oil is consumed during high-speed driving and when there is frequent acceleration and deceleration. Under high loads, your engine also will consume more oil.

A new engine also consumes more oil, since its pistons, piston rings and cylinder walls have not yet become conditioned. New engines reach the normal level of oil consumption only after approximately 5000 km (3000 miles) driving.

**Oil consumption:  
Max. 1.0 L per 1000 km  
(1 Qt. per 600 miles)**

When judging the amount of oil consumption, note that the oil may become diluted and make it difficult to accurately judge the true oil level.

As an example, if a vehicle is used for repeated short trips, and consumes a normal amount of oil, the dipstick may not show any drop in the oil level at all, even after 1000 km (600 miles) or more of driving. This is because the oil is gradually becoming diluted with fuel or moisture,

## OPERATING YOUR VEHICLE

making it appear that the oil level has not changed.

You should also be aware that the diluting ingredients evaporate out when the vehicle is subsequently driven at high speeds, such as on an expressway, making it appear that oil is excessively consumed after high-speed driving.

### Ignition Switch (Vehicle without Keyless Push Start System)

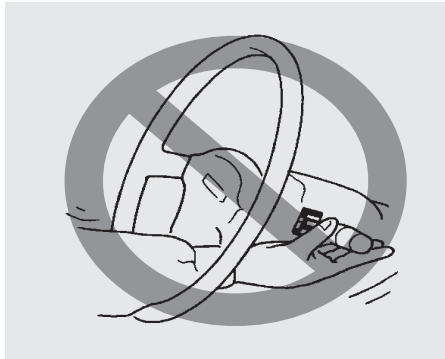

65D611

#### **WARNING**

To avoid possible injury, do not operate controls by reaching through the steering wheel.

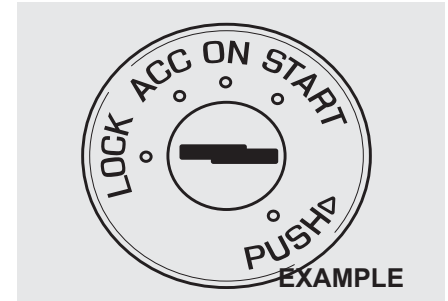

52KM052

The ignition switch has the following four positions:

#### **LOCK**

This is the normal parking position. It is the only position in which the key can be removed.

#### **EXAMPLE**

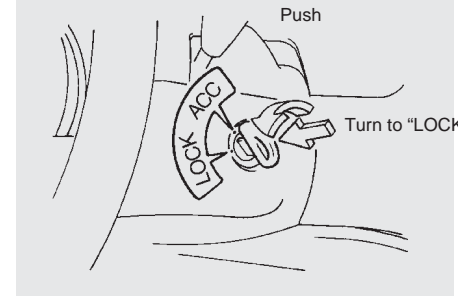

60G033

You must push in the key to turn it to the "LOCK" position. It locks the ignition, and prevents normal use of the steering wheel after the key is removed.

To release the steering lock, insert the key and turn it clockwise to one of the other positions. If you have trouble turning the key to unlock the steering, try turning the steering wheel slightly to the right or left while turning the key.

### ACC

Accessories such as the radio can operate, but the engine is off.

### ON

This is the normal operating position. All electrical systems are on.

### START

This is the position for starting the engine using the starter motor. The key should be released from this position as soon as the engine starts.

### Ignition key reminder (if equipped)

A buzzer sounds intermittently to remind you to remove the ignition key if it is in the ignition switch when the driver's door is opened.



81A297S

### NOTICE

- Do not use the starter motor for more than 30 seconds at a time. If the engine does not start, wait 15 seconds before trying again. If the engine does not start after several attempts, check the fuel and ignition systems or consult your authorised Maruti Suzuki workshop.
- Do not leave the ignition switch in the "ON" position if the engine is not running as the battery will discharge.

### ⚠ WARNING

- Never return the ignition switch to the "LOCK" position and remove the ignition key while the vehicle is moving. The steering wheel will lock and you will not be able to steer the vehicle.
- Always return the ignition switch to the "LOCK" position and remove the ignition key when leaving the vehicle even if only for a short time. Also do not leave children alone in a parked vehicle. Unattended children could cause accidental movement of the vehicle or could tamper with power windows or power sunroof (if equipped). They also could suffer from heat stroke in warm or hot weather. These could result in severe injury or even death.

### Engine Switch (Vehicle with Keyless Push Start System)

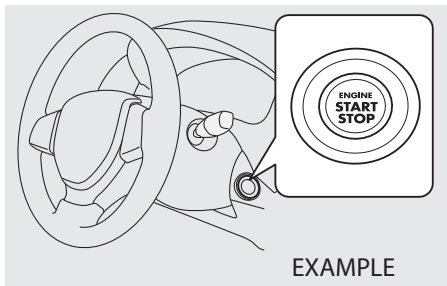

61MM0B001

#### LOCK (OFF)

Once this mode is selected by pressing the engine switch, opening or closing of any door (including the tailgate) will result in automatic locking or steering.

#### ACC

Press the engine switch to select this ignition mode to use such electric equipment as the audio system, outside rearview mirrors and accessory socket with the engine off. When this position is selected, the information display in the instrument cluster shows the following message: "ACC" IGNITION SWITCH POSITION. Refer to "Information Display" in the "BEFORE DRIVING" section for details.

#### • With the engine off

You can use such electric equipment as the power windows and wipers with the engine off. When this ignition mode is selected by pressing the engine switch, the information display in the instrument cluster shows the following message: "ON" IGNITION SWITCH POSITION.

#### • With the engine on

All electric equipment is operational. The vehicle can be driven when you have selected this ignition mode by pressing the engine switch.

#### START

If you have the keyless push start system controller with you, you can start the engine after shifting to "N" (neutral),

depressing the brake and clutch pedal and pressing the engine switch to select the ignition mode.

#### NOTE:

*You do not need to keep the engine switch pressed to start the engine.*

#### NOTICE

**Do not leave the engine switch in the "ACC" or "ON" mode when the engine is not running. Avoid using the radio or other electric accessories for a long time when the engine switch is in the "ACC" or "ON" mode when the engine is not running, otherwise the battery may discharge.**



**NOTE:**

*In the presence of strong radio signals or noise, you may not be able to change the ignition mode to ACC or ON or to start the engine using the engine switch. In this case, the information display on the instrument cluster will show the following message: KEY FOB NOT DETECTED.*

**Unreleased Steering Lock Warning**

If the steering lock remains engaged when you press the engine switch to change the ignition mode to "ON", the information display in the instrument cluster shows the message: "TRN. STEERING WHEEL TO RELEASE LOCK". Refer to "Information Display" in the "**BEFORE DRIVING**" section for details.

**NOTE:**

*The steering lock may not be released if some load is acting on the steering wheel. If this happens, turn the steering wheel to the right or left to relieve it from the load before you press the engine switch again to change to the desired ignition mode.*

**Keyless Push Start System (if equipped)**

Provided the keyless push start system remote controller is within the "interior workable area" (refer to the related explanation in this section), you can use the engine switch for starting the engine and selecting an ignition mode (ACC or ON). In addition, the following functions can be used:

- Keyless entry function. Refer to "Keyless Push Start System Remote Controller" in the "BEFORE DRIVING" section for details.
- Locking and unlocking doors (including the tailgate) using a request switch. Refer to "Keyless Push Start System Remote Controller" in the "BEFORE DRIVING" section for details.
- Immobilizer (anti-theft) function. Refer to "Immobilizer System" in the "BEFORE DRIVING" section for details.

**Engine Switch Illumination**

The engine switch is illuminated (lit) in the following situations:

- When the engine is off and the driver's door is open or for 15 seconds after the driver's door is closed.
- When the engine is off and the position lights are on. The illumination will go out when the position lights are turned off.
- When the engine is on and the position lights and/or the headlights are on. The

illumination will go out when the headlights are turned off.

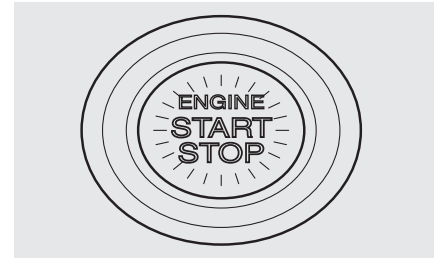

82K253

**NOTE:**

*To save the battery, the illumination will be automatically turned off when both of the following conditions are simultaneously met:*

- *The headlights and position lights are turned off.*
- *A period of 15 minutes has elapsed after opening the driver's door.*

**Selection of Ignition Modes**

Press the engine switch to select the "ACC" or "ON" mode as follows when you use an electric accessory or check the operation of instruments without running the engine.

- 1) Bring the keyless push start system remote controller with you and sit in the driver's seat.

## OPERATING YOUR VEHICLE

- Without depressing the clutch pedal, press the engine switch (1).

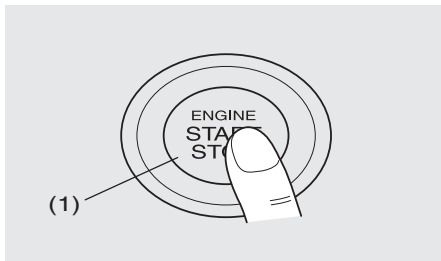

82K254

Every time you press the engine switch, the ignition mode changes as follows.

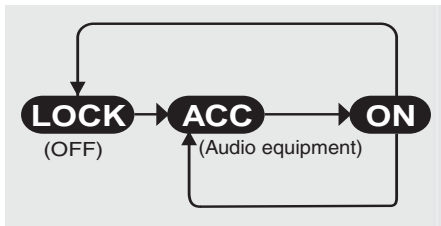

57L31033

### NOTE:

When selecting the ignition modes, the information display in the instrument cluster shows certain messages. Refer to "Information Display" in the "BEFORE DRIVING" section for details.

### If the MASTER WARNING indicator light blinks and the ignition modes cannot be selected

Your keyless push start system remote controller may not be sensed as being within the "interior workable area" (refer to the related explanation in this section). Try again after making sure you have the remote controller with you. If the ignition modes still cannot be selected, the battery of the remote controller may be discharged. To be able to select an ignition mode, you must then use the following method:

### EXAMPLE

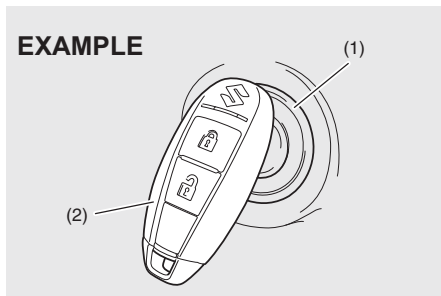

58MST0302

- Without depressing the brake pedal and the clutch pedal, push the engine switch (1).
- Within about 10 seconds during which the master warning indicator light in the instrument cluster is blinking and the "PLACE KEY FOB ON START SWITCH" message appears on the information display, touch the engine

switch with the lock button end of the remote controller (2) for about 2 seconds.

### NOTE:

- If you still cannot select the ignition modes, there may be some problem with the keyless push start system. Contact an authorised Maruti Suzuki workshop for an inspection of the system.
- The immobilizer/keyless push start system warning light will come on for about 5 seconds while the master warning indicator light is blinking. In addition, the information display in the instrument cluster will show a message during this time. Refer to "Information Display" in the "BEFORE DRIVING" section for details.
- You may customize the system to cause the interior buzzer to sound once for the remote controller out of sensing range warning. To incorporate this customization, please contact an authorised Maruti Suzuki workshop.
- If the battery of the remote controller is about to become completely discharged, the corresponding message will appear on the information display when you press the engine switch to change the ignition mode to ON. Refer to "Information Display" in the "BEFORE DRIVING" section for details. For details on replacing the battery, refer to the "Keyless Push Start System Remote Controller" in the "BEFORE DRIVING" section.

### Remote Controller Outside Warning

When either of the conditions described below is met, the system issues the remote controller outside warning by sounding the interior and exterior buzzers. At the same time, the immobilizer/keyless push start system warning light comes on and the master warning indicator light blinks.

- Any door is opened and then closed while the remote controller is not inside the vehicle and the engine is running or the ignition mode has been changed to “ACC” or “ON” by pressing the engine switch.
- The remote controller is not inside the vehicle when you attempt to start the engine after changing the ignition mode to “ACC” or “ON” by pressing the engine switch.

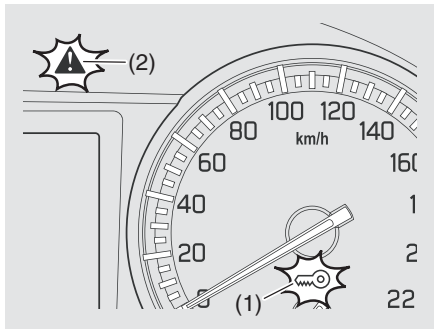

61MM0A182

- (1) Immobilizer/keyless push start system warning light (blinks)
- (2) Master warning indicator light (blinks)

**NOTE:**

- If the warning is given, locate the remote controller as soon as possible.
- Any attempt to start the engine will fail while the warning is active. The message appearing on the information display in the instrument cluster will also indicate this condition. Refer to “Information display” in the “BEFORE DRIVING” section for details.
- Normally, the immobilizer/keyless push start system warning light should go out and the master warning indicator light should stop blinking shortly after the remote controller is brought back inside the vehicle. If they remain lit and blinking, change the ignition mode to “LOCK” (OFF) by pressing the engine switch and then perform the engine starting operation. Refer to “Starting the Engine” in this section.
- Always keep the remote controller with you as the driver.

### Interior Workable Area for Engine Starting, Ignition Mode Selection and Remote Controller Outside Warning

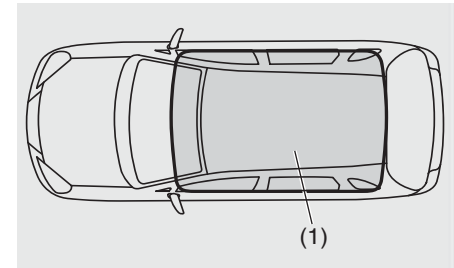

61MM0B002

(1) Interior workable area

The interior workable area for these functions is defined as all the interior spaces except for the space above the instrument panel.

**NOTE:**

- Even when the remote controller is in the “interior workable area”, if it is in any of the following conditions, you may not be able to start the engine or select the ignition modes, and the remote controller outside warning may be given.
  - The remote controller’s battery is low.
  - The remote controller is affected by strong radio signals or noise.
  - The remote controller is in contact with or covered by a metallic object.

## OPERATING YOUR VEHICLE

- The remote controller is in stowage like the glove box or a door pocket.
- The remote controller is in the sun visor pocket or on the floor.
- Even when the remote controller is outside the “interior workable” area, if it is in any of the following conditions, you may be able to start the engine or select the ignition mode. The “remote controller outside” warning may not be given at that time.
  - The remote controller is outside the vehicle but very close to a door.
  - The remote controller is on the instrument panel.

### Parking Brake Lever

#### EXAMPLE

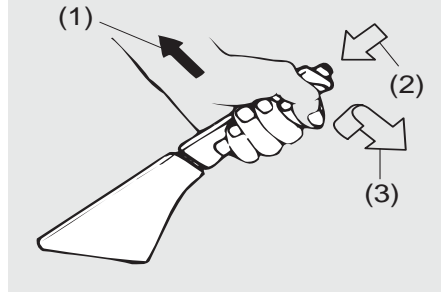

64MS185

- (1) To set
- (2) To release
- (3) To release

The parking brake lever is located between the seats. To set the parking brake, hold the brake pedal down and pull the parking brake lever all the way up. To release the parking brake, hold the brake pedal down, pull up slightly on the parking brake lever, push the button on the end of the lever with your thumb, and lower the lever to its original position.

#### ⚠ WARNING

- Never drive your vehicle with the parking brake on: rear brake effectiveness can be reduced from overheating, brake life may be shortened, or permanent brake damage may result.
- If the parking brake does not hold the vehicle securely or does not fully release, have your vehicle inspected immediately by an authorised Maruti Suzuki workshop.

#### ⚠ WARNING

Always set the parking brake fully before leaving your vehicle or it may move, causing injury or damage. When parking, make sure the gearshift lever is in reverse or first gear. Remember, even though the transaxle is in gear, you must set the parking brake fully.

#### ⚠ WARNING

When parking the vehicle in extremely cold weather, the following procedure should be used:

- 1) Set the parking brake.
- 2) Turn off the engine, then shift into reverse or first gear.
- 3) Get out of the vehicle and put chocks under the wheels. Release the parking brake.

When you return to your vehicle, you must remember to first set the parking brake, then remove the wheel chocks.

### Parking Brake Reminder Buzzer

A buzzer sounds intermittently to remind you to release the parking brake if you start the vehicle without releasing the parking brake. Make sure that the parking brake is fully released and the brake system warning light turns off.

### Pedal

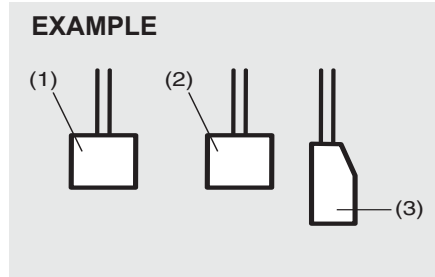

80J2121

#### Clutch Pedal (1)

The clutch pedal is used to disengage the drive to the wheels when starting the engine, stopping, or shifting the gearshift lever. Depressing the pedal disengages the clutch.

#### **⚠ WARNING**

**Do not drive with your foot resting on the clutch pedal. It could result in excessive clutch wear, clutch damage, or unexpected loss of engine braking.**

#### Brake Pedal (2)

Your vehicle is equipped with either front and rear disc brakes or front disc brakes and rear drum brakes. Depressing the brake pedal applies both sets of brakes.

You may hear occasional brake squeal when you apply the brakes. This is a nor-

mal condition caused by environmental factors such as cold, wet, snow, etc.

#### **⚠ WARNING**

**If brake squeal is excessive and occurs each time the brakes are applied, you should have the brakes checked by your authorised Maruti Suzuki workshop.**

#### **⚠ WARNING**

**Do not ride the brakes by applying them continuously or resting your foot on the pedal. This will result in overheating of the brakes which could cause unpredictable braking action, longer stopping distances, or permanent brake damage.**

#### Accelerator Pedal (3)

This pedal controls the speed of the engine. Depressing the accelerator pedal increases power output and speed.

## OPERATING YOUR VEHICLE

### Starting the Engine (Vehicle without Keyless Push Start System)

#### Before Starting the Engine

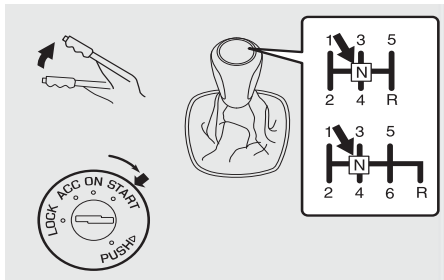

64MS146

- 1) Make sure the parking brake is set fully.
- 2) Shift into "N" (Neutral) and depress the clutch pedal all the way to the floor. Hold the clutch pedal while starting the engine.

#### **WARNING**

- Make sure that the parking brake is set fully and the transaxle is in Neutral before attempting to start the engine.
- Engine can be started only after depressing the clutch pedal. However, before depressing the clutch pedal make sure that the transaxle is in Neutral and brake pedal is depressed.

### Starting a Cold and Warm Engine

#### Cold engine

Turn the ignition switch to the "ON" position and wait until the glow plug indicator goes out if it comes on. Crank the engine by turning the ignition key to "START". Release the key when the engine starts.

#### **NOTICE**

- Stop turning the starter immediately after the engine has started or the starter system can be damaged.
- Do not crank the engine for more than 30 seconds at a time. If the engine doesn't start on the first try, wait about 15 seconds before trying again.

#### Warm engine

Crank the engine by turning the ignition key to "START". Release the key when the engine starts.

#### Caution when stopping the engine with turbocharger

When stopping the engine after climbing or high speed driving, let the engine idle for about one minute or more (if it is not prohibited) to cool down the turbocharger and engine oil. This is to prevent the engine oil from over-deteriorating. Deteriorated engine oil will damage the bearings of the turbocharger.

#### Restarting diesel engine after fuel-empty stop

If the engine stops and the low fuel warning light and the malfunction indicator light come on, use the following procedure:

- 1) Fill the fuel tank.
- 2) Hold the ignition key in "ON" position for 5-10 seconds to feed fuel.
- 3) Perform above engine starting procedure to start the engine.

If the malfunction indicator light still comes on after the engine started, there may be some problem with the engine. Ask your authorised Maruti Suzuki workshop to have the engine inspected.

## Starting the Engine (Vehicle with Keyless Push Start System)

### Before Starting the Engine

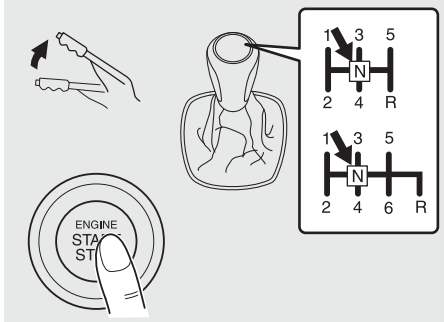

64MS169

- 1) Make sure the parking brake is set fully.
- 2) Shift to "N" (Neutral) and fully depress the clutch pedal. Hold the clutch and brake pedals fully depressed.

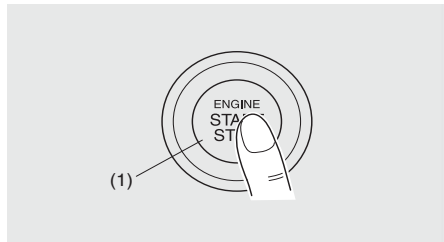

82K254

- 3) The "PUSH START SWITCH" message will appear on the information display in the instrument cluster. Push the engine switch (1). When the engine is started, the starter motor will automatically stop.

### ⚠ WARNING

**Make sure that the parking brake is set fully and the transaxle is in Neutral before attempting to start the engine.**

### NOTICE

- Do not depress the accelerator during the engine starting procedure.
- If the engine does not respond when you try to start it with the engine switch or if the engine switch continuous to cycle through the "LOCK" (OFF) - "ACC" - "ON" mode, the vehicle battery may be discharged. Check the voltage of the vehicle battery before trying again.

### NOTE:

- You do not need to keep the engine switch pressed to start the engine.
- The engine of a manual transaxle vehicle will not start unless the clutch pedal is depressed.
- During the engine starting procedure, messages on the information display will help you. Refer to "Information Display"

in the "BEFORE DRIVING" section for details.

- You should turn off such loads as the headlights and air conditioning system to facilitate starting of the engine.
- Even if you fail to start the engine, the starter motor will stop operating automatically after a short time. After the starter motor has stopped or if there is some problem with the system, the starter motor will rotate only while the engine switch is being pressed.

### Stopping the engine

- Depress the engine switch to stop the engine after the vehicle stopped completely.
- In case of emergency, you can stop the engine by quickly pushing the engine switch more than 3 times, or pushing and holding the engine switch more than 2 seconds while the vehicle in motion.

### NOTE:

Except in emergency, do not stop the engine while the vehicle in motion.

The steering and braking operation will require more efforts when the engine stopped.

Refer to "Braking" in this section.

- If the engine has been stopped and stayed as it as for while after the engine was stopped unexpectedly or was raced before stopped, a clicking sound may be heard from around the engine when engine restarted. This is not a malfunction.

## OPERATING YOUR VEHICLE

tion. In this case, always let the engine idle before stop it.

### Starting a Cold and Warm Engine

#### Cold engine

Depress the clutch and brake pedals fully and press the engine switch to crank the engine. If the glow plug indicator light comes on, the engine will start automatically after the glow plug indicator light goes off or 10 seconds past.

#### NOTICE

**Do not crank the engine for more than 30 seconds at a time.**

**If the engine doesn't start on the first try, wait about 15 seconds before trying again.**

#### Warm engine

Crank the engine by pressing the engine switch to change the ignition mode to "START".

### Caution when stopping the engine with turbocharger

When stopping the engine after climbing or high speed driving, let the engine idle for about one minute or more (if it is not prohibited) to cool down the turbocharger and engine oil. This is to prevent the engine oil from over-deteriorating. Deteriorated engine oil will damage the bearings of the turbocharger.

### Restarting diesel engine after fuel-empty stop

If the engine stops and the low fuel warning light and the malfunction indicator light come on, use the following procedure:

- 1) Fill the fuel tank.
- 2) Press the engine switch to change the ignition mode to "ON" for 5-10 seconds to feed fuel.
- 3) Perform above engine starting procedure to start the engine.

If the malfunction indicator light still comes on after the engine started, there may be some problem with the engine. Ask your authorised Maruti Suzuki workshop to have the engine inspected.

### If the MASTER WARNING indicator light blinks and the engine cannot be started

Your keyless push start system remote controller may not be sensed as being within the interior workable area. Try again after making sure that you have the remote controller with you. If the engine still cannot be started, the battery of the remote controller may be discharged. You must

then use the following method to be able to start the engine.

### EXAMPLE

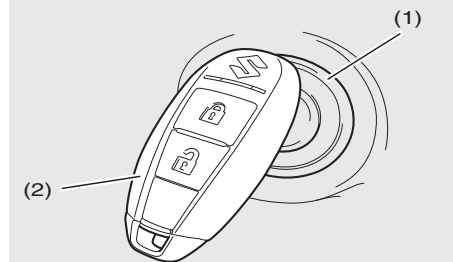

58MST0302

- 1) Make sure the parking brake is set fully.
- 2) Shift to "N" (Neutral) and fully depress the clutch pedal. Hold the clutch and brake pedals fully depressed.
- 3) The "PUSH START SWITCH." message will appear on the information display in the instrument cluster. Press the engine switch (1).
- 4) Within about 10 seconds of blinking of the "MASTER WARNING" indicator light in the instrument cluster, touch the engine switch with the lock button end of the remote controller (2) for about 2 seconds.

#### NOTE:

- If you still cannot start the engine after several attempts using the above



method, there may be a problem elsewhere, such as a low battery. Contact your authorised Maruti Suzuki workshop for inspection.

- The immobilizer/keyless push start system warning light will come on for about 5 seconds while the master warning indicator light is blinking. In addition, the information display will show a certain message during this time. Refer to "Information Display" in the "BEFORE DRIVING" section for details.
- You may customize the system to cause the interior buzzer to sound once for the remote controller out of sensing range warning. Please contact an authorised Maruti Suzuki workshop for the customization.
- If the battery of the remote controller is about to be completely discharged, a message warning this will appear on the information display when the ignition mode is changed to "ON" by pressing the engine switch. For details on replacing the battery, refer to the "Keyless Push Start System Remote Controller" in the "BEFORE DRIVING" section.

### Returning the ignition mode to "LOCK" (OFF)

#### "LOCK" (OFF) mode reminder buzzer

If the driver's door is opened without returning the ignition mode to "LOCK" (OFF) by pressing the engine switch, a buzzer sounds to warn you of this state.

- If you open the driver's door after pressing the engine switch to change the ignition mode to ACC, the interior buzzer beeps intermittently.
- The buzzer will stop sounding if you then push the engine switch twice, thus bringing it back the ignition mode to "LOCK" (OFF).

#### NOTE:

Whenever you leave the vehicle, make sure you have returned the ignition mode to "LOCK" (OFF) using the engine switch and then lock the doors. Without returning the ignition mode to "LOCK" (OFF), you cannot use a request switch or keyless push start system remote controller to lock the doors.

#### Steering lock warning buzzer

If the steering lock fails to engage due to a fault in the system when the ignition mode is turned to "LOCK" (OFF) by pressing the engine switch and then any door (including the tailgate) is opened or closed, the interior buzzer will warn you of this condition with repeated short beeps. If this happens, have the vehicle inspected by an authorised Maruti Suzuki workshop.

## Using the Transaxle

### Manual Transaxle

#### 5MT model

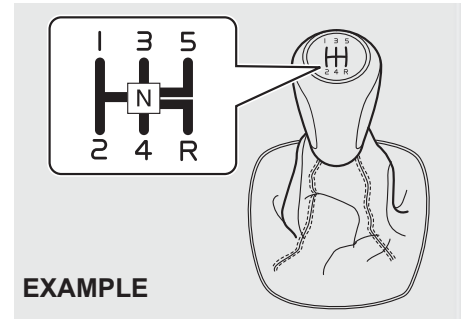

#### EXAMPLE

79MH0303

#### 6MT model

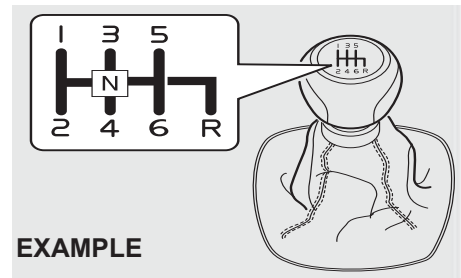

#### EXAMPLE

61MS2A004

### Starting off

To start off, depress the clutch pedal all the way to the floor and shift into 1st gear. After releasing the parking brake, gradually

## OPERATING YOUR VEHICLE

release the clutch. When you hear a change in the engine's sound, slowly press the accelerator while continuing to gradually release the clutch.

### Shifting

All forward gears are synchronized, which provides for quiet, and easy shifting. Always depress the clutch pedal all the way to the floor before shifting gears. Ensure that the engine rpm does not rise to the red zone of the tachometer.

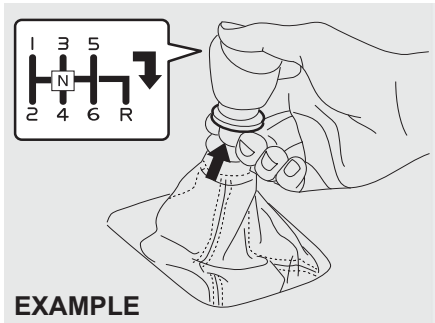

61MS2A005

Reverse gear (6MT model): while lifting up the ring, shift the gearshift lever to the rightmost position and engage the gear.

### Downshifting maximum allowable speeds

#### 5MT model

Downshifting	km/h (mph)
2nd to 1st	35 (22)
3rd to 2nd	65 (40)
4th to 3rd	100 (62)
5th to 4th	145 (90)*

#### 6MT model

Downshifting	km/h (mph)
2nd to 1st	40 (25)
3rd to 2nd	70 (43)
4th to 3rd	115 (71)
5th to 4th	160 (99)*
6th to 5th	200 (124)*

#### \*NOTE:

You may not accelerate to the maximum allowable speed because of the driving situation and/or the vehicle condition.

#### NOTICE

When downshifting to a lower gear, make sure not to downshift at the speed faster than the maximum allowable speeds for the next lower speed, or severe engine damage can result.

#### ⚠ WARNING

- Reduce your speed and downshift to a lower gear before going down a long or steep hill. A lower gear will allow the engine to provide braking. Avoid riding the brakes or they may overheat, resulting in brake failure.
- When driving on slippery roads, be sure to slow down before downshifting. Excessive and/or sudden changes in engine speed may cause loss of traction, which could cause you to lose control.

#### NOTICE

Make sure that the vehicle is completely stationary before you shift into reverse.

#### NOTICE

- To help avoid clutch damage, do not use the clutch pedal as a footrest while driving or use the clutch to keep the vehicle stationary on a slope. Depress the clutch fully when shifting.
- When shifting or starting off, do not race the engine. Racing the engine can shorten engine life and cause negative effect to smooth shifting.

### Cruise Control (if equipped)

The cruise control system allows you to maintain a steady speed without keeping your foot on the accelerator pedal. The controls for operating the cruise control system are on the steering wheel.

You can use the cruise control system with the following conditions:

- The gear position is in 3rd, 4th, 5th or 6th (if equipped).
- The vehicle speed is about 40 km/h (25 mph) or higher.

#### WARNING

To help avoid loss of vehicle control, do not use the cruise control system when driving in heavy traffic, on slippery or winding roads, or on steep downgrades.

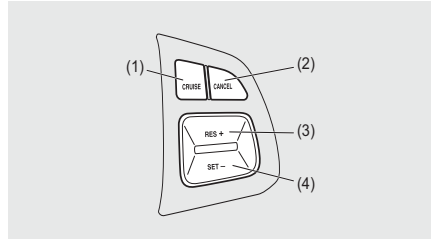

61MS416

- (1) "CRUISE" switch
- (2) "CANCEL" switch
- (3) "RES +" switch
- (4) "SET -" switch

### To Set Cruising Speed

- 1) Turn on the cruise control system by pushing the "CRUISE" switch (1). When the "CRUISE" indicator light comes on, you can set cruising speed.
- 2) Accelerate or decelerate to the desired speed.
- 3) Push the "SET -" switch (4) and the "SET" indicator light will turn on. Take your foot off the accelerator pedal and the set speed will be maintained.

#### WARNING

If the cruising speed is set by accident, you cannot decelerate and may lose control of the vehicle. This could lead to an accident, resulting in severe injury or death.

Turn off the cruise control system and make sure the "CRUISE" indicator light is off when the system is not in use.

### “CRUISE” Indicator Light



52D113

When you push the “CRUISE” switch, the system is on and a “CRUISE” indicator light on the instrument cluster will be on.

### “SET” Indicator Light



65D474

When the vehicle’s speed is controlled by the cruise control system, a “SET” indicator light on the instrument cluster will be on.

### To Change Speed Temporarily

When the cruising speed is maintained, you can temporarily accelerate or decelerate.

To accelerate, depress the accelerator pedal. When you take your foot off the pedal, your vehicle will return to the set speed.

To decelerate, depress the brake pedal. The set speed will be canceled and “SET” indicator light will go off.

To resume the previously set speed, push the “RES +” switch (3) and turn on the “SET” indicator light again when vehicle speed is above 40 km/h (25 mph). The vehicle will accelerate to and maintain the previously set speed.

### To Change Cruising Speed

#### Using the accelerator pedal

To reset at a faster cruising speed, accelerate to the desired speed using the accelerator pedal and push the “SET –” switch (4). The new speed will be maintained.

#### Using the brake pedal

To reset at a slower cruising speed, decelerate to the desired speed using the brake pedal and push the “SET –” switch (4). The new speed will be maintained.

#### NOTE:

*When the brake pedal is depressed, the “SET” indicator light goes off until the cruising speed is reset.*

#### Using the “RES +” switch or the “SET –” switch

To reset at a faster cruising speed, press repeatedly or hold push the “RES +” switch (3). Vehicle speed will steadily increase. When you release the switch, the new speed will be maintained.

To reset at a slower cruising speed, press repeatedly or hold push the “SET –” switch (4) until the vehicle has slowed to the desired speed, then release the switch. The new speed will be maintained.

#### NOTE:

*You can adjust the set speed by approximately 1.6 km/h (1.0 mph) by pushing the “RES +” switch (3) or the “SET –” switch (4) quickly.*

### Cancellation of the Cruise Control

The “SET” indicator light will go off and the cruise control will be canceled temporarily with following procedures:

- Push the “CANCEL” switch (2).
- Depress the brake pedal.
- Depress the clutch pedal.
- The vehicle speed falls more than about 20 percent from the set speed.
- Any time the vehicle speed falls below 40 km/h (25 mph).

To resume the previously set speed, push the “RES +” switch (3) and turn on the “SET” indicator light. Besides, the vehicle speed has to be above 40 km/h (25 mph) when the vehicle is not in the above conditions.

To turn off the cruise control system, push the “CRUISE” switch (1) and make sure the “CRUISE” indicator light is off.

Also, if the malfunction indicator light in the instrument cluster comes on or blinks, the cruise control system will be turned off.

**NOTE:**

*If you turn off the cruise control system, the previously set speed in the memory is cleared. Reset your cruising speed again.*

### Parking Sensors (if equipped)



61MM0A192

(1) Symbol representing an obstacle detected by parking sensor\*

- \* This symbol represents an obstacle that is located to the right rear of the vehicle.
- The parking sensor system uses ultrasonic sensors to detect obstacles near the rear bumper. If obstacles are sensed while you are parking or moving the vehicle slowly, the system warns you by sounding a buzzer and displaying symbols representing the obstacles on the information display in the instrument cluster.
- The system emits an ultrasonic wave and the relevant sensor detects the return of the wave reflected by an obstacle. The system measures the time taken by the ultrasonic wave to reach the obstacle and return from it, from which it determines the obstacle’s position.
- The parking sensor function can be used when you press the engine switch to

change the ignition mode to “ON”, the gearshift lever is in “R” position and the parking sensor switch is in the “ON” position. This function is helpful in the following cases: pulling over to the curb; parallel-parking the vehicle; steering the vehicle into a garage; driving along an alley; and moving slowly in a place with obstacles.

**⚠ WARNING**

- **The parking sensor warns you of obstacles with buzzers and by showing you the location of the obstacles on the information display. However, you must still pay full attention yourself while driving.**
- **The sensors can detect obstacles only within a limited area and only when the vehicle is moving within a limited speed range. So, in tricky areas, you must move the vehicle slowly while checking around it using your direct vision or rearview mirrors. There is increased risk of an accident if you control the vehicle relying only on the parking sensor.**

**NOTICE**

**Parking sensors are only for driver’s assistance**

## OPERATING YOUR VEHICLE

### Sensor Locations On the rear bumper

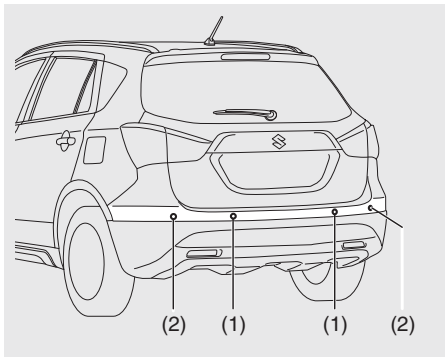

64MS170

- (1) Rear center sensors (2 places)
- (2) Rear corner sensors (2 places)

#### NOTICE

- Avoid hitting the sensor areas or directing the nozzle of a high-pressure car washer onto the sensor areas. Otherwise, the sensors may be damaged.
- If the bumper hits a hard object, the sensors on it may not work properly. If this occurs, have the sensors inspected by an authorised Maruti Suzuki workshop.

### Working sensors

The sensors that work depends on the position of the gearshift lever as follows:

Gearshift lever position		R	N, 1st – 5th or 6th
Rear sensors	Center	On	Off
	Corner	On	Off

### Approximate areas where obstacles can be detected

#### EXAMPLE

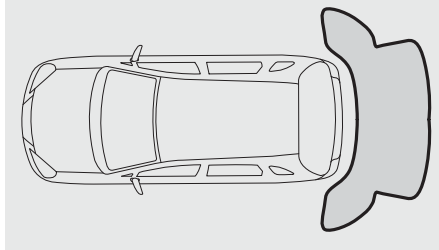

64MS007

- Any obstacle within about 20 cm (8 in) from the sensor or just below the sensor is not detectable.
- The sensors can detect an obstacle up to about 1.5 m (5 ft) from the rear of vehicle.

#### ⚠ WARNING

- Under the following conditions, the parking sensor system may not work normally because the sensors cannot detect obstacles correctly.
  - Sensors are covered with mud, ice or other materials. (Such materials must be removed for normal operation.)
  - Sensors are wet from water splashes or heavy rain.
  - Sensors are covered by a hand, sticker, accessory, etc.
  - There is an accessory or other object attached within the sensor's sensing area.
  - Items such as tow hooks, commercially available corner poles, radio antenna, etc. are installed on the bumper.
  - The height of the bumper is changed due to alteration to the suspension or other causes.
  - The sensor areas are extremely hot from direct sunlight or cold due to freezing weather.
  - The vehicle is on a rough surface, slope, gravel road or grass field.
  - The vehicle is at a steep angle.
  - Sensors have intercepted ultrasonic noise from another vehicle's horn, engine air braking system (large vehicles), or parking sensor.

(Continued)

**⚠ WARNING**

(Continued)

- Obstacles are too close to the sensors.
- Sensors are at an angle to a highly reflective object such as glass. (Ultrasonic waves are not reflected back from the obstacle.)
- Sensors may not be able to correctly detect the following types of obstacles:
  - Objects made of a thin material like wire netting and ropes
  - Square-shaped curbstones or other objects with sharp edges
  - Tall objects with a large upper part like a road sign
  - Low-profile objects such as curbstones
  - Sound-absorbing objects such as cotton and snow

**NOTE:**

- *Thin poles or obstacles lower than the sensors may become undetectable as the vehicle moves closer to them even if they have been detected from longer distances.*
- *The distance calculated by the system to a road sign or similar obstacle may be shorter than the actual distance.*

## OPERATING YOUR VEHICLE

### How to Use the Parking Sensor

#### Parking sensor switch

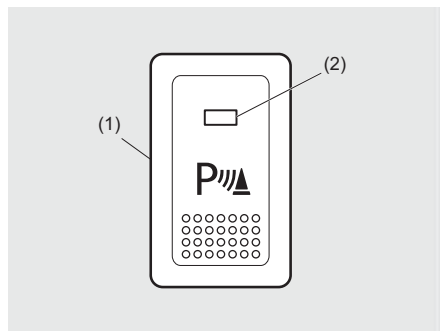

61MS403

- (1) Parking sensor switch  
(2) Indicator

- When the ignition mode is “ON” and the indicator light in the parking sensor switch is on, indicating that the parking sensor is ready for operation under the following conditions:
  - The gearshift lever is in the “R” position.
  - The vehicle’s forward moving speed is not more than approx. 9 km/h (6 mph) when decelerating the vehicle such as for parking.
  - The vehicle’s forward moving speed is not more than approx. 13 km/h (9 mph) when accelerating.
- To deactivate the parking sensor, push the parking sensor switch and make sure the indicator light goes off.

Switch position	State
<p><b>EXAMPLE</b></p>	<p><b>ON</b></p> <ul style="list-style-type: none"> <li>• When the indicator light is on and all necessary conditions are met, system becomes ready for operation.</li> </ul>
<p><b>EXAMPLE</b></p>	<p><b>OFF</b></p> <ul style="list-style-type: none"> <li>• The system does not operate. Push the switch to turn off the indicator if you do not wish to use the parking sensor.</li> </ul>

**NOTE:**

*If you push the parking sensor switch from the OFF to ON position when the ignition mode has been changed to ON by pressing the engine switch, the inside buzzer sounds.*



**Obstacle Indication by Parking Sensor**

**EXAMPLE**



(2) (1) (2)

64MS008

- (1) Obstacle detected by rear center sensors
- (2) Obstacle detected by rear corner sensors

Upon detecting an obstacle, the parking sensor causes an interior buzzer to sound and a symbol representing the obstacle appears on the information display in the instrument cluster.

- A different symbol is displayed depending on the direction and distance of the obstacle.
- A buzzer located behind the rear seat sounds when a sensor at the rear detects an obstacle.
- Warnings when obstacles are detected by corner sensors

Distance (approx.)	Buzzer	Symbol
45 – 60 cm (18 – 24 in)	Short beeps at short intervals	Three lines
35 – 45 cm (14 – 18 in)	Short beeps at very short intervals	Two lines
Less than 35 cm (14 in)	Continuous beep	One line

- Warnings when obstacles are detected by center sensors

Distance (approx.)	Buzzer	Symbol
60 – 150 cm (24 – 59 in)	Short beeps at long intervals	Three lines
45 – 60 cm (18 – 24 in)	Short beeps at short intervals	
35 – 45 cm (14 – 18 in)	Short beeps at very short intervals	Two lines
Less than 35 cm (14 in)	Continuous beep	One line

**NOTE:**

- Symbols are displayed with a short delay after the detection of obstacles.
- If the system detects multiple obstacles simultaneously, the display shows all of their positions using the corresponding symbols. However, the buzzers will sound only for the nearest obstacles.

## OPERATING YOUR VEHICLE

### Set Sensors

You can select either the normal or trailer mode of the parking sensor via the information display. Refer to “Information Display” in the “BEFORE DRIVING” section.

#### Normal mode

All sensors operate. Use this mode under normal conditions.

#### Trailer mode



The rear corner and rear center sensors are inhibited from operating. Use this mode when towing a trailer.

### NOTICE

**Make sure the normal mode is selected with the parking sensor when steering the vehicle into a garage. If the parking sensor is left in the trailer mode, the rear corner and rear center sensors are not functioning.**

### Warning and Indicator Messages

If there is a problem or warning regarding the parking sensor system, a message is displayed on the information display in the instrument cluster, and a symbol blinks and the buzzer sounds. If a message is displayed, follow its instruction.

Message	Symbol	Buzzer	Probable cause and remedy
	Two blinking lines in a sensor location.	Series of double beeps	There may be problem with the parking sensor system. Have your vehicle inspected by an authorised Maruti Suzuki workshop.
	One blinking line in a sensor location.	Series of single beeps	The indicated sensor is contaminated. Wipe it clean with a soft cloth.

## Rearview Camera (if equipped)

When the gearshift lever is shifted to the “R” position while the ignition switch is in the “ON” position or the ignition mode is ON, the rearview camera system automatically shows the view behind the vehicle on the display.

### WARNING

The distance viewed in the rearview camera may differ from the actual distance according to the condition of road or the load the vehicle is carrying. Since the camera display area is also limited, backing up by only looking at the display may cause an accident or a collision with an object.

The rearview camera cannot replace the driver’s attention. The driver alone is responsible for parking and similar driving maneuvers.

- Use the rearview camera only to provide driving assistance.
- Always drive carefully confirming the safety of the rear and the surrounding conditions by looking directly with your eyes and using the rear view mirror.
- Make sure that the tailgate is securely closed when backing up.

### NOTICE

If you use the rearview camera for a long time when the ignition switch is in the “ON” position or the ignition mode is ON, but the engine is not running, the battery may discharge.

Do not leave the ignition switch in the “ON” position or the ignition mode ON for a long time when the engine is not running.

## Rearview Camera Location

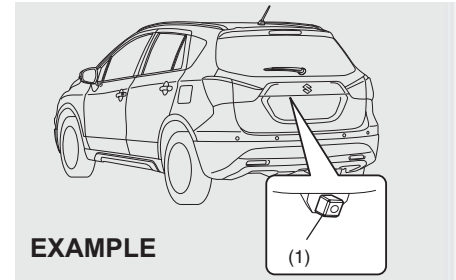

EXAMPLE

64MS144

(1) Rearview camera

The rearview camera is installed beside the license plate light.

### NOTICE

The rearview camera is a precision instrument. If you strike the camera, it may break and cause damage resulting in fire or a malfunction.

- Do not strike the camera.
- Do not remove snow or mud on the camera lens with a stick.

## OPERATING YOUR VEHICLE

### NOTICE

If water enters the rearview camera, it may cause a malfunction or catch fire.

Do not use high pressure water around the camera.

### NOTICE

The camera lens is hard coated to prevent damage or discoloration. Damage or discoloration of lens may obscure the image.

- Do not use a brush to clean lens.
- Do not use alcohol, benzene or thinner to clean the lens.
- Do not use wax on the camera lens.

### NOTE:

If body wax does get on the camera lens, wipe off the wax with a clean cloth dampened with mild detergent diluted with water, then wipe with a dry cloth.

### How to Use Rearview Camera

- 1) Turn the ignition switch to the "ON" position or press the engine switch to change the ignition mode to ON.
- 2) Shift the gearshift lever in the "R" position.
  - The display automatically shows the view behind the vehicle.
  - When the gearshift lever is shifted from "R" to another gearshift lever position, the display returns to the previous display.

### NOTE:

- Images shown on the display from the rearview camera are reversed images (mirror images).
- The colors of objects on the rearview camera may differ from the actual object colors.
- The rearview camera display has first priority in any display mode. However, the rearview camera display does not show the rear view while the system is initializing.

### Display Range of Rearview Camera

The rearview camera display shows the area behind the rear end of the tailgate. The display cannot show objects which are close to the bumper or under the bumper. The rearview camera display cannot show obstacles which are higher than the camera. Upper parts of tall objects such as road signs cannot be viewed on the display.

### Example of display range of rearview camera

#### EXAMPLE

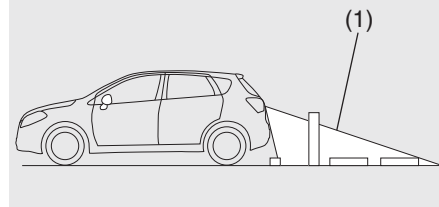

61MM0A015

#### EXAMPLE

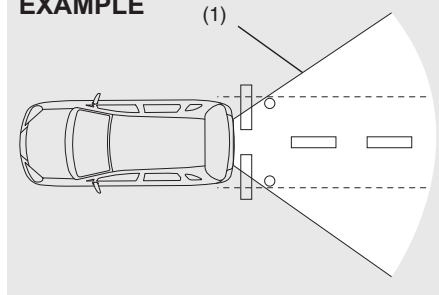

61MM0B012

(1) Display range

### NOTE:

- Images shown on the display from the rearview camera are reversed images (mirror images).

- The colors of objects on the rearview camera may differ from the actual object colors.
- The rearview camera display may be difficult to see under the following conditions, but this is not a system malfunction.
  - In dark areas, on a rainy day or at night.
  - When the temperature around the lens is too high/low, or the camera is wet such as on a rainy day or during periods of high humidity (dew condensation may occur on the camera lens).
  - When a foreign object such as mud or a drop of water is stuck around the camera lens.
  - When strong light directly enters the camera (vertical lines may be seen on the display).
  - Under fluorescent light. (The display may flicker.)
  - When the outside temperature is low (the image on the display may be darkened).

**Example of rearview camera screen indication**

The distance viewed in the rearview camera may differ from the actual distance according to the condition of the road or the load the vehicle is carrying.

**Uphill Incline behind the Vehicle**

**EXAMPLE**

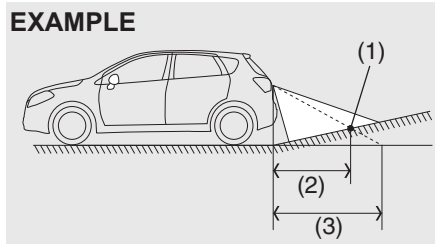

61MM0A016

- (1) Object
- (2) Actual distance
- (3) Distance on the display

When there is an uphill incline behind the vehicle, the object shown on the display appears farther away than the actual distance.

**Downhill Incline behind the vehicle**

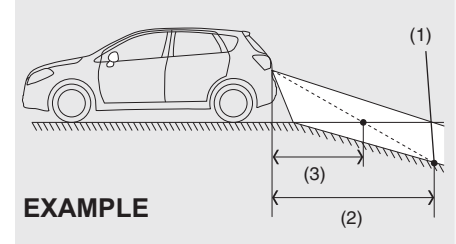

61MM0A017

- (1) Object
- (2) Actual distance
- (3) Distance on the display

When there is a downhill incline behind the vehicle, the object shown on the display appears closer than the actual distance.

## OPERATING YOUR VEHICLE

**If the rear view from the rearview camera is not shown or there is a poor image**

- If the rear view from the rearview camera is not shown.
  - Check to make sure that the ignition switch is in the “ON” position or the ignition mode is “ON”.
  - Check to make sure that the gearshift lever is shifted to the “R” position.
- If the image from the rearview camera is poor.
  - Check to make sure that the camera lens is not dirty.
  - Check to make sure that light from the sun or the beam of the headlights from the vehicle behind is not shining directly into the lens.

If the rearview camera system is still not working properly after checking the above, have the system inspected by an authorised Maruti Suzuki workshop as soon as possible.

## Braking

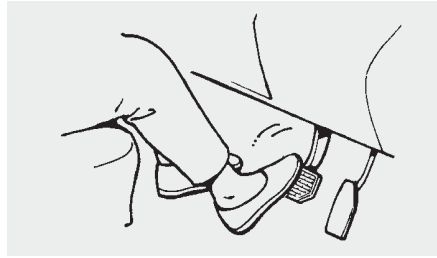

60G165S

The distance needed to bring any vehicle to a halt increases with the speed of the vehicle. The braking distance needed, for example, at 60 km/h (37 mph) will be approximately 4 times greater than the braking distance needed at 30 km/h (19 mph). Start to brake the vehicle when there is plenty of distance between your vehicle and the stopping point, and slow down gradually.

### **⚠ WARNING**

**If water gets into the brake devices, brake performance may become poor and unpredictable. After driving through water or washing the under side of the vehicle, test the brakes while driving at a slow speed to see if they have maintained their normal effectiveness. If the brakes are less effective than normal, dry them by driving slowly until the brakes have regained their normal effectiveness.**

### **Power-Assisted Brakes (if equipped)**

Your vehicle has power-assisted brakes. If power assistance is lost due to a stalled engine or other failures, the system is still fully operational on reserve power and you can bring the vehicle to a complete stop by pressing the brake pedal once and holding it down. The reserve power is partly used up when you depress the brake pedal and reduces each time the pedal is pressed. Apply smooth and even pressure to the pedal. Do not pump the pedal.

### **⚠ WARNING**

**Even without reserve power in the brake system, you can still stop the vehicle by pressing the brake pedal harder than normally required. However, the stopping distance may be longer.**

**Brake Assist System (if equipped)**

When you slam the brakes on, the brake assist system judges as an emergency stop and provides more powerful braking for a driver who cannot hold down the brake pedal firmly.

**NOTE:**

If you quickly and forcefully depress the brakes, you may hear a clicking sound in the brake pedal. This is normal and indicates that the brake assist system is activated properly.

**Anti-Lock Brake System (ABS)  
(if equipped)**

ABS will help in avoiding locking of the wheel by electronically controlling braking pressure. It will also help you maintain steering control when braking on slippery surfaces or when braking hard"

The ABS works automatically, so you do not need any special braking technique. Just push the brake pedal down without pumping. The ABS will operate whenever it senses that the wheels are locking up. You may feel the brake pedal moves a little while the ABS is operating.

**NOTE:**

The ABS will not work if vehicle speed is under about 10 km/h (6 mph).

**⚠ WARNING**

- On some types of loose surfaces (such as gravel, snow-covered roads, etc.) the stopping distance required for an ABS-equipped vehicle may be slightly greater than for a comparable vehicle with a conventional brake system. With a conventional brake system, skidding tires are able to plow the gravel or snow layer, shortening the stopping distance. ABS minimizes this resistance effect. Allow for extra stopping distance when driving on loose surfaces.
- On regular paved roads, some drivers may be able to obtain slightly shorter stopping distances with conventional brake systems than with ABS.
- In both of the above conditions, ABS will still offer the advantage of helping you maintain directional control. However, remember that ABS will not compensate for bad road or weather conditions or poor driver judgment. Use good judgment and do not drive faster than conditions will safely allow.

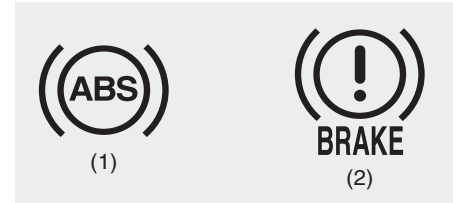

63J081

- (1) ABS warning light  
(2) Brake system warning light

### WARNING

- If the ABS warning light (1) on the instrument panel comes on and stays on while driving, there may be a problem with the ABS system. Ask your authorised Maruti Suzuki workshop to inspect the ABS system immediately. If the ABS system becomes inoperative, the brake system will function as an ordinary brake system that has no ABS.
- If the ABS warning light (1) and the Brake system warning light (2) on the instrument panel simultaneously stays on or comes on when driving, both anti-lock function and rear brake force control function (proportioning valve function) of the ABS system may have failed. If so, the rear wheels may easily skid or the vehicle can even spin in the worst case when braking on a slippery road or when hard braking even on a dry paved road. Ask your authorised Maruti Suzuki workshop to inspect the ABS system immediately. Drive carefully, avoiding hard braking as much as possible.

### How the ABS Works

A computer continuously monitors wheel speed. The computer compares the changes in wheel speed when braking. If the wheels slow suddenly, indicating a skidding situation, the computer will change braking pressure several times each second to prevent the wheels from locking. When you start your vehicle or when you accelerate after a hard stop, you may hear a momentary motor or clicking noise as the system resets or checks itself." This is absolutely normal and indicates that ABS is functioning properly"

### WARNING

The ABS may not work properly if tires or wheels other than those specified in the owner's manual are used. This is because the ABS works by comparing changes in wheel speed. When replacing tires or wheels, use only the size and type specified in this owner's manual.



## DRIVING TIPS

Running-in .....	4-1
Catalytic Converter .....	4-1
Improving Fuel Economy .....	4-2
Highway Driving .....	4-3
Driving on Hills .....	4-3
Driving on Slippery Roads .....	4-4
Do's and Dont's for Safe Driving.....	4-6

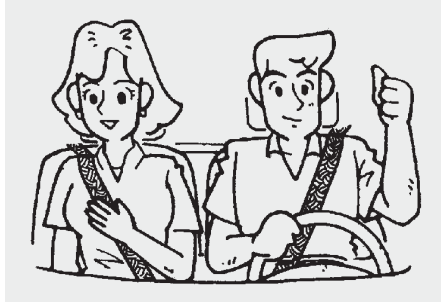

52D078

### WARNING

- **WEAR YOUR SEAT BELTS AT ALL TIMES.** Even though air bags are equipped at the front seating positions, the driver and all passengers should be properly restrained at all times, using the seat belts provided. Refer to the “Seat Belts and Child Restraint Systems” section for instructions on proper use of the seat belts.
- Never drive while under the influence of alcohol or other drugs. Alcohol and drugs can seriously impair your ability to drive safely, greatly increasing the risk of injury to yourself and others. You should also avoid driving when you are tired, sick, irritated, or under stress.

## Running-in

### NOTICE

The future performance and reliability of the engine depends on the care and restraint exercised during its early life. It is especially important to observe the following precautions during the initial 960 km (600 miles) of vehicle operation.

- After starting, do not race the engine. Warm it up gradually.
- Avoid prolonged vehicle operation at a constant speed. Moving parts will break in better if you vary your speed.
- Start off from a stop slowly. Avoid full throttle starts.
- Avoid hard braking, especially during the first 320 km (200 miles) of driving.
- Do not drive slowly with the trans-axle in a high gear.
- Drive the vehicle at moderate engine speeds.
- Do not tow a trailer during the first 960 km (600 miles) of vehicle operation.

## Catalytic Converter

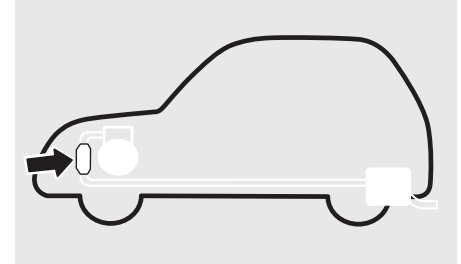

80G106

The purpose of the catalytic converter is to minimize the amount of harmful pollutants in your vehicle's exhaust. Use of leaded fuel in vehicles equipped with catalytic converters is prohibited, because lead deactivates the pollutant-reducing components of the catalyst system.

The converter is designed to last the life of the vehicle under normal usage and when unleaded fuel is used. No special maintenance is required on the converter. However, it is very important to keep the engine properly tuned. Engine misfiring, which can result from an improperly tuned engine, may cause overheating of the catalyst. This may result in permanent heat damage to the catalyst and other vehicle components.

**NOTICE**

To minimize the possibility of catalyst or other vehicle damage:

- Maintain the engine in the proper operating condition.
- In the event of an engine malfunction, particularly one involving engine misfire or other apparent loss of performance, have the vehicle serviced promptly.
- Do not turn off the engine or interrupt the ignition when the transaxle is in gear and the vehicle is in motion.
- Do not try to start the engine by pushing or towing the vehicle, or coasting down a hill.
- Do not idle the engine with any spark plug wires disconnected or removed, such as during diagnostic testing.
- Do not idle the vehicle for prolonged periods if idling seems rough or there are other malfunctions.
- Do not allow the fuel tank to get near the empty level.



54G584S

**⚠ WARNING**

Be careful where you park and drive; the catalytic converter and other exhaust components can get very hot. As with any vehicle, do not park or operate this vehicle in areas where combustible materials such as dry grass or leaves can come in contact with hot exhaust system components.

**Improving Fuel Economy**

The following instructions will help you improve fuel economy.

**Avoid excessive idling**

If you are to wait for more than a minute while you are parked, stop the engine and start it again later. When warming up a cold engine, allow the engine to idle until the temperature gauge pointer comes up to the "C" position (if the idling is not prohibited). In this position, the engine is sufficiently warm for starting off.

**Avoid fast starts**

Fast starts away from lights or stop signs will consume fuel unnecessarily and shorten engine life. Start off slowly.

**Avoid unnecessary stops**

Avoid unnecessary deceleration and stopping. Try to maintain a slow, steady speed whenever possible. Slowing down and then accelerating again uses more fuel.

**Keep a steady cruising speed**

Keep as constant a speed as road and traffic conditions will permit.

**Keep weight to a minimum**

The heavier the load, more the fuel vehicle consumes. Take out any luggage or cargo when it is not necessary.

**Keep tire pressures correct**

Underinflation of the tires can waste fuel due to increased running resistance of the tires. Keep your tires inflated to the correct

## DRIVING TIPS

pressure shown on the label on the driver's side door or the driver's door lock pillar.

### Highway Driving

When driving at highway speeds, pay attention to the following:

- Stopping distance progressively increases with vehicle speed. Apply the brakes far enough ahead of the stopping point to allow for the extra stopping distance.
- On rainy days, hydroplaning can occur. Hydroplaning is the loss of direct contact between the road surface and the vehicle's tires due to a water film forming between them. Steering or braking the vehicle while hydroplaning can be very difficult, and loss of control can occur. Keep speed down when the road surface is wet.
- At high speeds, the vehicle may be affected by side winds. Therefore, reduce speed and be prepared for unexpected buffeting, which can occur at the exits of tunnels, when passing by a cut of a hill, or when being overtaken by large vehicles, etc.

## Driving on Hills

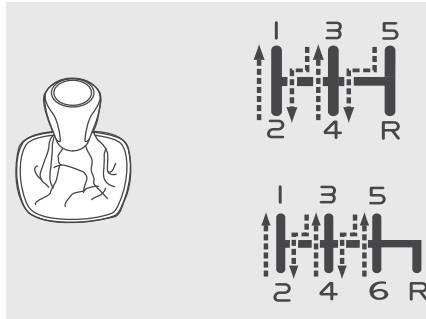

64MS171

- When climbing steep hills, the vehicle may begin to slow down and show a lack of power. If this happens, you should shift to a lower gear so that the engine will again be operating in its normal power range. Shift rapidly to prevent the vehicle from losing momentum.
- When driving down a hill, the engine should be used for braking by shifting to next lower gear.

### NOTICE

When descending a down hill, **NEVER** turn the ignition key to the "LOCK" position or press the engine switch to change the ignition mode to LOCK (OFF). Emission control system damage may result.

### ⚠ WARNING

Try not to hold the brake pedal down too long or too often while going down a steep or long hill. This could cause the brakes to overheat, resulting in reduced braking efficiency. Failure to take this precaution could result in loss of vehicle control.

## Driving on Slippery Roads

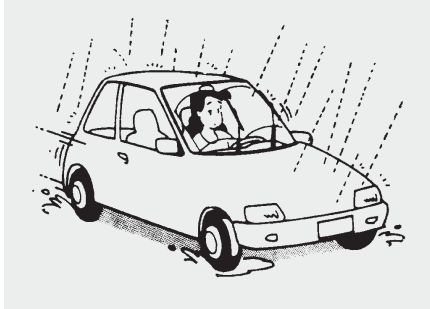

60G089A

Under wet road conditions you should drive at a lower speed than on dry roads due to possible slippage of tires during braking. When driving on icy, snow-covered, or muddy roads, reduce your speed and avoid sudden acceleration, abrupt braking, or sharp steering movements.

## Tire Chains

Tire chains should only be used if they are needed to increase traction or are required by law. Make sure that the chains you use are the correct size for your vehicle's tires. Also make sure that there is enough clearance between the fenders and the chains as installed on the tires.

Install the chains on the front tires tightly, according to the chain manufacturer's instructions. Retighten the chains after driving about 1.0 km (1/2 mile) if necessary. With the chains installed, drive slowly.

### NOTICE

- **If you hear the chains hitting against the vehicle body while driving, stop and tighten them.**
- **If your vehicle is equipped with full wheel caps, remove the wheel caps before installing the chains or the wheel caps can be damaged by the chain bands.**

## If Your Vehicle Gets Stuck

If your vehicle gets stuck in snow, mud, or sand, follow the directions below:

- 1) Shift the transaxle back and forth between first gear and reverse. This will create a rocking motion which may give you enough momentum to free the vehicle. Press gently on the accelerator to keep wheel spinning to a minimum wheel rpm. Remove your foot from the accelerator while shifting. Do not race the engine. Excessive wheel spin will cause the tires to dig deeper, making it more difficult to free the vehicle.
- 2) If your vehicle remains stuck after a few minutes of rocking, we recommend you to consult your authorised Maruti Suzuki workshop or a roadside assistance service. If a towing service is not available in an emergency, your vehicle may be temporarily towed by a towing cable or chain secured to the towing hook either on the front of the vehicle or on the rear of the vehicle. Refer to "Frame Hooks" in the "OTHER CONTROLS AND EQUIPMENT" section.

### ⚠ WARNING

Do not allow anyone to stand near the vehicle when you are rocking it, and do not spin the wheels faster than an indicated 40 km/h (25 mph) on the speedometer. Personal injury and/ or vehicle damage may result from spinning the wheels too fast.

### NOTICE

Do not continue rocking the vehicle for more than a few minutes. Prolonged rocking can cause engine overheating or transaxle damage.

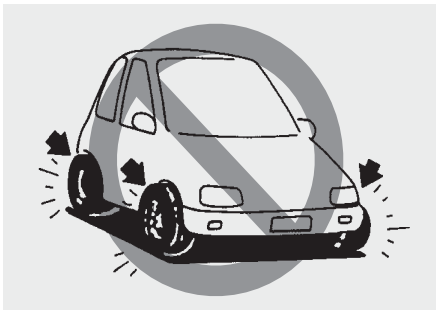

54G638

### NOTICE

- When driving on wet roads, avoid driving through large amount of standing water on the road. Large amount of water entering the engine compartment may cause damage to the engine and or electrical components.
- If stuck in deep water, do not start the engine.
- Water is incompressible substance, water inside engine will damage the engine.

### ⚠ WARNING

In addition to following the driving tips in this section, it is important to observe the following precautions.

- Make sure your tires are in good condition and always maintain the specified tire pressure. Refer to “Tires” in the “INSPECTION” AND “MAINTENANCE” section for details.
- Never use oversized tires or special shock absorbers and springs to raise (jack up) your vehicle. This will change the handling characteristics. Oversized tires may also rub against the fender over bumps, causing vehicle damage or tire failure
- After driving through water, test the brakes while driving at a slow speed to see if they have maintained their normal, dry them by repeatedly applying the brakes while driving slowly until the brakes have regained their normal effectiveness.
- Do not use tires other than those specified by MARUTI SUZUKI. Never use different sizes or types of tires on the front and rear wheels. For information regarding the specified tires, refer to the Tire information Label located on the driver’s door lock pillar.

## Do's and Dont's for Safe Driving

Exercise care in handling your vehicle. Be conscious of not only your own safety but also the safety of others on the road, and thus enjoy the best and most comfortable driving experience.

This section contains basic rules for safe driving. Read it carefully for good understanding of the content so that you can enjoy safe and pleasant driving in your vehicle.

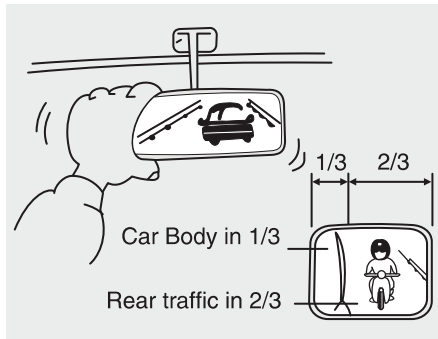

### Starting

- 1) Adjust the driver's seat for the proper driving posture.
- 2) Adjust the rear view mirror so as to obtain the best possible rear view.
- 3) Before moving off, look forward and back to confirm safety.

- 4) Don't start quickly, since it is dangerous and wastes fuel.

### General driving

- 1) Be sure to stop before the stop light and stop sign. When moving into the intersection without any traffic lights or signs, drive slowly to confirm safety.

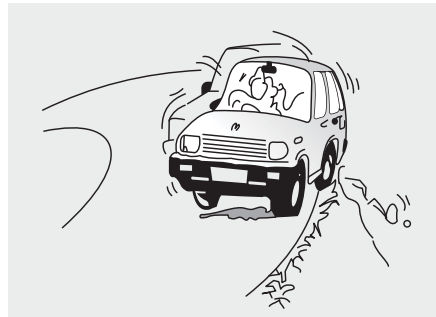

72F-08-002

- 2) Always follow other vehicles at a safe distance in order to prevent a rear-end collision, in case the vehicle ahead make a sudden stop.
- 3) Turn ON the turn signal at least 30 meters before making a turn or changing the lane so as not to be hit from behind.
- 4) Before entering a corner, decelerate to a safe speed. Don't apply brakes during cornering, or a cornering skid may occur.

- 5) When overtaking other vehicles, watch out for the oncoming vehicle and carefully confirm the safety.
- 6) Don't attempt zigzag driving which will hinder your control over the vehicle and cause an accident.

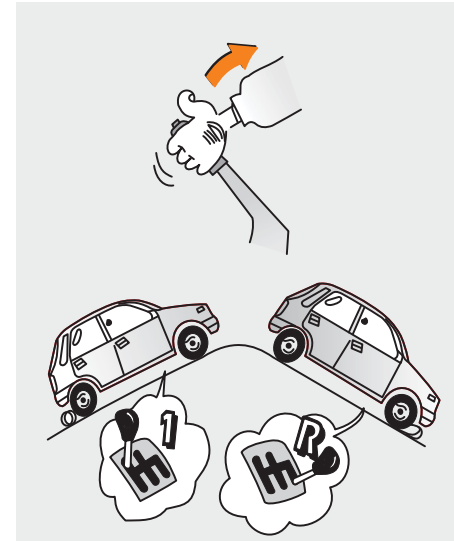

72F-08-011

### Braking

- 1) Use the parking brake when parking your vehicle and shift the gear shift lever into the first gear or reverse gear position for the sake of safety.

## DRIVING TIPS

- 2) Don't use hand-braking unless unavoidable. It causes the vehicle to skid and a rear-end collision occur. It is especially dangerous when the tyres are worn, for they allow a larger skid.



72F-08-012

Use foot brake in three stages

1. Warn the vehicle behind you
  2. Gradually apply the brake.
  3. Bring the vehicle to a halt.
- 3) When driving on a downhill, try not to apply the brake but use the engine brake effectively. Overuse of the foot brake may result in total brake failure.
  - 4) Avoid reckless high speed driving and try to drive at a safe speed suitable for the road conditions while maintaining a constant speed.

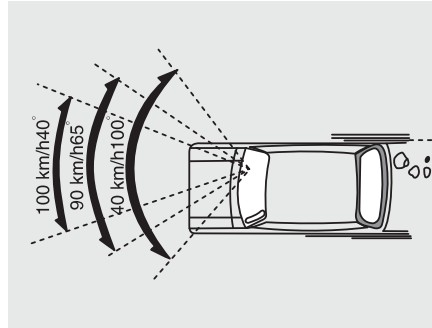

72F-08-015

- 5) The higher the speed, the narrower the driver's visual range becomes. In such a state, it is difficult to anticipate any hazard and the driver feels much fatigued.
- 6) Never do sharp handling during high speed driving. You will lose your control over your vehicle.
- 7) When overtaking or changing the lane while driving at a high speed, keep an ample vehicle-to-vehicle distance.

### Long distance driving

- 1) Be sure to perform safety checks before starting a trip.
- 2) Take rest at certain intervals to prevent an accident which may occur when you are sleepy or tired.



72F-08-020

### Night time driving

- 1) Drive more slowly at night than in the daytime, for the visual range is restricted at night.
- 2) Don't overtake other vehicles at night. Darkness bothers your sense of speed and hinders your judgment on the vehicle-to-vehicle distance.
- 3) Don't use the high headlight beam unless its use is inevitable. Its dazzle may blitz the driver of the oncoming vehicle, thus causing an accident.
- 4) Always keep the window glasses clean. Don't operate the windshield wiper



when the windshield glass is dry or the wiper blade and glass may get damaged.

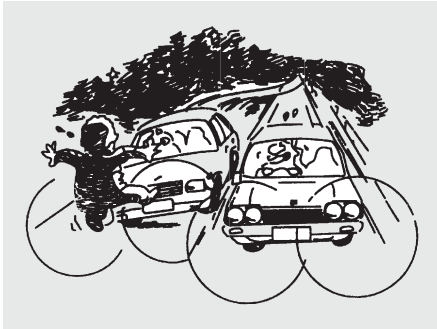

72F-08-021

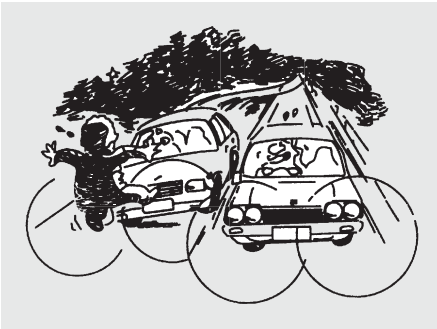

72F-08-022

## Margin For Safety

It is important to allow yourself a margin for safety during driving so that you can cope with erroneous or unexpected driving of other drivers. For that, observe the following.

- Drive at a safe speed.
- Maintain a sufficient distance between your vehicle and the vehicle ahead.
- Don't force yourself to overtake other vehicles.
- Don't make quick start, hard steering or sudden stops.
- Allow an ample time in the driving schedule.
- Observe traffic rules and regulations.

## Conclusion

A perfect driver does not exist. The endeavour of every motorist should be to strive for perfection. Safety consciousness not only ensures your safety and the safety of other road users, it also helps reduce the wear and tear on your vehicle, prolongs its life, gives more mileage and ensures a comfortable driving experience.

**Follow the do's and don'ts listed, and driving will never be the same again.**

**MEMO**

-----

-----

-----

-----

-----

-----

-----

-----

-----

-----

-----

-----

-----

-----

-----

-----

-----

-----

-----

-----

-----

-----

-----

## OTHER CONTROLS AND EQUIPMENT

Fuel Filler Door / Cap .....	5-1
Engine Hood .....	5-2
Sun Visor .....	5-4
Interior Light .....	5-5
Accessory Socket .....	5-7
Assist Grips (if equipped) .....	5-8
Glove Box .....	5-9
Overhead Console (if equipped) .....	5-9
Cup Holder and Storage Area .....	5-11
Footrest (if equipped) .....	5-14
Floor Mats (if equipped) .....	5-14
Luggage Compartment Hooks .....	5-15
Luggage Compartment Cover (if equipped) .....	5-15
Luggage Compartment Board .....	5-15
Roof Rails or Roof Rack Anchors (if equipped) .....	5-16
Frame Hooks .....	5-17
Air Conditioning System .....	5-20
Manual Heating and Air Conditioning System .....	5-21
Automatic Heating and Air Conditioning System (Climate Control) .....	5-26
Radio Antenna .....	5-31
Installation of Radio Frequency Transmitters .....	5-31
Audio System (if equipped) .....	5-32

## OTHER CONTROLS AND EQUIPMENT

### Fuel Filler Door / Cap

#### EXAMPLE

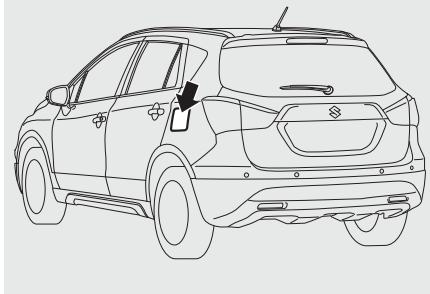

64MS137

#### EXAMPLE

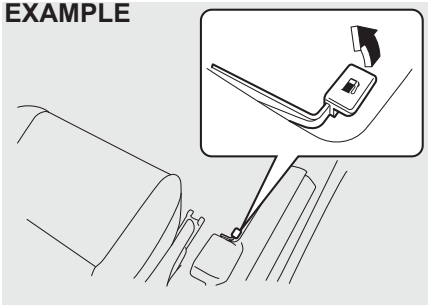

64MS070

The fuel filler cap is located on the left rear side of the vehicle. The fuel filler lid can be unlocked by pulling up the opener lever located on the outboard side of the driver's seat and locked by simply closing the door.

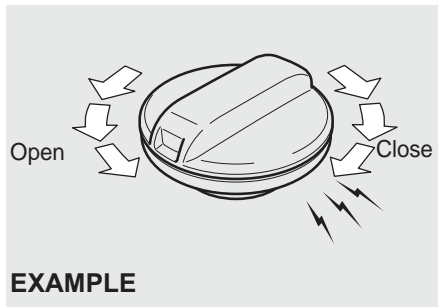

57L51093

To remove the fuel filler cap:

- 1) Open the fuel filler lid.
- 2) Remove the cap by turning it counter-clockwise.

#### CAUTION

**Remove the fuel filler cap slowly. The fuel may be under pressure and may spray out, causing injury.**

#### EXAMPLE

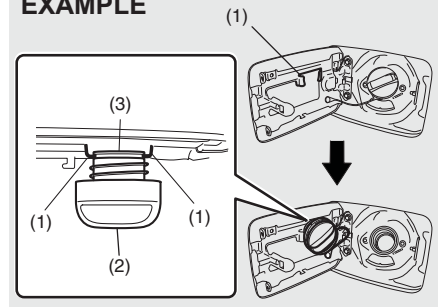

61MM0B104

#### NOTE:

The cap holder (1) holds the fuel filler cap (2) by hooking the cap to the groove (3) when refueling.

To reinstall the fuel filler cap:

- 1) Turn the cap clockwise until you hear several clicks.
- 2) Close the fuel filler lid.

#### WARNING

**Fuel is extremely flammable. Do not smoke when refueling, and make sure there are no open flames or sparks in the area.**

**⚠ WARNING**

If you need to replace the fuel filler cap, use a MARUTI genuine cap. Use of an improper cap can result in a malfunction of the fuel system or emission control system. It may also result in fuel leakage in the event of an accident.

**Engine Hood**

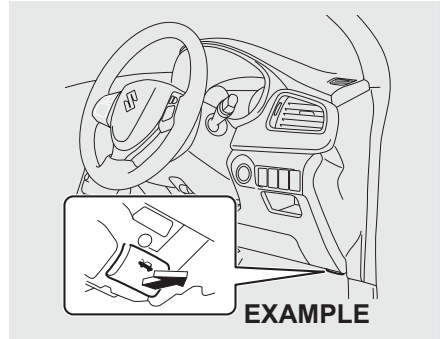

To open the engine hood:

- 1) Pull the hood release handle located on the outboard side of the driver's side of the instrument panel. This will disengage the engine hood lock halfway.

**EXAMPLE**

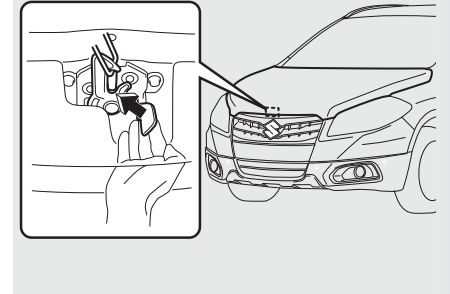

- 2) Pull the under-hood release lever sideways with your finger, as shown in the illustration. While pulling the lever, lift up the engine hood.

**⚠ CAUTION**

The release lever can be hot enough to burn your finger right after driving. Touch the lever after it becomes cool enough.

**NOTICE**

Make sure that the wiper arms are not raised before you lift up the engine hood to avoid damaging the wiper arms and the engine hood.

## OTHER CONTROLS AND EQUIPMENT

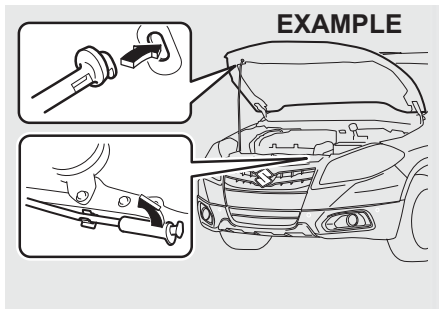

64MS127

- 3) While holding the hood, pull the prop rod out from the holding clip, then insert the end of the rod into the designated hole in the hood.

### ⚠ CAUTION

- The prop rod can be hot enough to burn your finger right after driving. Touch the rod after it becomes cool enough.
- Insert the end of the rod into the hole securely. If the rod drops off, your body may be caught in the hood.
- The rod may drop off when the hood is hit by a wind. Be careful on windy days.

To close the engine hood:

- 1) Lift the hood up slightly and remove the prop rod from the hole. Put the prop rod back to the holding clip.

### EXAMPLE

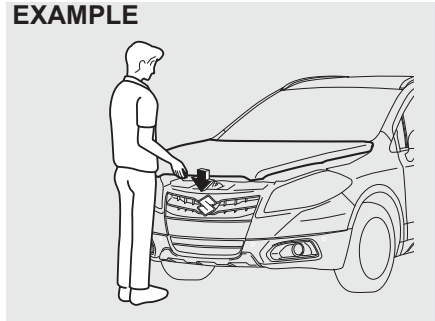

64MS128

- 2) Lower the hood to about 20 cm above the hood latch, then let it drop down. Make sure the hood is securely latched after closing.

### ⚠ WARNING

Make sure the hood is fully closed and latched before driving. If it is not, it can fly up unexpectedly during driving, obstructing your view and resulting in an accident.

### ⚠ CAUTION

To avoid injury, be sure no part of the occupant's body such as hands or head is in the path of the hood when closing it.

### NOTICE

Pressing the hood from above may damage the hood.

## Sun Visor

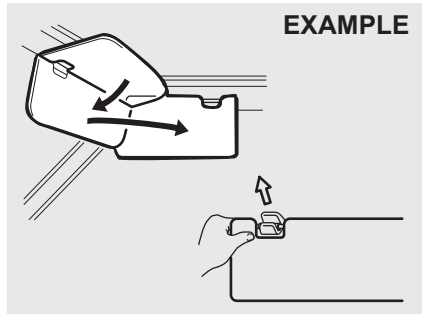

77PH004

The sun visors can be pulled down to block glare coming through the windshield, or they can be unhooked and turned to the side to block glare coming through the side window.

### NOTICE

When unhooking and hooking a sun visor, be sure to handle it by the hard plastic part or the sun visor may get damaged.

## Card holder (if equipped)

### Type A

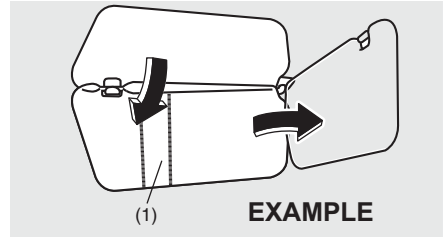

67LH064

### Type B

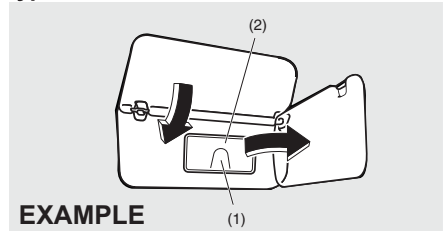

64MS172

- (1) Card holder
- (2) Mirror cover

You can put a card in the card holder (1) on the back of the sun visor.

### NOTICE

When you park your vehicle outdoors in direct sunlight or in hot weather, do not leave plastic cards in the holder. The heat may distort them.

## Vanity mirror (if equipped)

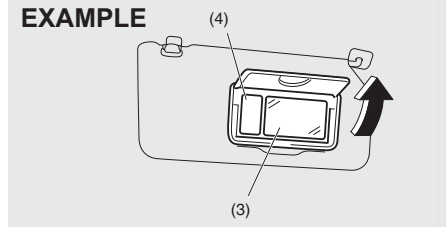

64MS076

- (3) Vanity mirror
- (4) Vanity mirror light (if equipped)

To use the vanity mirror (3) on the back of the sun visor, pull up the mirror cover (1).

The vanity mirror light (4) comes on when the mirror cover (1) is opened.

### ⚠ WARNING

- Do not use the mirror while driving your vehicle or you could lose control of the vehicle.
- When using the vanity mirror, do not move too close to a front air bag location or lean against it. If the front air bag is accidentally inflated, it could hit you hard.

### NOTICE

If the vanity mirror has the light, do not leave the mirror cover open for a long time, or the battery will discharge.

## OTHER CONTROLS AND EQUIPMENT

### Interior Light

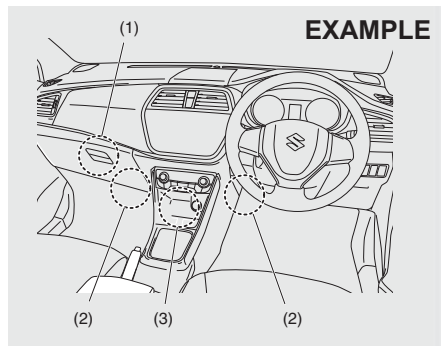

64MS118

- (1) Glove box light (if equipped)
- (2) Footwell lights (if equipped)
- (3) Instrument panel pocket light (if equipped)

### EXAMPLE

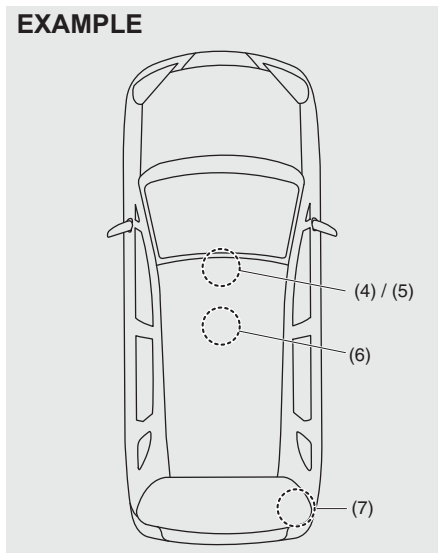

64MS078

- (4) Front (without overhead console)
- (5) Front (with overhead console)
- (6) Center
- (7) Luggage compartment (if equipped)

### Glove Box Light (if equipped) (1)

Refer to "Glove Box" in this section.

### Footwell Lights (if equipped) (2)

A footwell light is provided in the leg space in front of each front seat. When any door (including the tailgate) is open, the footwell lights on both sides light automatically.

#### NOTE:

*You can change the footwell lights operation via the information display. Refer to "Information Display" in the "BEFORE DRIVING" section.*

### Instrument Panel Pocket Light (if equipped) (3)

This light comes on while the position lights, tail light and/or the headlights are on.



**Front (without overhead console) (4)**

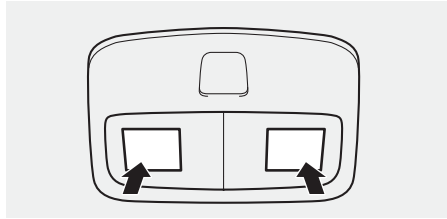

61MM0A205

Push the switch to turn on the light and push it again to turn off the light.

**Front (with overhead console) (5)**

**EXAMPLE**

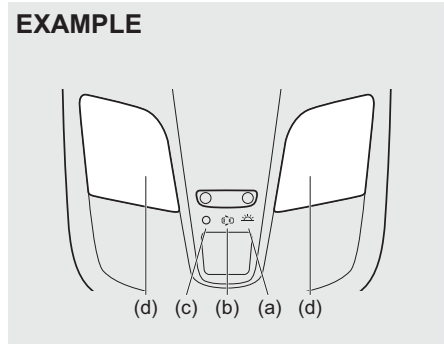

64MS119

**Center (6)**

**EXAMPLE**

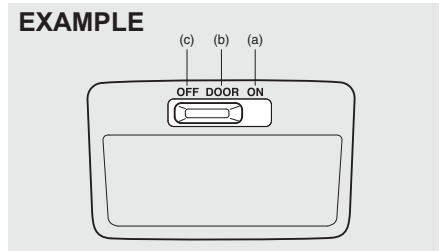

61MM0A107

These light switches have three or four positions with function as described below:

**ON (a)**

- The light comes on and stays on regardless of whether the door is open or closed.
- To save the battery, the light will be automatically turned off when a period of 15 minutes has elapsed after the light is on.

**DOOR (b)**

- The light comes on when the door is opened. After closing all doors, the light will remain on for about 15 seconds and then fade out. If you insert the key, or press the engine switch to change the ignition mode to ACC or ON during this time, the light will start to fade out immediately. After removing the key from the ignition switch, the light will turn on for about 15 seconds and then fade out.
- Regardless of whether the door is open or closed, the light comes on 15 seconds and then fade out when the ignition mode is changed to LOCK (OFF) or the ignition switch is turned to the "LOCK" position.

**OFF (c)**

The light remains off even when the door is opened.

**SPOT LIGHT (d)**

When the light switch is in the DOOR or OFF position, push the switch to turn on the light and push it again to turn off the light.

## OTHER CONTROLS AND EQUIPMENT

### Luggage Compartment (if equipped) (7)

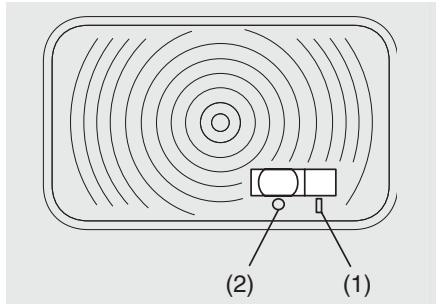

61MM0B023

When you open the tailgate with the luggage compartment light switch in the ON position (1), the light comes on and remains on as long as you keep the tailgate open.

When the luggage compartment light switch is in the OFF position (2), the light remains off regardless of whether the tailgate is open or close.

#### **NOTICE**

**Do not leave the tailgate open with the luggage compartment light switch in the ON position for a long time, or the battery will discharge.**

### EXAMPLE

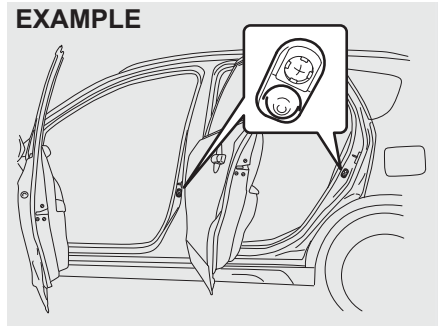

61MM0A108

#### **NOTE:**

*The number of doors involved in the lighting operation of the interior light depends on the vehicle specification. If there is a switch (rubber projection) at the door opening as shown, the door is involved in the lighting operation. The tailgate is also involved in this operation even without the rubber projection.*

### Accessory Socket Center console

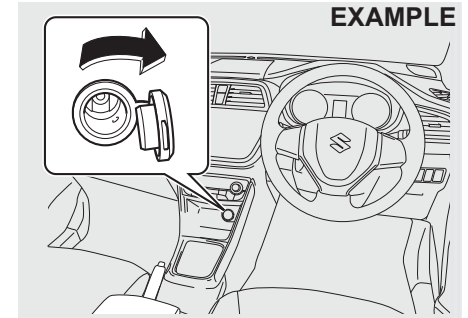

64MS080

### Luggage compartment (if equipped)

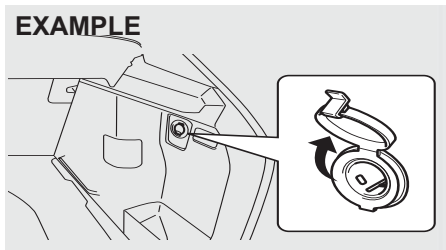

64MS147

The accessory socket will work when the ignition switch is in the “ACC” or “ON” position, or the ignition mode is “ACC” or “ON”. Each socket can be used to provide 12 volt/120 watt/10 ampere power for electrical accessories when used alone. Make sure that the cap remains on the socket when the socket is not in use.

#### NOTICE

- To prevent the fuse from being blown, when using sockets at the same time, do not exceed the total combined power capacity of 12 volt/120 watt/10 ampere.
- Use of inappropriate electrical accessories can cause damage to your vehicle’s electrical system. Make sure that any electrical accessories you use are designed to plug into this type of socket.

### Assist Grips (if equipped)

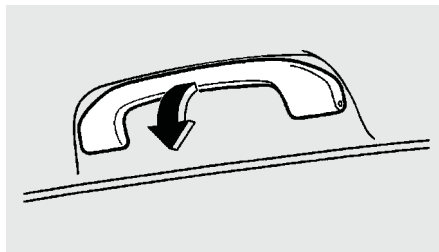

54G249

Assist grips are provided for convenience.

#### NOTICE

To avoid damaging the assist grip and the molded headlining, do not hang down on the assist grip.

### Coat Hooks (if equipped)

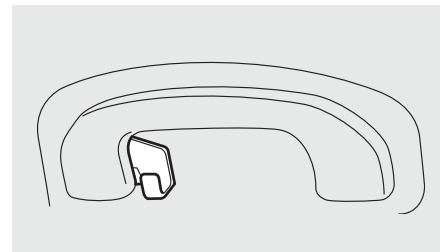

61MM0B025

You can hang clothing on the coat hooks. These hooks are not designed for large or heavy items.

#### ⚠ WARNING

If your vehicle is equipped with side curtain air bags, do not hang sharp items like a hanger on the coat hook. When hanging the clothes, hang them on the hook without using a hanger.

## OTHER CONTROLS AND EQUIPMENT

### Glove Box

EXAMPLE

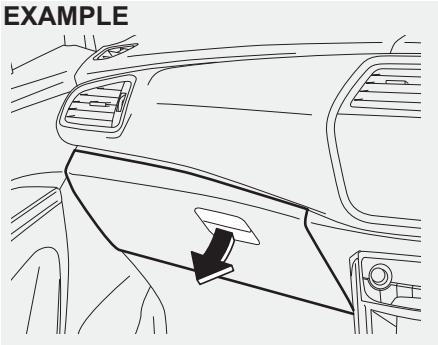

64MS120

To open the glove box, pull the latch lever. To close it, push the lid until it latches securely.

#### **WARNING**

Never drive with the glove box lid open. It could cause injury if an accident occurs.

EXAMPLE

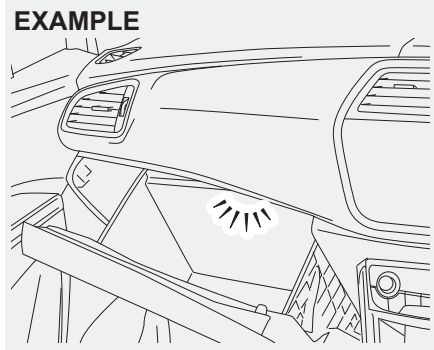

64MS148

The glove box light (if equipped) stays on while the lid is open.

### Overhead Console (if equipped)

EXAMPLE

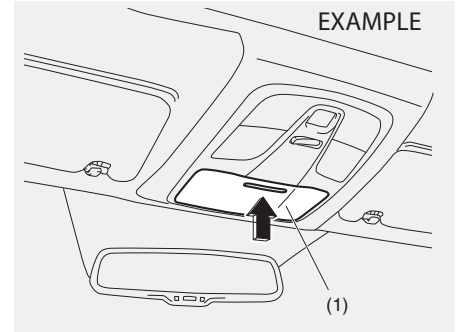

64MS121

Use this stowage to keep small articles. You can open the lid (1) by pressing the raised portion on it.

### **WARNING**

- Do not drive with the overhead console lid open, or the articles stowed inside could fall down during braking, acceleration or in the event of a collision. Always close the lid after putting something into or taking something out of the console.
- If you park your vehicle outdoors in direct sunlight or in hot weather, the overhead console can get very hot since it is close to the roof. So, when parking in such conditions:
  - Do not leave eyeglasses in the overhead console. The heat may distort plastic lenses or frames.
  - Do not place flammable items, such as a lighter, in the overhead console. The heat may cause a fire.

### ***NOTICE***

- Do not apply undue force to the lid when closing it. Doing so could break the lid and articles inside.
- Place glasses in a case when stowing them in the overhead console, or the lenses may be damaged.

## OTHER CONTROLS AND EQUIPMENT

### Cup Holder and Storage Area

#### EXAMPLE

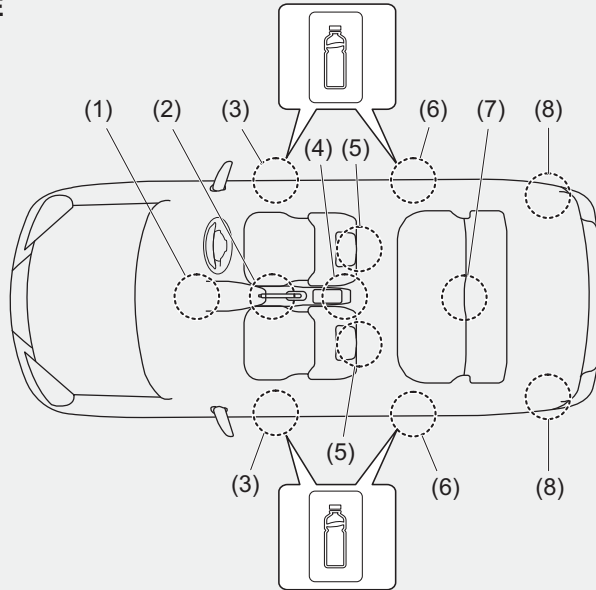

64MS081

- |   |  |
|---|--|
| (1) Instrument panel pocket                     | (2) Front cup holders                            |
| (3) Front bottle holder                         | (4) Front armrest with console box (if equipped) |
| (5) Front seat back pocket                      | (6) Rear bottle holder                           |
| (7) Rear armrest with cup holders (if equipped) | (8) Luggage compartment pocket                   |

### Instrument Panel Pocket (1)

#### ⚠ WARNING

Do not place any objects which may fall out from the pocket when the vehicle is moving. Failure to take the precaution may result in an object interfering with the pedals and causing a loss of vehicle control or an accident.

### Front Cup Holders (2)

#### ⚠ WARNING

Failure to take the precautions listed below could cause personal injury or vehicle damage.

- Be careful when you are using the cup holders to hold a cup containing hot liquid. Spilling out hot liquid can cause burn injury.
- Do not use the cup holders to hold sharp-edged, hard, or breakable objects. Objects in the cup holders may be thrown about during a sudden stop or impact, and could cause personal injury.
- Be careful not to spill liquid or insert any foreign materials into the moving part of the gearshift lever, or any electrical components. Liquid or foreign materials may damage these parts.

**Front Bottle Holder (3) /  
Rear Bottle Holder (6)**

You should hold a bottle with a cap in the holder.

**Front Armrest with Console Box  
(if equipped) (4)**

**NOTICE**

To avoid damage to the armrest, do not lean on it or allow a child to sit on it.

**EXAMPLE**

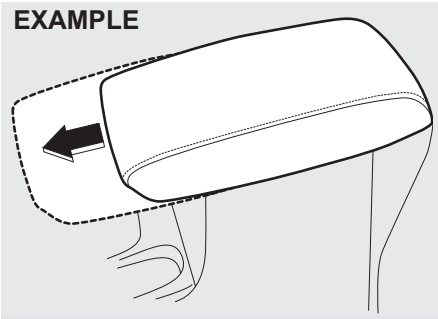

61MM0B029

The armrest can be slid forward.

**Console box**

Use this stowage for keeping small items. Open the compartment by raising the top lid while keeping the lever (1) up.

**EXAMPLE**

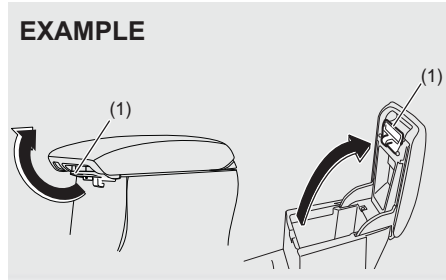

61MM0B030

**NOTE:**

Always close the lid after you put something into or take something out of the box.

**AUX/USB socket (if equipped)**

**EXAMPLE**

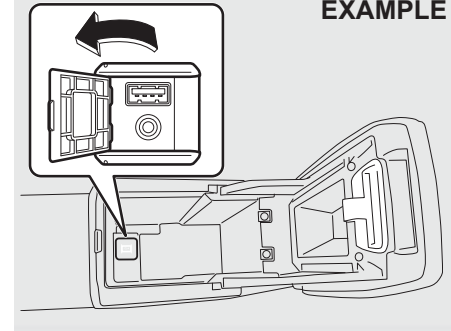

64MS082

The AUX/USB socket is provided in the console box. Connect your portable digital music player, etc. to this socket to enjoy music through the vehicle's audio system using it as a source. Refer to "Audio System" in this section.

**NOTICE**

Do not place any objects in console box which may spill water or liquid. Spilling of liquid on AUX/USB socket can cause damage malfunction of AUX/USB socket.

## OTHER CONTROLS AND EQUIPMENT

### Front Seat Back Pocket (5)

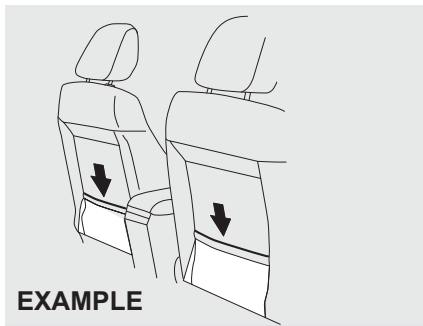

64MS083

This pocket is provided for holding light and soft things such as gloves, newspapers or magazines.

#### **⚠ CAUTION**

Do not put hard or breakable objects in the pocket. If an accident occurs, objects such as bottles, cans, etc. can injure the occupants in the rear seat.

### Rear Armrest with Cup Holders (if equipped) (7)

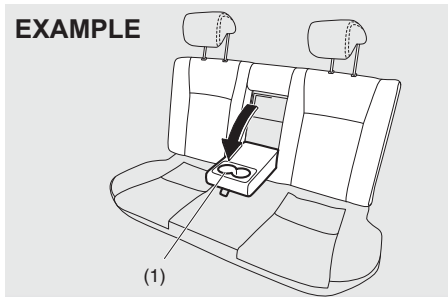

64MS158

(1) Cup holders

The rear armrest is stowed in the center of the seatback. Tilt it down forward to use.

#### **⚠ WARNING**

- If the seat belt is obstructed by any part of the armrest when fastened, it cannot provide the intended protection. After fastening the seat belt, always check that the armrest is not interfering with the belt.
- In an accident or sudden stop, the rear seat armrest could fall forward. If there is a child in a rear-facing child restraint in the rear center seating position, the falling armrest could injure the child. Do not install a rear-facing child restraint in the rear center seating position.

### Luggage Compartment Pocket (8)

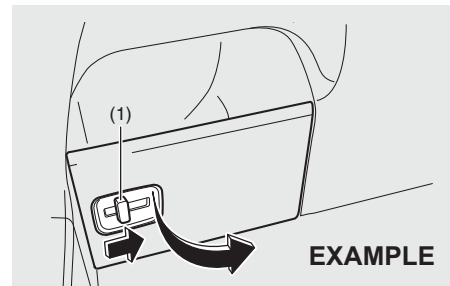

61MM0B034

To open the lid, slide the lever (1) and pull the lid.



## Footrest (if equipped)

### EXAMPLE

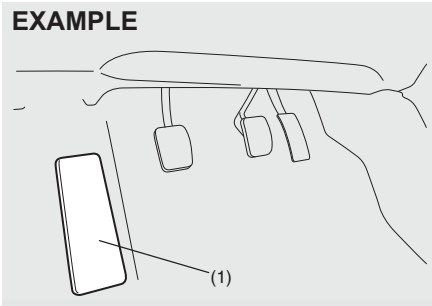

58MST0509

Use the footrest (1) as a support for your left foot.

## Floor Mats (if equipped)

### EXAMPLE

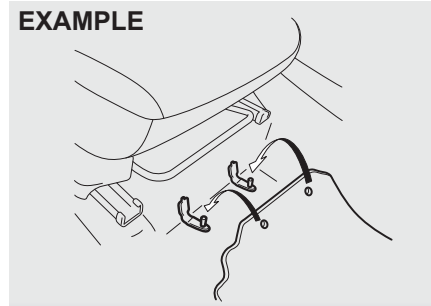

64MS085

To prevent the driver's side floor mat from sliding forward and possibly interfering with the operation of the pedals, MARUTI genuine floor mats are recommended. Whenever you put the driver's side floor mat back in the vehicle after it has been removed, be sure to hook the floor mat grommets to the fasteners and position the floor mat properly in the footwell.

When you replace the floor mats in your vehicle with a different type such as all-weather floor mats, we highly recommend using MARUTI genuine floor mats for proper fitting.

### ⚠ WARNING

Failure to take the following precautions may result in the driver's side floor mat interfering with the pedals and causing a loss of vehicle control or an accident.

- Make sure that the floor mat grommets are hooked to the fasteners.
- Never place additional floor mats on top of the existing floor mat.

## OTHER CONTROLS AND EQUIPMENT

### Luggage Compartment Hooks Shopping Hook

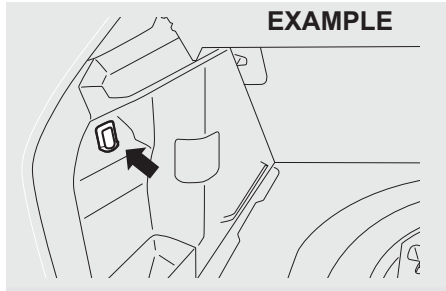

64MS086

You can hang the shopping bag or other suitable objects on the hook. This hook is not designed for large or heavy items.

#### **NOTICE**

To avoid breaking the hook, do not hang items heavier than following weight.  
Shopping hook: 2 kg (4.4 lbs)

### Luggage Compartment Cover (if equipped)

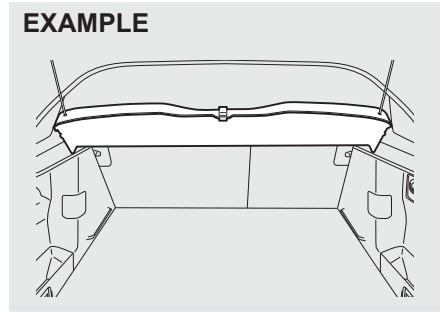

64MS087

Luggage or other cargo placed in the luggage compartment is hidden from view by a luggage compartment cover.

#### **⚠ WARNING**

Do not carry items on top of the luggage compartment cover, even if they are small and light. Objects on top of the cover could be thrown about in an accident, causing injury, or could obstruct the driver's rear view.

### Luggage Compartment Board

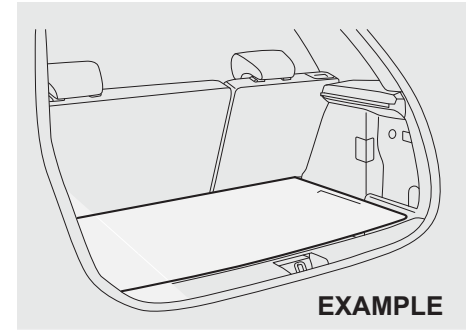

64MS088

Your vehicle is equipped with the luggage compartment board in the luggage compartment. You can place luggage or other cargos on the board or under the board. You can also place tall luggage by removing the board from the luggage compartment.

#### **⚠ WARNING**

Objects that extend higher than the luggage compartment cover (if equipped) can obstruct the driver's rear view, which can cause an accident. These objects can also become damaged or can damage the tailgate.

Do not carry items that extend higher than the luggage compartment cover.

**⚠ CAUTION**

If you are not careful when handling the luggage board, you could be injured.

Handle the luggage board carefully when removing or installing it.

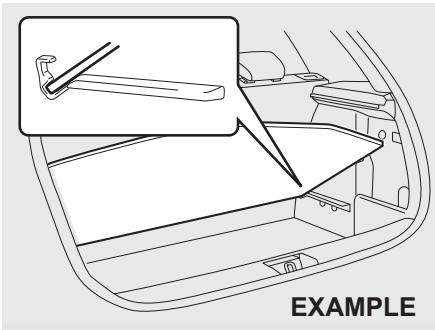

61MM0B036

The luggage compartment board can be held open as shown in the illustration.

**NOTICE**

Do not apply undue force to the board which is held open, and do not hold open the board while driving. Doing so could break the board or the interior.

**Roof Rails or Roof Rack Anchors (if equipped)**

**Roof rails**

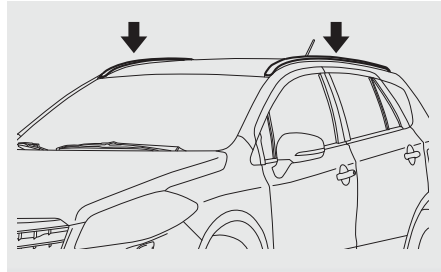

64MS139

**Roof rack anchors**

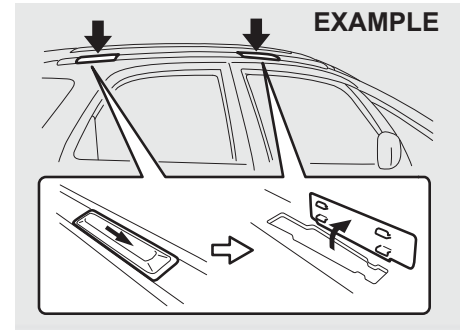

80J082

You can use the roof rails or the roof rack anchors to attach the optional roof rack which is available at your MARUTI SUZUKI NEXA dealer / authorised Maruti Suzuki workshop. If you use a roof rack, observe the instructions and precautions in this section and provided with the roof rack.

- Make sure the roof rack is securely installed.
- Do not mount cargo directly on the roof panel. The cargo can damage the roof panel.
- The gross weight of the roof rack plus cargo must not exceed the loading capacity.

- Roof rails: 40 kg (88 lbs)
- Roof rack anchors: 40 kg (88 lbs)

Also, do not let the gross vehicle weight (fully loaded vehicle including driver, passengers, cargo, roof load and trailer

## OTHER CONTROLS AND EQUIPMENT

tongue weight) exceed the Gross Vehicle Weight Rating (GVWR) listed in the “**SPECIFICATIONS**” section of this manual.

- Mount and secure the cargo onto the roof rack properly according to the instructions provided. Be sure to stow the heaviest items at the bottom and distribute the cargo as evenly as possible.
- Do not carry items so large that they hang over the bumpers or the sides of the vehicle, or block your view.
- Secure the front and rear ends of long items – such as wood panels, surfboards and so forth – to both the front and rear of the vehicle. You should protect the painted surfaces of the vehicle from scuffing caused by tie-down ropes.
- Check periodically to make sure the roof rack is securely installed and free from damage.
- For vehicles with roof rack anchors, make sure the anchors are covered with the caps when not in use.

### **WARNING**

- **Abrupt maneuvers or failure to properly secure cargo can allow the cargo to fly off the vehicle and hit others, causing personal injury or property damage.**
- **Mount cargo securely and avoid abrupt maneuvers such as jackrabbit starts, sharp turns, fast cornering and sudden braking. Check periodically to make sure that cargo is securely fastened.**
- **Large, bulky, long, or flat items can affect vehicle aerodynamics or be caught by the wind, and can reduce vehicle control resulting in an accident and personal injury. Drive cautiously at a safely reduced speed when carrying this type of cargo.**

## Frame Hooks

MARUTI SUZUKI does not recommend you use the frame hooks for towing another vehicle. Your vehicle was originally designed to be towed on the road in case of emergency towing. If your vehicle needs to be towed in an emergency, refer to “Towing” in “**EMERGENCY SERVICE**” section.

### **WARNING**

**Observe the following instructions when using frame hooks. The towing hook or vehicle body may break and cause serious injury or damage.**

- **Do not use the frame hooks for towing another vehicle.**
- **Avoid pulling the vehicle to get out of severe snowy, muddy or sandy conditions, sudden starts or erratic driving maneuvers which could cause excessive stress on the towing hook.**

**In such case, we recommend that you contact a professional service.**

Front

EXAMPLE

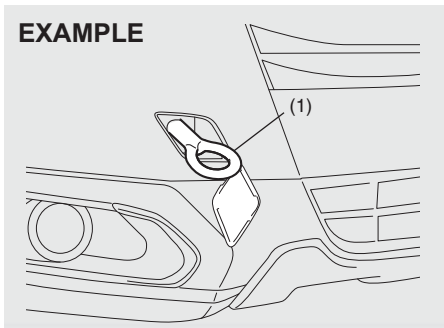

61MM0B038

The towing hook (1) is provided on the front of the vehicle for use in emergency situations only.

To install the hook (1), follow the procedure below.

EXAMPLE

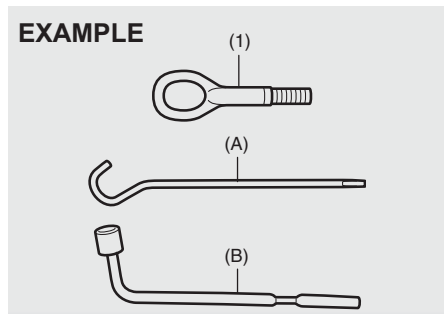

61MM0B039

- 1) Pick up the towing hook (1), jack handle (A) and wheel brace (B) stowed in the luggage compartment.

EXAMPLE

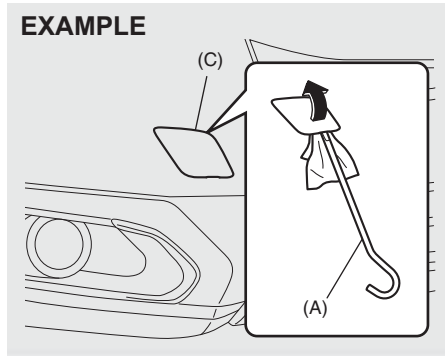

61MM0B040

- 2) Remove the cover on bumper (C) by using a jack handle (A) covered with a soft cloth as shown in the illustration.

**NOTE:**  
Do not use excessive force as it may damage the cover strap.

EXAMPLE

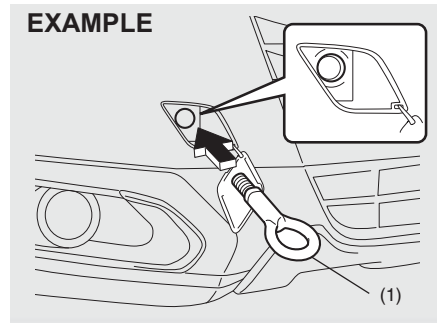

61MM0B041

- 3) Install the towing hook (1) by hand.

**NOTE:**  
We recommend to fasten the cover with tape to prevent damage during towing.

EXAMPLE

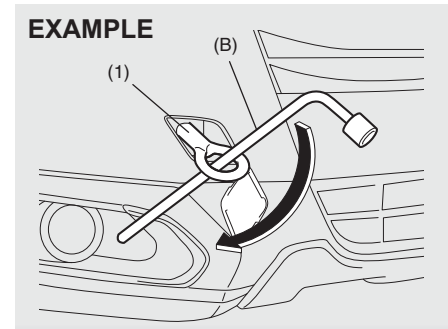

61MM0B042

## OTHER CONTROLS AND EQUIPMENT

- 4) To tighten the towing hook (1), turn it clockwise by using a wheel brace (B) until the hook (1) is securely installed.

To remove the towing hook (1), reverse the procedure used to install the towing hook.

### Rear

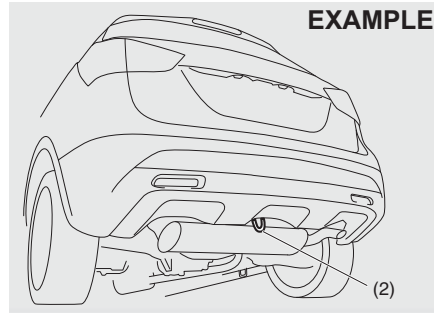

64MS140

The frame hook (2) is provided on the rear of the vehicle for use in emergency situations and sea shipping purposes only.

### Other Hooks

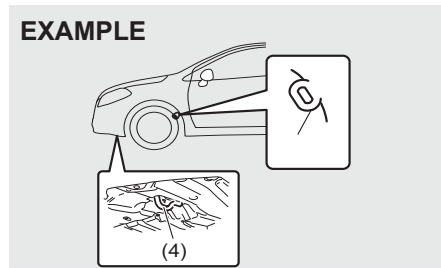

64MS174

The hooks (3) are provided for trailer/train shipping purposes only. The hooks (4) are provided for sea shipping purpose only.

### ⚠ WARNING

Do not use the hooks (3) and (4) for towing purpose. These hooks may break and cause serious injury or damage.

### NOTICE

To prevent damage to the vehicle, never use the towing hook (1) for trailer / train shipping and sea shipping purposes.

## Air Conditioning System

There are two types of heating and air conditioning systems as follows:

- Manual Heating and Air Conditioning System
- Automatic Heating and Air Conditioning System (Climate Control) (if equipped)

## Air Outlet

### EXAMPLE

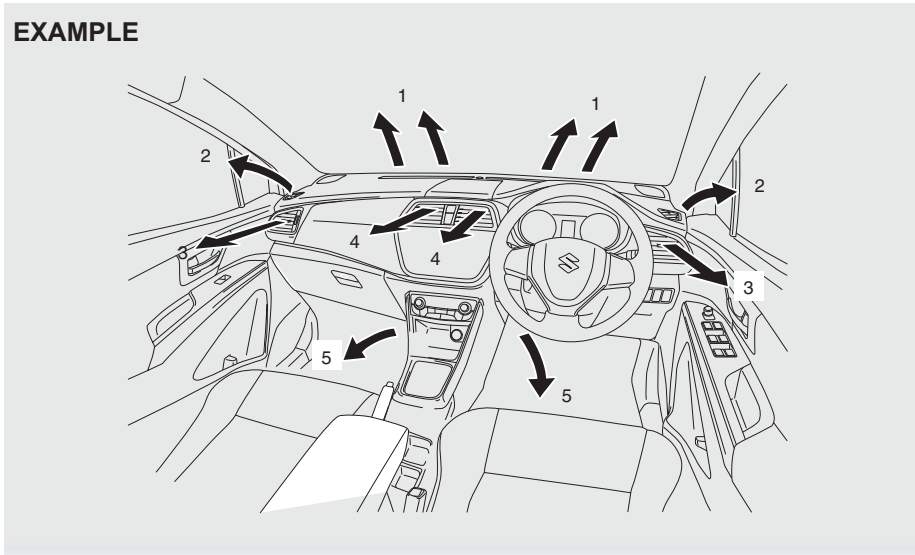

64MS159

1. Windshield defroster outlet
2. Side defroster outlet
3. Side outlet
4. Center outlet
5. Floor outlet

## Side outlet

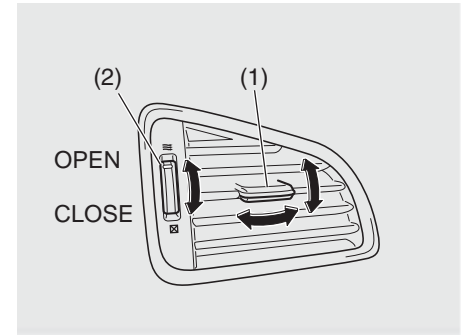

60M0014

Move the knob (1) vertically or horizontally, to adjust the direction of airflow as desired. Move the dial (2) to open or close the outlet.

## OTHER CONTROLS AND EQUIPMENT

### Center outlet

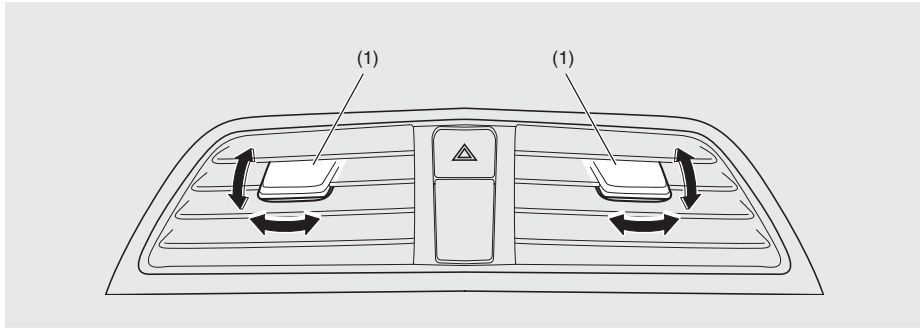

61MM0B047

Move the knob (1) vertically or horizontally to adjust the direction of airflow as desired.

## Manual Heating and Air Conditioning System

### Description of Controls

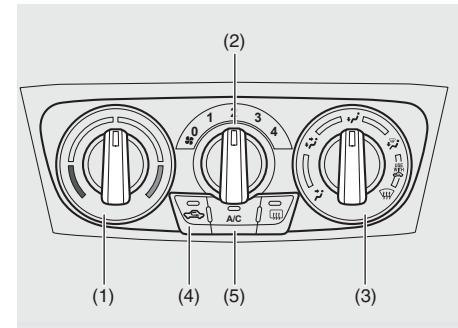

61MM0A018

#### Temperature selector (1)

This is used to select the temperature by turning the selector.

#### Blower speed selector (2)

This is used to turn on the blower and to select blower speed by turning the selector.



**Air flow selector (3)**

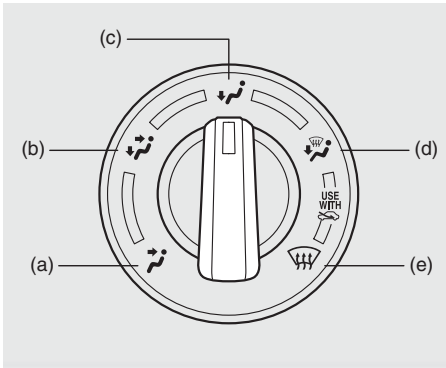

61MM0A019

This is used to select one of the functions described below.

**Ventilation (a)**

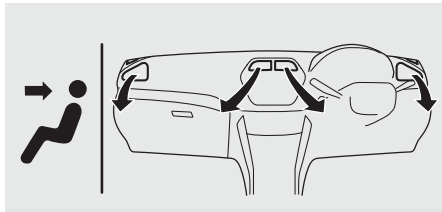

61M0100

Temperature-controlled air comes out of the center and side air outlets.

**Bi-level (b)**

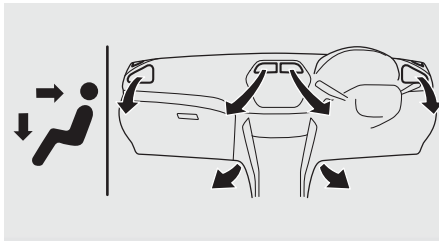

61M0101

Temperature-controlled air comes out of the floor outlets and cooler air comes out of the center and side outlets. When the temperature selector (1) is in the fully COLD position or fully HOT position, however, the air from the floor outlets and the air from the center and side outlets will be the same temperature.

**Heat (c)**

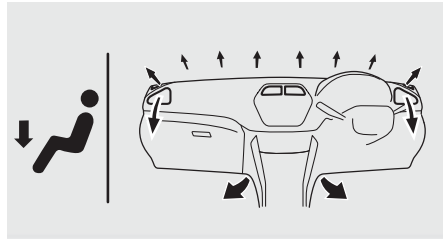

61M0102

Temperature-controlled air comes out of the floor outlets and the side outlets, also comes out of the windshield defroster out-

lets and also comes slightly out of the side defroster outlets.

**Heat & defrost (d)**

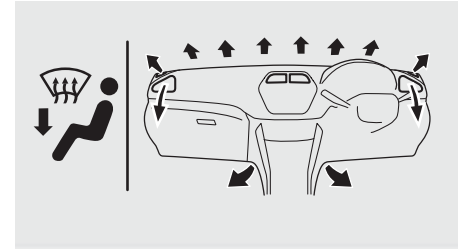

64MS036

Temperature-controlled air comes out of the floor outlets, the windshield defroster outlets, the side defroster outlets and the side outlets.

**Defrost (e)**

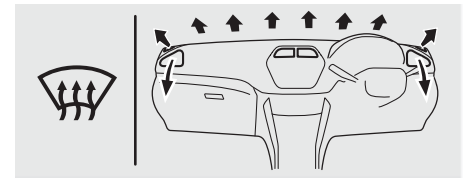

64MS090

Temperature-controlled air comes out of the windshield defroster outlets, the side defroster outlets and the side outlets.

## OTHER CONTROLS AND EQUIPMENT

### Air intake selector (4)

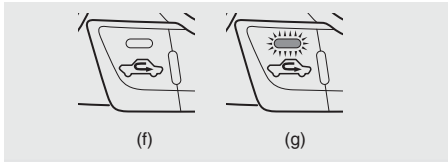

61MM0A020

This selector is used to select the following modes.

#### Fresh Air (f)

When this mode is selected, the indicator light will go off and outside air is circulated inside the cabin.

#### Recirculated Air (g)

When this mode is selected, the indicator light will come on, outside air is shut out and inside air is recirculated. This mode is suitable when driving through dusty or polluted air such as in a tunnel, or when attempting to quickly cool down the interior.

The "FRESH AIR" position (f) and RECIRCULATED AIR air position (g) are switched alternately each time the air intake selector is pushed.

#### NOTE:

*If you select the RECIRCULATED AIR position (g) for an extended period of time, the air in the vehicle can become contaminated. Therefore, you should occasionally select the "FRESH AIR" position (f).*

### Air conditioning switch (5)

To turn on the air conditioning system, set the blower speed selector to the desired blower speed position and push in the air conditioning switch (5). With the air conditioning switch operation, a indicator light will come on when the air conditioning system is on. To turn off the air conditioning system, push the air conditioning switch again.

During operation of the air conditioner, you may notice slight changes in engine speed. These changes are normal, the system is designed so that the compressor turns on or off to maintain the desired temperature.

Less operation of the compressor results in better fuel economy.

## System Operating Instructions

### Natural ventilation

Select the VENTILATION position (a) and "FRESH AIR" position (f), the temperature selector to the desired temperature position, and turn off the blower. Fresh air will flow through the vehicle during driving.

### Forced ventilation

The control settings are the same as for natural ventilation except turning the blower speed selector to turn on the blower.

### Normal heating (using outside air)

Select the HEAT position (c) and "FRESH AIR" position (f), the temperature selector to the desired temperature position and the blower speed selector to the desired blower speed position. Setting the blower speed selector to a higher blower speed position increases heating efficiency.

### Quick heating (using recirculated air)

The control settings are the same as for normal heating except selecting the RECIRCULATED AIR air position (g). If you use this heating method for an extended period of time, the air in the vehicle can become contaminated and the windows can become misty. Therefore, use this method only for quick heating and change to the normal heating method as soon as possible.

### Head cooled/Feet warmed heating

Select the BI-LEVEL position (b) and “FRESH AIR” position (f), the temperature selector to the desired temperature position, and the blower speed selector to the desired blower speed position. Unless the temperature selector is in the fully COLD position or fully HOT position, the air that comes out of the center and side outlets will be cooler than the air that comes out of the floor outlets.

### Normal cooling

Set the air flow selector to the VENTILATION position (a), the temperature selector to the desired temperature position and the blower speed selector to the desired blower speed position, and push in the air conditioning switch (5) to turn on the air conditioning system. Setting the blower speed selector to a higher blower speed position increases cooling efficiency.

You can switch the air intake selector to either the “FRESH AIR” position (f) or RECIRCULATED AIR position (g) as you desire. Choosing the RECIRCULATED AIR position (g) increases cooling efficiency.

### Quick cooling (using recirculated air)

The control settings are the same as for normal cooling except selecting the RECIRCULATED AIR position (g) and the highest blower speed.

#### NOTE:

- *If you select the recirculated air position (g) for an extended period of time, the air in the vehicle can become contaminated. Therefore, you should occasionally select the “FRESH AIR” position (f).*
- *If your vehicle has been left in the sun with the windows closed, it will cool faster if you open the windows briefly while you operate the air conditioner with the air intake selector at the “FRESH AIR” position (f) and the blower at high speed.*

### Dehumidifying

Set the air flow selector to a desired air flow selector position, the temperature selector to the desired temperature position and the blower speed selector to the desired blower speed position. Also select the “FRESH AIR” position (f) and push in the air conditioning switch (5) to turn on the air conditioning system.

#### NOTE:

*Because the air conditioner dehumidifies the air, turning it on will help keep the windows clear, even when blowing heated air using the DEFROST position (e) or HEAT & DEFROST position (d).*

### EXAMPLE

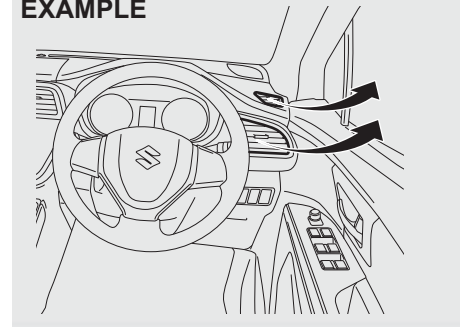

64MS091

#### NOTE:

*If you need maximum defrosting:*

- *select the DEFROST position (e) and “FRESH AIR” position (f),*
- *set the blower speed selector to HIGH,*

## OTHER CONTROLS AND EQUIPMENT

---

- *adjust the temperature selector to the HOT end,*
- *push in the air conditioning switch (5) to turn on the air conditioning system, and*
- *adjust the side outlets so the air blows on the side windows.*

### **Maintenance**

If you do not use the air conditioner for a long period, such as during winter, it may not give the best performance when you start using it again. To help maintain optimum performance and durability of your air conditioner, it needs to be run periodically. Operate the air conditioner at least once a month for one minute with the engine idling. This circulates the refrigerant and oil and helps protect the internal components.

If your air conditioner is equipped with air filters, clean or replace them as specified in the "Maintenance Schedule" in the **"INSPECTION AND MAINTENANCE"** section.

#### **NOTE:**

*Your vehicle uses the air conditioning refrigerant HFC-134a, commonly called "R-134a". R-134a replaced R-12 around 1993 for automotive applications. Other refrigerants are available, including recycled R-12, but only R-134a should be used in your vehicle.*

<b>NOTICE</b>
<b>Using the wrong refrigerant may damage your air conditioning system. Use R-134a only. Do not mix or replace the R-134a with other refrigerants.</b>

## Automatic Heating and Air Conditioning System (Climate Control) (If equipped)

### Description of Controls

#### EXAMPLE

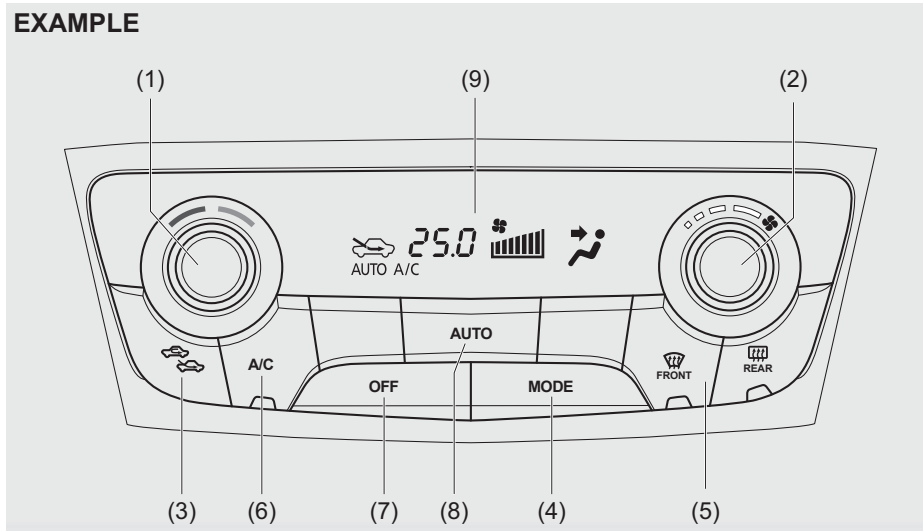

64MS050

### Temperature selector (1)

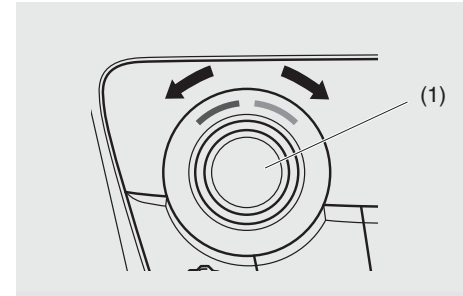

64MS051

Turn the temperature selector to adjust the temperature. The display (9) shows the selected temperature.

#### NOTE:

If you turn the temperature selector (1) until "HI" or "LO" appears on the display, the climate control system will operate at maximum heating or cooling. The temperature of the air from the outlets may change suddenly while "LO" or "HI" is displayed, but this is normal.

#### NOTE:

When you change the units of temperature in the information display, the automatic heating and air conditioning system temperature display units will be changed automatically. Refer to "Information Display" in the "BEFORE DRIVING" section for details.

- (1) Temperature selector
- (2) Blower speed selector
- (3) Air intake selector
- (4) "MODE" switch
- (5) Defrost switch
- (6) Air conditioning switch
- (7) "OFF" switch
- (8) "AUTO" switch
- (9) Display

## OTHER CONTROLS AND EQUIPMENT

### Blower speed selector (2)

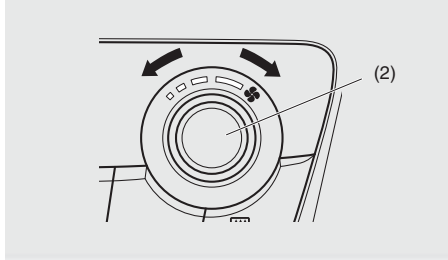

64MS052

The blower speed selector (2) is used to turn on the blower and to select blower speed.

If the “AUTO” switch (8) is pushed, the blower speed will vary automatically as the climate control system maintains the selected temperature.

### Air intake selector (3)

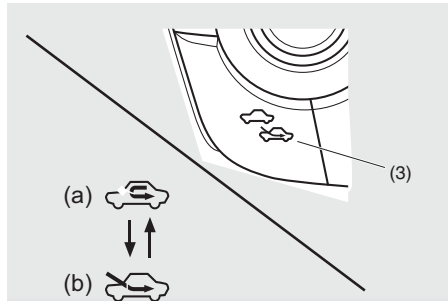

64MS053

Push the air intake selector (3) to change between the following modes.

If the “AUTO” switch (8) is pushed, the air intake will vary automatically as the climate control system maintains the selected temperature.

#### NOTE:

*When you select the recirculated air mode, the automatic operation system is deactivated if you push the “AUTO” switch (8).*

#### RECIRCULATED AIR (a)

When this mode is selected, outside air is shut off and inside air is recirculated. This mode is suitable when driving through an area with polluted air such as a tunnel, or when attempting to quickly cool down the vehicle.

#### FRESH AIR (b)

When this mode is selected, outside air is introduced.

The “FRESH AIR” position (b) and RECIRCULATED AIR position (a) are selected alternately each time the air intake selector is pushed.

#### NOTE:

*If you select the RECIRCULATED AIR position (a) for an extended period of time, the air in the vehicle can become contaminated. Therefore, you should occasionally select the “FRESH AIR” position (b).*

### “MODE” switch (4)

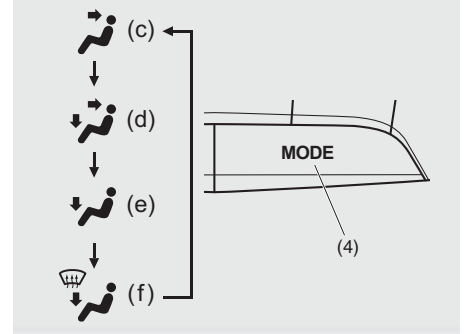

64MS054

Push the “MODE” switch (4) to change among the following functions. The indication of the selected mode appears on the display.

If the “AUTO” switch (8) is pushed, the air flow will vary automatically as the climate control system maintains the selected temperature.

### Ventilation (c)

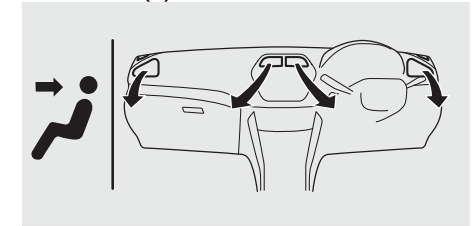

61M0100

Temperature-controlled air comes out of the center and side outlets.

**Bi-level (d)**

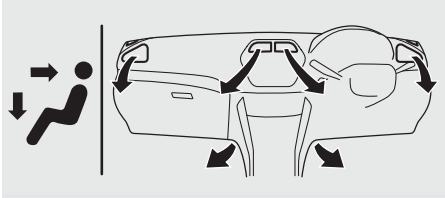

61M0101

Temperature-controlled air comes out of the floor, center and side outlets.

**Heat (e)**

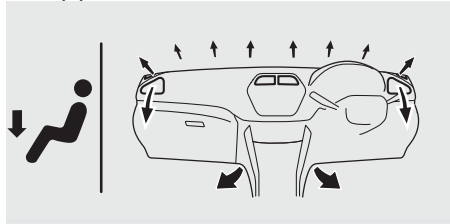

61M0102

Temperature-controlled air comes out of the floor outlets, also comes out of the windshield defroster outlets and also comes slightly out of the side defroster outlets and the side outlets.

**Heat & defrost (f)**

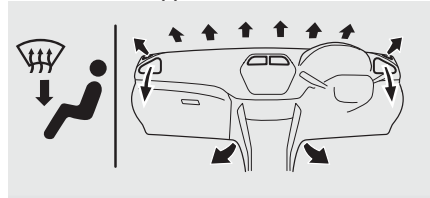

61M0103

Temperature-controlled air comes out of the floor outlets, the windshield defroster outlets, the side defroster outlets and the side outlets.

**Defrost switch (5)**

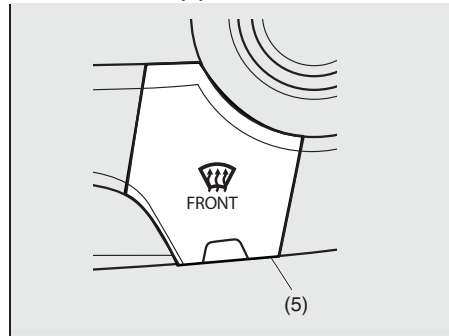

64MS038

Push the defrost switch (5) to turn on the defroster.

**Defrost**

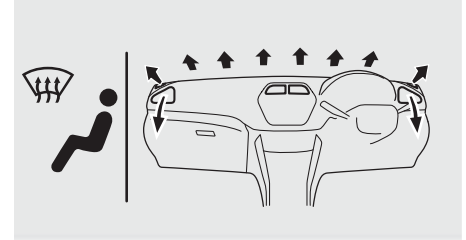

61M0106

Temperature-controlled air comes out of the windshield defroster outlets, the side defroster outlets and the side outlets.

**NOTE:**

When you push the defrost switch (5), the fresh air position (b) will be automatically selected and the air conditioning switch will automatically turn on ("A/C" will appear on the display). In cold weather, air flows out of the defroster outlets but the air conditioning does not turn on even though the A/C indicator comes on as well as the defrost indicator.

## OTHER CONTROLS AND EQUIPMENT

### Air conditioning switch (6)

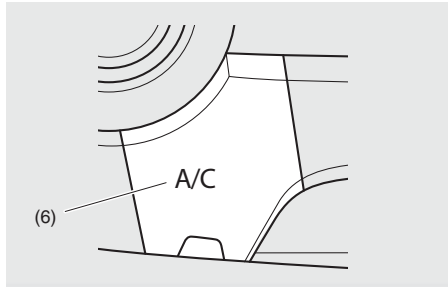

64MS055

The air conditioning switch (6) is used to turn on and off the air conditioning system only when the blower is on. To turn on the air conditioning system, push in the switch; "A/C" will appear on the display and the indicator on the switch will come on. To turn off the air conditioning system, push in the switch again; "A/C" and the indicator will go off.

You can use the air conditioning switch (6) to manually turn the air conditioner on or off according to your preference. When you turn the air conditioning switch off, the climate control system cannot lower the inside temperature below outside temperature.

### System Operating Instructions

#### Automatic operation

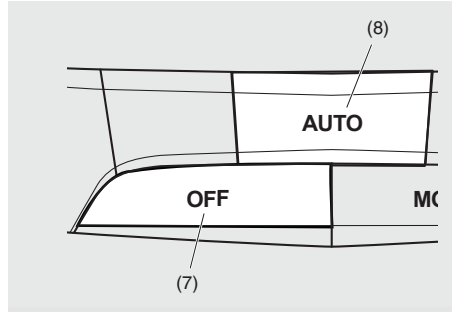

64MS056

You can let the climate control system work automatically. To set the system for fully-automatic operation, follow the procedure below.

- 1) Start the engine.
- 2) Push the "AUTO" switch (8).
- 3) Set the desired temperature by turning the temperature selector (1).

The blower speed, air intake and air flow are controlled automatically to maintain the set temperature. However, the air flow is not changed to the defrost position automatically.

To turn the climate control system off, push the "OFF" switch (7).

#### NOTE:

If the "AUTO" on the display blinks, there is a problem in the heating system and/or air conditioning system. You should have the system inspected by an authorised Maruti Suzuki workshop.

#### NOTE:

- To find the temperature at which you are most comfortable, start with the 25°C (75°F) setting, for example.
- If you turn the temperature selector (1) until "HI" or "LO" appears on the display, the climate control system will operate at maximum heating or cooling.
- To avoid blowing cold air in cold weather or hot air in hot weather, the system will delay turning on the blower until warmed or chilled air is available.
- If your vehicle has been left in the sun with the windows closed, it will cool faster if you open the windows briefly.
- Even under automatic operation, you can set individual selectors to the manual mode. The manually selected functions are maintained, and the other functions remain under automatic operation.
- If the windshield and/or the front door windows are fogged, push the defrost switch (5) to turn on the defroster, or push the "MODE" switch (4) to change the air flow to the heat & defrost position (f) to defog the windows.



- To return the blower speed selector (2), air intake selector (3), and “MODE” switch (4) to automatic operation, push the “AUTO” switch (8).

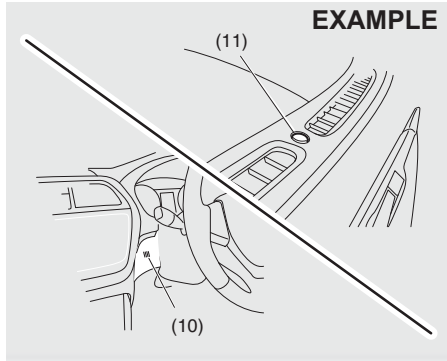

Be careful not to cover the interior temperature sensor (10) located between the steering wheel and the climate control panel, or the solar sensor (11) located at the top of the central part of the dashboard. These sensors are used by the automatic system to regulate temperature.

### Manual operation

You can manually control the climate control system. Set the selectors to the desired positions.

### EXAMPLE

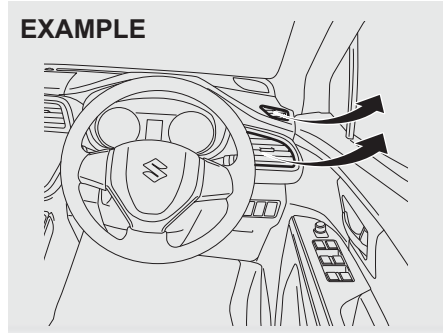

### NOTE:

If you need maximum defrosting:

- push the defrost switch (5) to turn on the defroster (the air conditioning system will come on and the fresh air position (b) will be selected automatically),
- set the blower speed selector to HIGH,
- adjust the temperature selector to the “HI” indication on the display, and
- adjust the side outlets so the air blows on the side windows.

### Maintenance

If you do not use the air conditioner for a long period, such as during winter, it may not give the best performance when you start using it again. To help maintain optimum performance and durability of your air conditioner, it needs to be run periodically. Operate the air conditioner at least once a month for one minute with the engine idling. This circulates the refrigerant and oil and helps protect the internal components.

If your air conditioner is equipped with air filters, clean or replace them as specified in the “Maintenance Schedule” in the “INSPECTION AND MAINTENANCE” section.

### NOTE:

Your vehicle uses the air conditioning refrigerant HFC-134a, commonly called “R-134a”. R-134a replaced R-12 around 1993 for automotive applications. Other refrigerants are available, including recycled R-12, but only R-134a should be used in your vehicle.

### NOTICE

Using the wrong refrigerant may damage your air conditioning system. Use R-134a only. Do not mix or replace the R-134a with other refrigerants.

### Radio Antenna

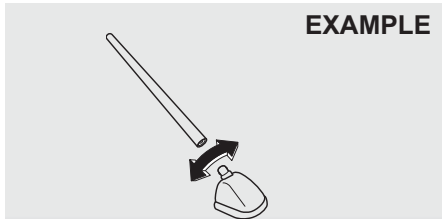

63J055

The radio antenna on the roof is removable. To remove the antenna, turn it counterclockwise. To reinstall the antenna, turn it clockwise firmly by hand.

#### **NOTICE**

To avoid damage to the radio antenna:

- Remove the antenna when using an automatic car wash.
- Remove the antenna when the antenna hits anything such as a low ceiling in a parking garage or putting a car cover over your vehicle.

### Installation of Radio Frequency Transmitters

We recommend that you always ask a authorised Maruti Suzuki workshop about frequency band, max output power, antenna position at vehicle and specific conditions for installation and/or use before installing a radio transmitter in your vehicle. Such equipments may cause the electronic control system to malfunction if they are incorrectly installed or they are not suited for the vehicle.

#### **NOTICE**

Improper installation of mobile communication equipment such as cellular telephones, CB (Citizen's Band) radios or any other wireless transmitters may cause electronic interference with your vehicle's ignition system, resulting in vehicle performance problems. Consult your authorised Maruti Suzuki workshop or qualified service technician for advice.

Audio System (if equipped)

EXAMPLE

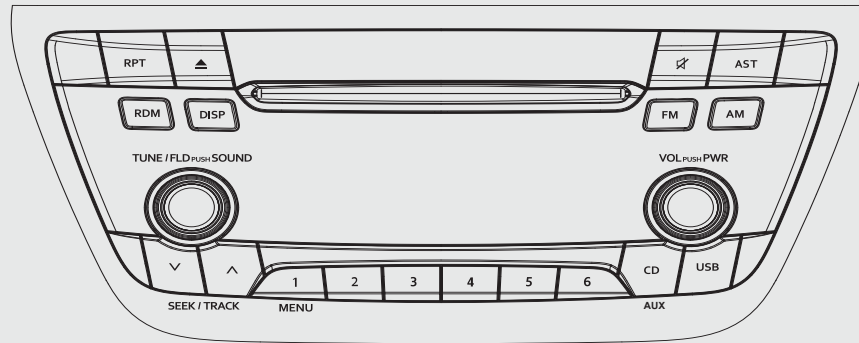

AM/FM CD PLAYER

64MS186

## OTHER CONTROLS AND EQUIPMENT

### Safety information

#### **WARNING**

If you pay extended attention to operating the audio system or viewing the audio system display while driving, an accident can occur. If you set the sound volume too loud, it could prevent you from being aware of road and traffic conditions.

- Keep your eyes on the road and your mind on the drive. Avoid paying extended attention to operating the audio system or viewing the audio system display.
- Familiarize yourself with the audio system controls and operation of the audio system before driving.
- Preset your favorite radio stations before driving so that you can quickly tune to them using the presets.
- Set the sound volume to a level that will allow you to continue to be aware of road and traffic conditions while driving.

### Notes on Discs

#### Precautions

- When the inside of the vehicle is very cold and the player is used soon after switching on the heater, condensation may form on the disc or the optical parts of the player and proper playback may not be possible. If condensation forms on the disc, wipe it off with a soft cloth. If condensation forms on the optical parts of the player, do not use the player for about one hour. This will allow the condensation to disappear normally.
- Driving on extremely bumpy roads which cause severe vibrations may cause track to skip.
- This unit uses a precision mechanism. Even in the event that trouble arises, never open the case, disassemble the unit, or lubricate the rotating parts. Please bring the unit to an authorized authorised Maruti Suzuki workshop.

### Cautions on Handling



This unit has been designed specifically for playback of compact discs bearing mark (A) shown above.

### No other discs can be play

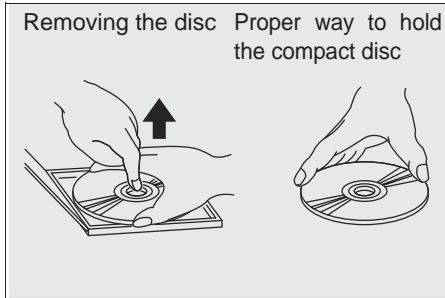

To remove the compact disc from its storage case, press down on the center of the case and lift the disc out, holding it carefully by the edges.

Always handle the compact disc by the edges.

Never touch the surface.

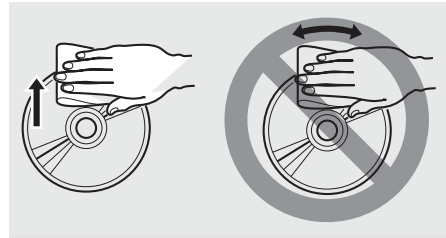

To remove fingermarks and dust, use a soft cloth, and wipe in a straight line from the center of the compact disc to the circumference.

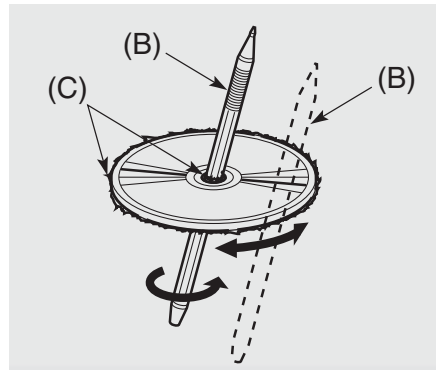

New discs may have some roughness around the edges. The unit may not work or the sound may skip if such discs are used. Use a ball-point pen (B), etc. to

remove the roughness (C) from the edges of the disc before inserting it into the unit.

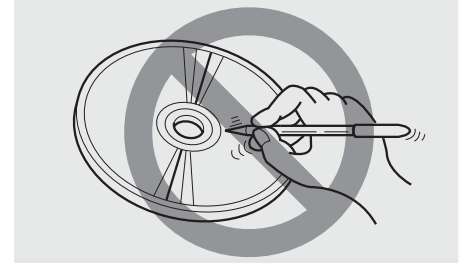

Never stick labels on the surface of the compact disc or write on the surface with a pencil or pen.



Do not use any solvents such as commercially available cleaners, anti-static spray, or thinner to clean compact discs.

## OTHER CONTROLS AND EQUIPMENT



Do not use compact discs that have large scratches, are misshaped, or cracked, etc. Use of such discs will cause damage or prevent the system from operating properly.

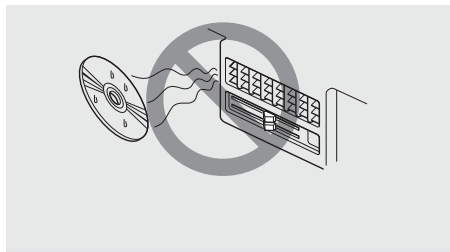

Do not expose compact discs to direct sunlight or any heat source.

### NOTE:

- Do not use commercially available CD protection sheets or discs equipped with stabilizers, etc. These may get caught in the internal mechanism and damage the disc.
- It may not be possible to play CD-R discs with this unit due to the recording conditions.
- CD-RW discs cannot be played with this unit.

### ⚠ WARNING

**This is a class I laser product. Use of controls or adjustments or performance of procedures other than those specified herein may result in hazardous radiation exposure.**

**Do not open covers and do not attempt to repair this unit by yourself. Refer a qualified personnel for servicing.**

### 📶 Bluetooth® (If equipped)

The Bluetooth® word mark and logo are registered trademarks and are owned by the Bluetooth SIG, Inc.

### Stop using this unit and a Bluetooth® ready device whenever requested.

This unit shares the communication frequency with other private or public wireless communication equipment such as a wireless LAN and other wireless communication radios.

You should stop using this unit whenever you are notified that your unit disturbs other wireless communication immediately.

### Bluetooth® Mic (1) (if equipped)

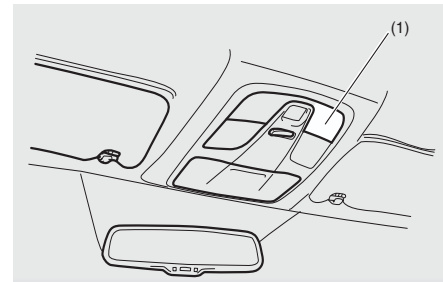

### Basic Operations

#### EXAMPLE

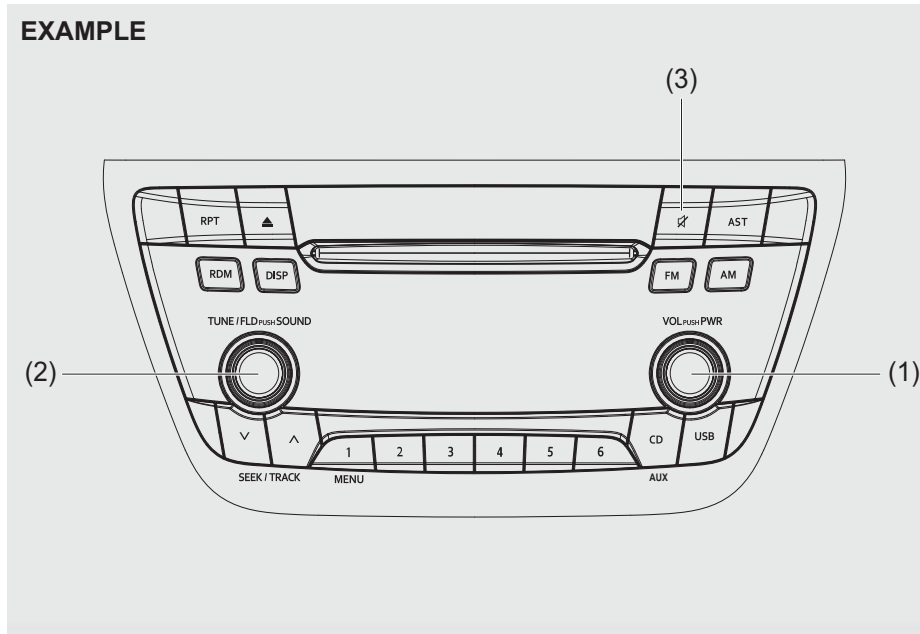

#### Turning power on/off

Press the VOL PUSH POWER knob (1).  
The unit starts in the function mode it was in when the power was turned off last.

#### Adjusting the volume

Turn the VOL PUSH POWER knob (1).  
Turning it clockwise increases the volume;  
turning it counterclockwise decreases the volume.

#### NOTE:

*While driving, adjust the volume to an extent that sound and/or noise coming from outside the vehicle can be heard.*

64MS187

- (1) VOL PUSH POWER knob
- (2) TUNE FOLDER PUSH SOUND knob
- (3) MUTE button

## OTHER CONTROLS AND EQUIPMENT

### Mute

Press the MUTE button (3) to mute the sound. To cancel the mute, press the MUTE button (3) again.

### Adjusting bass/treble/balance /fader

1) Press the TUNE FOLDER PUSH SOUND knob (2).

Each time the knob is pressed, sound adjustment will change as follows:

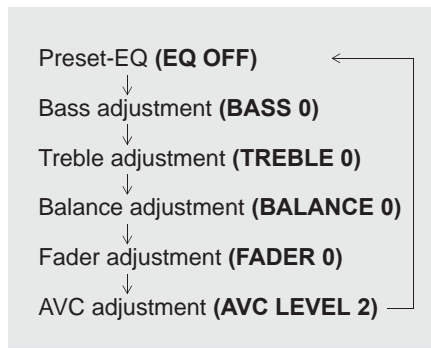

2) Turn the TUNE FOLDER PUSH SOUND knob (2) to adjust the sound.

### Adjusting the AVC (Auto volume control)

The Auto Volume Control (AVC) function automatically adjusts (increases/decreases) the sound volume in accordance with vehicle speed. The AVC control is provided with three selectable levels (LEVEL OFF, 1, 2, 3). The range of volume adjustment increases together with the LEVEL number.

1) Press the TUNE FOLDER PUSH SOUND knob (2) until the AVC adjustment mode is selected.

2) Turn the TUNE FOLDER PUSH SOUND knob (2) to select the desired AVC adjustment level. (Initial setting: LEVEL 2)

### Preset-EQ

Preset-EQ calls up various sound types in accordance with the listening music type.

1) Press the TUNE FOLDER PUSH SOUND knob (2) several times until "PRESET-EQ" appears.

2) Turn the TUNE FOLDER PUSH SOUND knob (2).

Each time the knob is turned, preset EQ mode will change as follows:

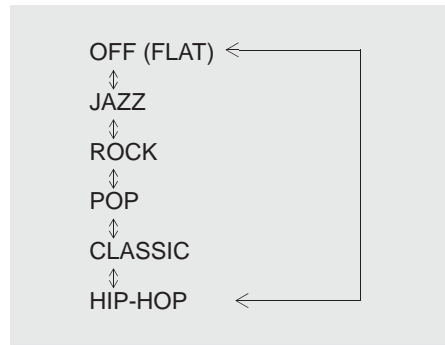



Listening to the Radio

EXAMPLE

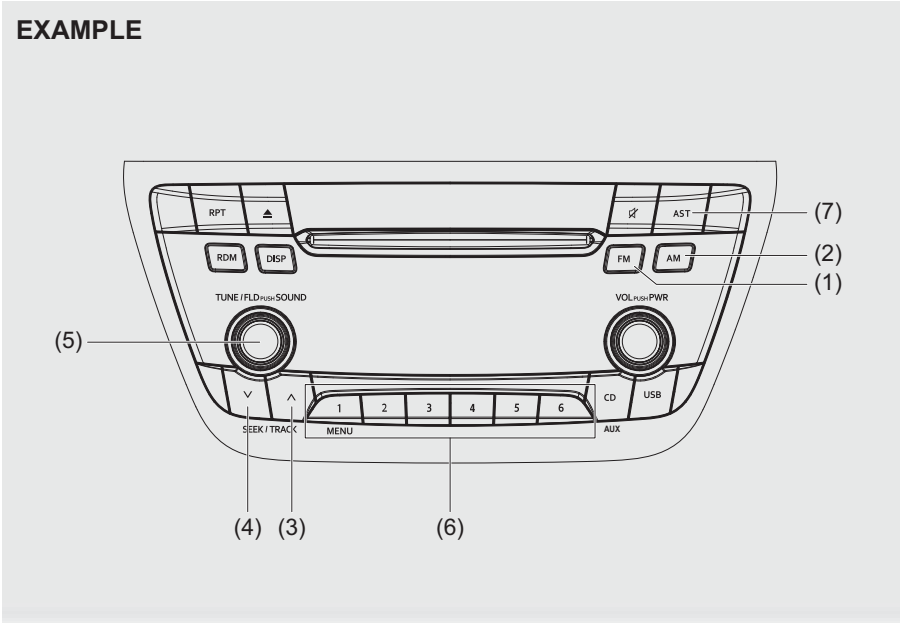

64MS188

Display

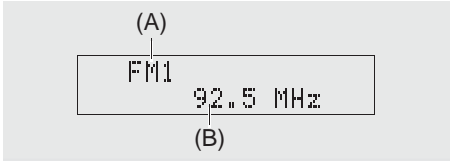

- (1) FM button
- (2) AM button
- (3) Up button
- (4) Down button
- (5) TUNE FOLDER PUSH SOUND knob
- (6) Preset buttons ([1] to [6])
- (7) AST button
  
- (A) Band
- (B) Frequency

## OTHER CONTROLS AND EQUIPMENT

### Selecting the FM band

Press the FM button (1).

Each time the button is pressed, the reception band will change as follows:

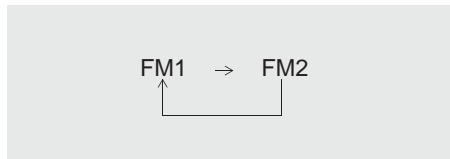

### Selecting the AM band

Press the AM button (2).

### Seek tuning

Press the seek Up button (3) or the seek Down button (4).

The unit stops searching for a station at a frequency where a broadcast station is available.

### Manual tuning

Turn the TUNE FOLDER PUSH SOUND knob (5).

The frequency being received is displayed

### Preset memory

- 1) Select the desired station.
- 2) Hold down a desired button ([1] to [6]) of the Preset buttons (6) to which you want to store the station for 2 seconds or longer.

### Auto store

Hold down the AST button (7) for 2 seconds or longer.

Six stations in good reception will automatically be stored to the Preset buttons (6) in order, starting from a station whose frequency is the lowest.

#### NOTE:

- *Auto store can be released by pressing AST button (7) while auto store is under way.*
- *When the auto store is performed, the station previously stored in the memory at the position is overwritten.*
- *When there are fewer than 6 stations that can be stored even if 1 round of auto store operation is performed, no station will be stored at the remaining Preset buttons (6).*
- *6 stations can be preset for FM1 and FM2 in common, and 6 stations for AM in auto store mode.*

### Auto store mode on/off

Press the AST button (7).

Each time the button is pressed, the mode is switched as follows:

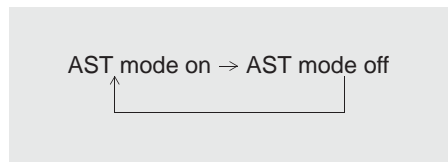

### Radio Reception

Radio reception can be affected by environment, atmospheric conditions, or radio signal's power and distance from the station. Nearby mountains and buildings may interfere or deflect radio reception, causing poor reception. Poor reception or radio static can also be caused by electric current from overhead wires or high voltage power lines.

Listening to a CD

EXAMPLE

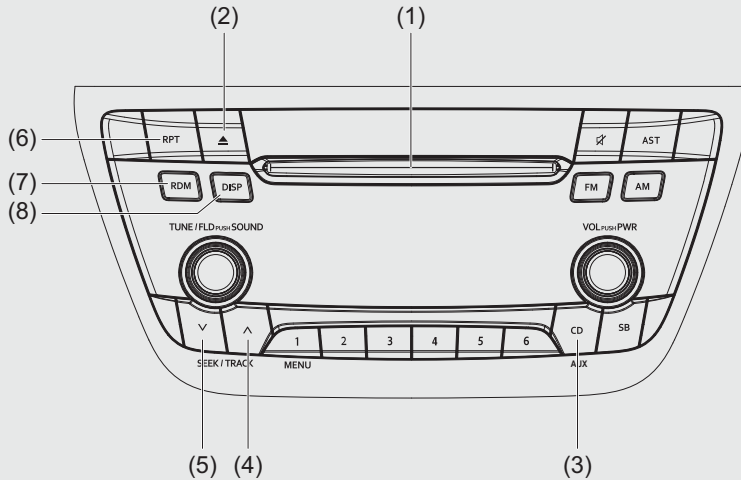

Display

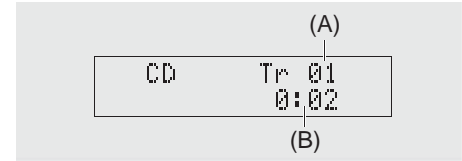

- (1) Insertion slot
- (2) Eject button
- (3) CD button
- (4) Up button
- (5) Down button
- (6) RPT button
- (7) RDM button
- (8) DISP button

(A) Track number

(B) Play time

NOTE:

*This product does not support 8 cm CD (sometimes called as "mini single CD", "3-inch CD", "CD3", etc.).*

64MS189

## OTHER CONTROLS AND EQUIPMENT



- CDs or CD-ROMs carrying no mark (A) cannot be used.
- Some discs recorded in CD-R/CD-RW format may sometimes be impossible to use.

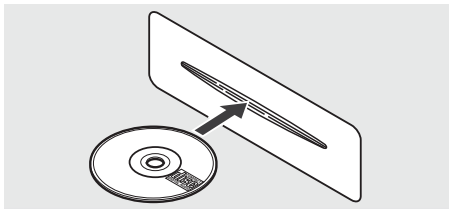

- A CD is to be inserted with its label side up.
- When there is a CD already in the unit, it is impossible to insert another CD without ejecting the CD in the unit. Do not use force to insert a CD into the CD insertion slot.

### NOTICE

- **Never insert your finger or hand into the CD insertion slot. Never insert foreign objects.**
- **Never insert a CD with glue coming out from adhesive tape or a rental CD label or with a trace indicating that adhesive tape or a rental CD label has been removed. This may cause the CD not to eject or result in a malfunction.**

### Selecting a CD mode

Press the CD button (3).

Each time the button is pressed, the mode will change as follows:

CD ←  
↓  
Bluetooth® audio (if equipped)  
↓  
AUX (if equipped)

### Loading a CD

Insert a CD in the Insertion slot (1).  
When a CD is loaded, play starts.

### Ejecting a CD

Press the Eject button (2).

When the ignition mode is LOCK (OFF) or the ignition switch is in the “LOCK” position, the CD remained ejected for around 15 seconds or longer will automatically be drawn inside the unit. (Auto reload function)

The backup eject function:

This function allows you to eject a CD by pressing the Eject button (2) even when the ignition mode is “LOCK” (OFF) or the ignition switch is in the “LOCK” position.

### NOTICE

**If you forcefully try to push an ejected CD inside the unit before auto reloading, the disc surface might be scratched.**  
**When reloading a CD, remove it from the unit completely before reloading.**

### Listening to a CD

When a CD is inserted, playback will automatically start.

When a CD is already inside the unit, press the CD button (3) to start playback.

### Selecting a track

- Press the Up button (4) to listen to the next track.
- Press the Down button (5) twice to listen to the previous track.  
When the Down button (5) is pressed once, the track currently being played will start from the beginning again.

### Fast forwarding/Rewinding a track

- Hold down the Up button (4) to fast forward the track.
- Hold down the Down button (5) to fast rewind the track.

### Random playback

Press the RDM button (7).

Each time the button is pressed, the mode will change as follows:

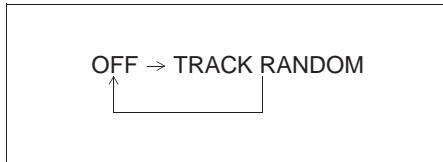

- **TRACK RANDOM**  
The random indicator "RDM" will light. The tracks in the loaded disc will be played in random order.

### Repeat playback

Press the RPT button (6).

Each time the button is pressed, the mode will change as follows:

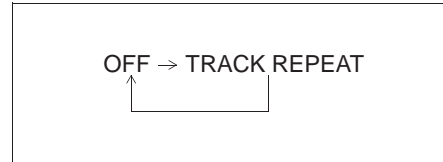

- **TRACK REPEAT**  
The repeat indicator "RPT" will light. The track currently being played will be played repeatedly.

### Display change

Press the DISP button (8).

Each time the button is pressed, display will change as follows:

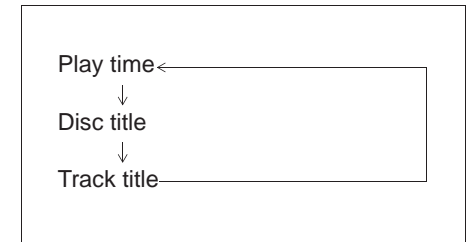

**NOTE:**

- "NO TITLE" will be displayed when there is no text information in the disc currently being played.
- If text data contains more than 12 characters, the ">" mark will appear at the right end. Holding down the DISP button (8) for 1 second or longer can display the next page.

## OTHER CONTROLS AND EQUIPMENT

### Listening to an MP3/WMA/AAC Disc

### Display

#### EXAMPLE

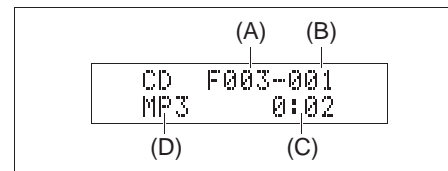
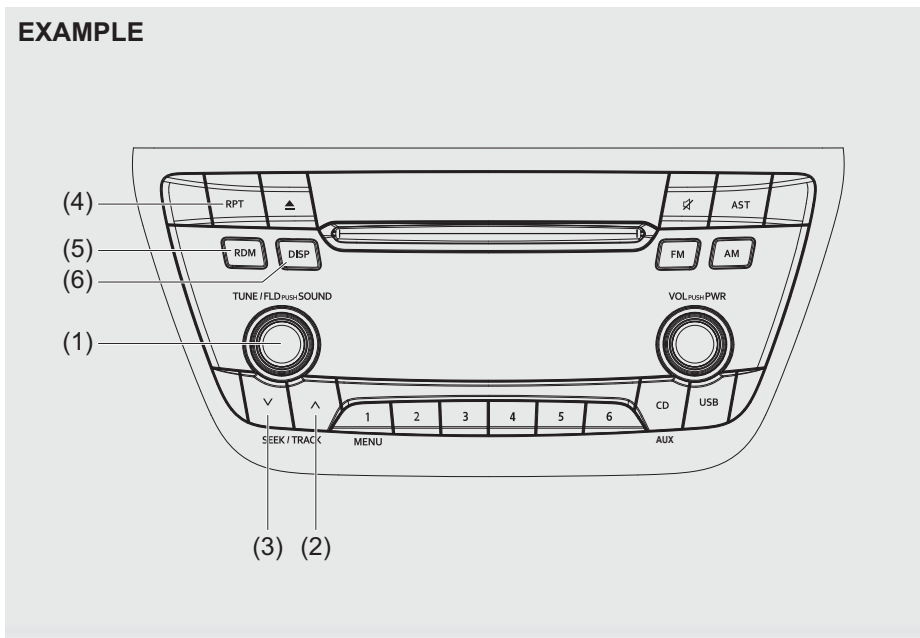

- (1) TUNE FOLDER PUSH SOUND knob
- (2) Up button
- (3) Down button
- (4) RPT button
- (5) RDM button
- (6) DISP button
  
- (A) Folder number
- (B) Track number
- (C) Play time
- (D) DISC type

64MS190

### Selecting a folder

Turn the TUNE FOLDER PUSH SOUND knob (1) to select a folder.

### Selecting a track

- Press the Up button (2) to listen to the next track.
- Press the Down button (3) twice to listen to the previous track. When the Down button (3) is pressed once, the track currently being played will start from the beginning again.

### Fast forwarding/Rewinding a track

- Hold down the Up button (2) to fast forward the track.
- Hold down the Down button (3) to fast rewind the track.

### Random playback

Press the RDM button (5).

Each time the button is pressed, the mode will change as follows:

OFF → FOLDER RANDOM → ALL RANDOM



- FOLDER RANDOM  
The random indicator "F.RDM" will light. The tracks in the current folder will be played in random order.
- ALL RANDOM  
The random indicator "RDM" will light. The tracks in the loaded disc will be played in random order.

### Repeat playback

Press the RPT button (4).

Each time the button is pressed, the mode will change as follows:

OFF → FILE REPEAT → FOLDER REPEAT



- FILE REPEAT  
The repeat indicator "RPT" will light. The track currently being played will be played repeatedly.
- FOLDER REPEAT  
The repeat indicator "F.RPT" will light. All tracks in the currently selected folder will be played repeatedly.

## OTHER CONTROLS AND EQUIPMENT

### Display change

Press the DISP button (6).

Each time the button is pressed, display will change as follows:

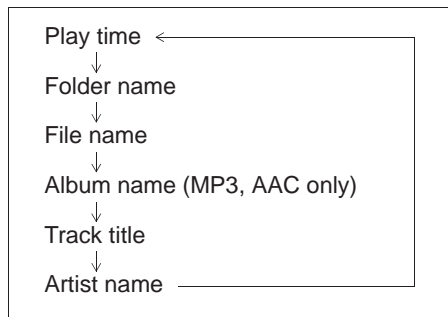

### NOTE:

- “NO TITLE” will be displayed when there is no text information in the disc currently being played.
- If text data contains more than 12 characters, the “>” mark will appear at the right end. Holding down the DISP button (6) for 1 second or longer can display the next page.

### Notes on MP3/WMA/AAC

#### What is MP3?

- MP3 (MPEG audio layer3) is an audio compression format that has become the standard format among PC users. Its merit is that the original audio data is compressed to approximately 1/10 and high sound quality is maintained. This means that it is possible to store the data of approximately 10 music CDs on a single CD-R/RW disc, which in turn makes it possible to play music for a long time without having to change the disc.

#### What is WMA?

- An abbreviation of “Windows Media Audio,” WMA is an audio compression format developed by Microsoft.
- WMA files for which the DRM (Digital Rights Management) function is ON cannot be played.
- Windows Media™ and the Windows® logo are trademarks or registered trademarks of Microsoft Corporation in the United States and other countries.

#### What is AAC?

- An abbreviation of “Advanced Audio Coding,” AAC is an audio compression format used by MPEG2 and MPEG4.

### Points to remember when making MP3/WMA/AAC files

#### Common

- High bit rate and high sampling frequency are recommended for high quality sounds.
- Selecting VBR (Variable Bit Rate) is not recommended. Selecting VBR may cause display of incorrect playing time and jumpiness of playback.
- Playback sound quality varies depending on the encoding environment. For details, refer to the user manual of the encoding software and the writing software in use.

### NOTICE

**Never assign the “.mp3”, “.wma”, or “.m4a” file name extension to a file if it is not in the MP3/WMA/AAC format file. Failure to observe this may result in damage to the speaker due to noise production.**



### Recording MP3/WMA/AAC files on a CD media

- It is recommended not to write both CD-DA files and MP3/WMA/AAC files on a disc.
- If both CD-DA files and MP3/WMA/AAC files are on the same disc, tracks may not be played in the correct order or some tracks may not be played at all.
- When storing both MP3 data and WMA data on the same disc, sort and place them in different folders.
- Do not write files other than MP3/WMA/AAC files and unnecessary folders on a disc.
- MP3/WMA/AAC files should be named to meet the standards and the file system specifications as shown below.
- The file extension “.mp3”, “.wma” or “.m4a” should be assigned to files based on their format independently.
- You may encounter a trouble in playing MP3/WMA/AAC files or displaying information of MP3/WMA/AAC files depending on the writing software or CD recorder in use.
- This unit does not have a play list function.
- It is recommended to write discs in Disc-at-Once mode even though Multi-session mode is supported.

### Compression formats

#### MP3

- Bit rate:
  - MPEG1 Audio Layer III: 32 k - 320 kbps
  - MPEG2 Audio Layer III: 8 k - 160 kbps
  - MPEG2.5 Audio Layer III: 8 k - 160 kbps
- Sampling frequency:
  - MPEG1 Audio Layer III: 32 k/44.1 k/48 kHz
  - MPEG2 Audio Layer III: 16 k/22.05 k/24 kHz
  - MPEG2.5 Audio Layer III: 8 k/11.025 k/12 kHz

#### WMA (Ver. 7, Ver. 8, Ver. 9\*)

- Bit rate: CBR 32 k - 320 kbps
- Sampling frequency: 32 k/44.1 k/48 kHz
- \* WMA 9 Professional/LossLess/Voice are not supported.

#### AAC\*

- Bit rate: ABR 16k - 320 kbps
- Sampling frequency: 32 k/44.1 k/48 kHz
- \* Apple Lossless is not supported.

### Supported file systems

ISO 9660 Level 1/Level 2, Joliet, Romeo

### Maximum number of files/folders

- Maximum number of files: 512 (files + folders)
- Maximum number of files in a folder: 255
- Maximum depth of tree structure: 8
- Maximum number of folders: 255 (Root folder is included.)

## OTHER CONTROLS AND EQUIPMENT

### Listening to files stored in a USB device (if equipped)

#### EXAMPLE

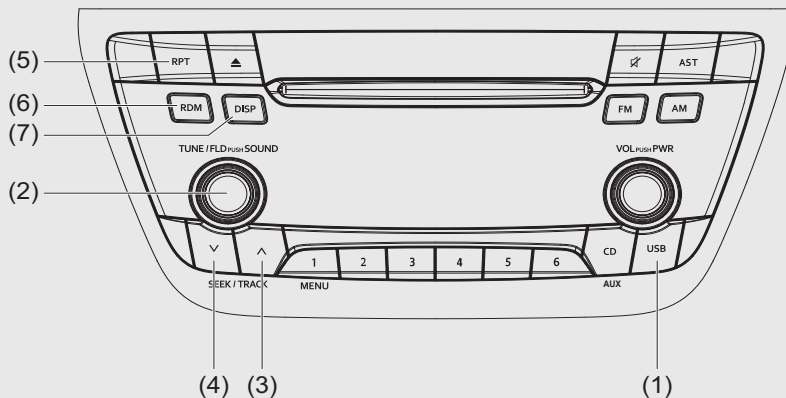

64MS191

#### Display

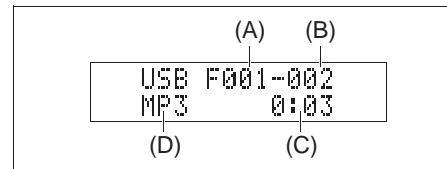

- (1) USB button
- (2) TUNE FOLDER PUSH SOUND knob
- (3) Up button
- (4) Down button
- (5) RPT button
- (6) RDM button
- (7) DISP button
- (A) Folder number
- (B) Track number
- (C) Play time
- (D) File type

#### **NOTICE**

**Do not connect any USB device other than a USB memory or a USB audio player. Do not connect multiple USB devices to the USB connector using a USB hub, etc. Supplying power to multiple USB devices from the connector could cause overheating and smoking.**

### Selecting a USB device mode

Press the USB button (1).

### Selecting a folder

Turn the TUNE FOLDER PUSH SOUND knob (2) to select the desired folder.

### Selecting a track

- Press the Up button (3) to listen to the next track.
- Press the Down button (4) twice to listen to the previous track.  
When the Down button (4) is pressed once, the track currently being played will start from the beginning again.

### Fast forwarding/Rewinding a track

- Hold down the Up button (3) to fast forward the track.
- Hold down the Down button (4) to fast rewind the track.

### Random playback

Press the RDM button (6).

Each time the button is pressed, the mode will change as follows:

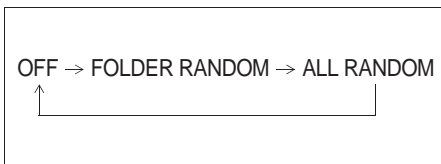

- FOLDER RANDOM  
The random indicator “F.RDM” will light. The tracks in the currently selected folder will be played in random order.

- ALL RANDOM  
The random indicator “RDM” will light. The tracks in the connected USB device will be played in random order.

### Repeat playback

Press the RPT button (5).

Each time the button is pressed, the mode will change as follows:



- FILE REPEAT  
The repeat indicator “RPT” will light. The track currently being played will be played repeatedly.
- FOLDER REPEAT  
The repeat indicator “F.RPT” will light. All the tracks in the folder currently selected will be played repeatedly.

### Display change

Press the DISP button (7).

Each time the button is pressed, display will change as follows:

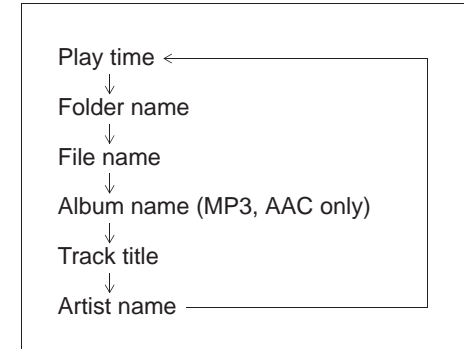

### NOTE:

- “NO TITLE” will be displayed when there is no text information in the disc currently being played.
- If text data contains more than 12 characters, the “>” mark will appear at the right end. Holding down the DISP button (7) for 1 second or longer can display the next page.

## OTHER CONTROLS AND EQUIPMENT

---

### Notes on USB device

#### Compatible USB devices

- USB Mass Storage Class  
For details as to whether your USB memory/USB Audio is compatible with USB Mass Storage Class, please contact the USB memory/USB Audio manufacturer.
- USB Standard Compatibility 1.1/2.0 Full Speed
- File System FAT12/16/32, VFAT
- Maximum current less than 1.0 A
- If devices such as USB hub, extension cable are connected to the audio system, it may not be recognized. In such case connect the USB device directly to the audio system.
- Devices such as MP3 player/Mobile phone/digital camera may not be recognized by the audio system for playing music.

#### USB device connection

- When connecting a USB device, make sure that the connector is pushed all the way into the port.
- Do not leave the USB device for long periods of time in places inside the vehicle where the temperature can rise too high.
- Back up any important data beforehand. We cannot accept responsibility for any lost data.
- It is recommended not to connect a USB device that contains data files other than MP3/WMA/AAC format.

#### Recording MP3/WMA/AAC files on a USB device

- Playback or display may not be possible depending on the type of USB device in use or the condition of the recording.
- Depending on the connected USB memory, the files may be played in different order from the order that the files were stored.

#### Compression formats

##### MP3

- Bit rate:  
MPEG1 Audio Layer III: 32 k - 320 kbps  
MPEG2 Audio Layer III: 8 k - 160 kbps  
MPEG2.5 Audio Layer III: 8 k - 160 kbps
- Sampling frequency:  
MPEG1 Audio Layer III: 32 k/44.1 k/48 kHz  
MPEG2 Audio Layer III: 16 k/22.05 k/24 kHz  
MPEG2.5 Audio Layer III: 8 k/11.025 k/12 kHz

##### WMA (Ver. 7, Ver. 8, Ver. 9\*)

- Bit rate: CBR 32 k - 320 kbps
- Sampling frequency: 32 k/44.1 k/48 kHz
- \* WMA 9 Professional/LossLess/Voice are not supported.

##### AAC\*

- Bit rate: ABR 16k - 320 kbps
- Sampling frequency: 32 k/44.1 k/48 kHz
- \* Apple Lossless is not supported.

#### Maximum number of files/folders

- Maximum number of files: 2500 (files + folders)
- Maximum number of files in a folder: 255
- Maximum depth of tree structure: 8
- Maximum number of folders: 255 (Root folder is included.)

## Listening to an iPod® (if equipped)

### EXAMPLE

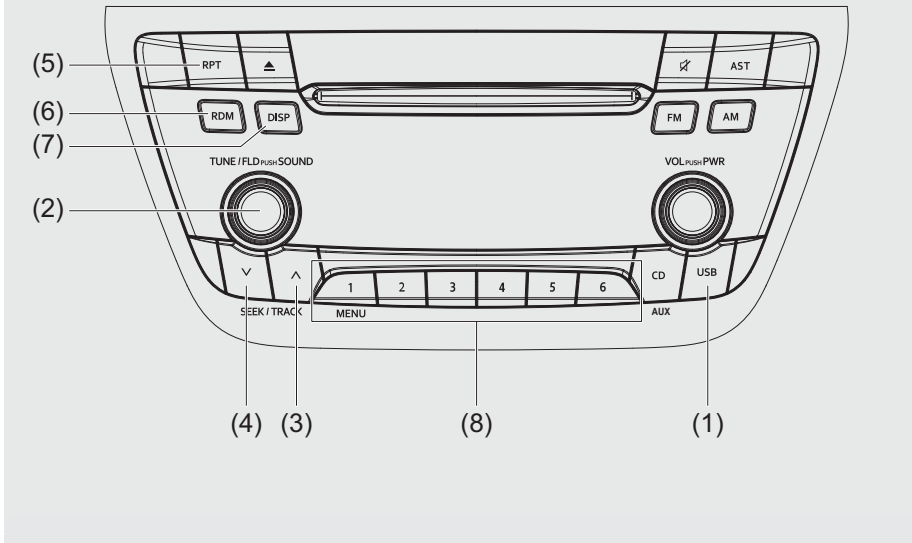

64MS192

### Display

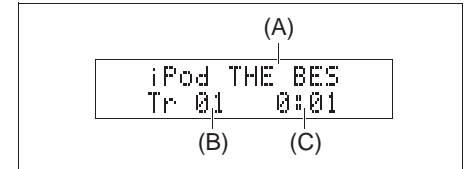

- (1) USB button
- (2) TUNE FOLDER PUSH SOUND knob
- (3) Up button
- (4) Down button
- (5) RPT button
- (6) RDM button
- (7) DISP button
- (8) Preset buttons ([1] to [6])
- (A) Track title
- (B) Track number
- (C) Play time

## OTHER CONTROLS AND EQUIPMENT

### Selecting an iPod® mode

Press the USB button (1).

### Selecting a track

- Press the Up button (3) to listen to the next track.
- Press the Down button (4) twice to listen to the previous track.  
When the Down button (4) is pressed once, the track currently being played will start from the beginning again.

### Fast forwarding/Rewinding a track

- Hold down the Up button (3) to fast forward the track.
- Hold down the Down button (4) to fast rewind the track.

### Random playback

Press the RDM button (6).

Each time the button is pressed, the mode will change as follows:

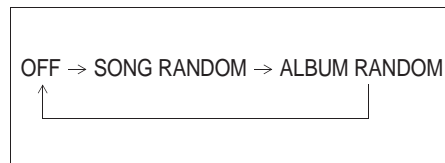

- SONG RANDOM  
The random indicator “RDM” will light.  
The tracks in the iPod® will be played in random order.
- ALBUM RANDOM  
The random indicator “F.RDM” will light.  
The albums in the iPod® will be played in random order.

### Repeat playback

Press the RPT button (5).

Each time the button is pressed, the mode will change as follows:

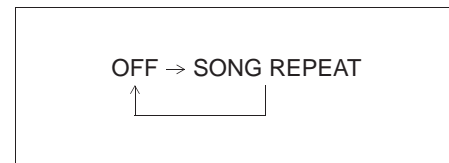

- SONG REPEAT  
The repeat indicator “RPT” will light.  
The track currently being played will be played repeatedly.

### Display change

Press the DISP button (7).

Each time the button is pressed, display will change as follows:

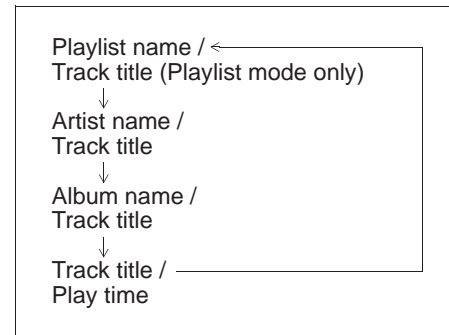

**NOTE:**

If text data contains more than 12 characters, the ">" mark will appear at the right end. Holding down the DISP button (7) for 1 second or longer can display the next page.

**Playing Mode selection**

- 1) Press the button numbered [6] of the Preset buttons (8) for 1 second or longer.
- 2) Turn the TUNE FOLDER PUSH SOUND knob (2). Each time the knob is turned, the mode will change as follows:

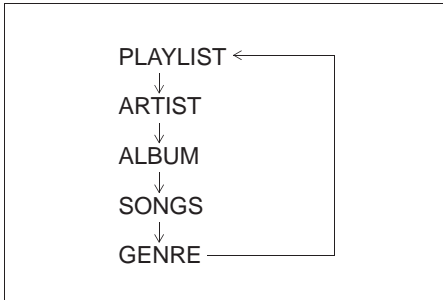

- 3) Press the TUNE FOLDER PUSH SOUND knob (2) to select the desired mode.

**NOTE:**

- When the button numbered [6] of the Preset buttons (8) is pressed, the previous mode will be displayed.

**Notes on iPod®  
Supported iPod®**

- iPod® touch (5th generation)
- iPod® touch (4th generation)
- iPod® touch (3rd generation)
- iPod® touch (2nd generation)
- iPod® touch (1st generation)
- iPod® classic
- iPod® nano (7th generation)
- iPod® nano (6th generation)
- iPod® nano (5th generation)
- iPod® nano (4th generation)
- iPod® nano (3rd generation)
- iPod® nano (2nd generation)
- iPod® nano (1st generation)
- iPod® (5th generation)
- iPod® (6th generation)
- iPod® (6thPlus generation)
- iPhone® 6 / 6 plus
- iPhone® 5
- iPhone® 4S
- iPhone® 4
- iPhone® 3GS
- iPhone® 3G
- iPhone®

\* Some functions may not be available depending on the model of iPod®.

\* iPod® is a trademark of Apple Inc., registered in the U.S. and other countries.

\* iPhone® is a trademark of Apple Inc., registered in the U.S. and other countries.

\* Apple is not responsible for the operation of this device or its compliance with safety and regulatory standards.

**iPod® connection**

- Make sure to detach the iPod® after pressing the engine switch to change the ignition mode to "LOCK" (OFF) or the ignition switch is turned to the "LOCK" position. The iPod® may not be shut down when it is being connected and may result in battery depletion.
- Please do not connect iPod® accessories such as an iPod® remote control or headphones while connecting the iPod® with the unit. The unit may not operate correctly.

## OTHER CONTROLS AND EQUIPMENT

### AUX Function

#### EXAMPLE

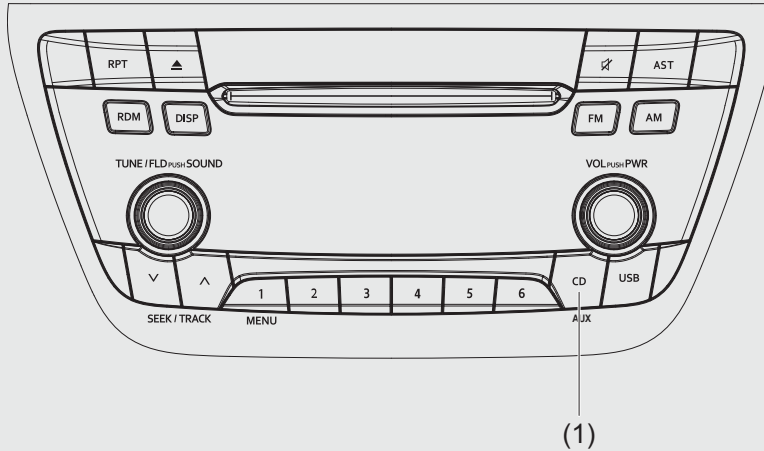

(1) CD button

64MS193

### AUX connection

To listen to auxiliary audio sources (sold separately) through the unit, follow the instruction below.

- 1) Connect the auxiliary audio source to the AUX/USB socket (separately attached) with an AUX cable.
- 2) Press the CD button (1).  
Each time the button is pressed, the mode will change as follows:

CD ←  
↓  
Bluetooth® audio (if equipped)  
↓  
AUX (if equipped)

### ⚠ CAUTION

- Before connection, mute the unit, and also keep the volume of the auxiliary audio source within a range that will not cause distortion.
- When the audio source is turned off, noise may be emitted. Be sure to turn off the unit or switch to another mode before turning off the audio source.



*NOTE:*

- *Please consult your place of purchase for details about whether a given auxiliary audio source can be connected and the proper auxiliary cord to use.*
- *The volume and tone controls of the auxiliary audio source can be adjusted on the unit.*
- *In AUX mode, the volume setting is different from another mode.*

## OTHER CONTROLS AND EQUIPMENT

### Bluetooth® Hands-Free (if equipped)

#### EXAMPLE

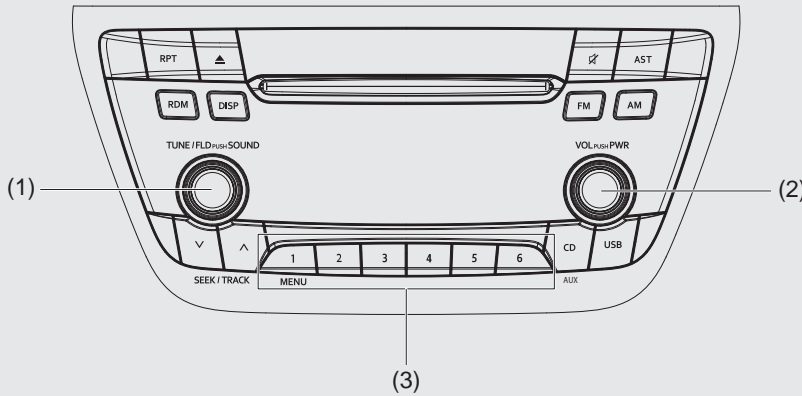

- (1) TUNE FOLDER PUSH SOUND knob
- (2) VOL PUSH POWER knob
- (3) Preset buttons

64MS194

### Steering switch

#### EXAMPLE

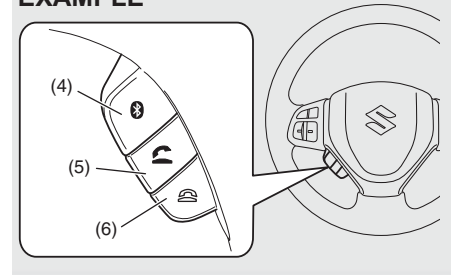

#### EXAMPLE

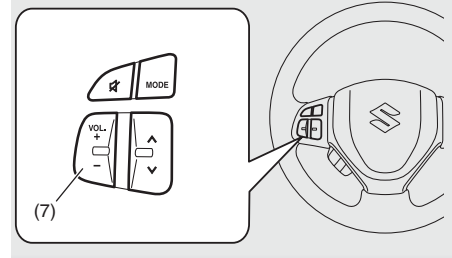

- (4) Bluetooth® setup button
- (5) Off Hook button
- (6) On Hook button
- (7) VOL switch

### Phone registration

To use the hands-free function with this unit, it is required to register the phone in advance.

#### NOTE:

- *Up to 5 phones can be registered.*
  - *To set up a new phone, disconnect the audio player from the unit. Connect the audio player again after phone setup is completed if necessary.*
  - *When failed to establish the pairing within 120 seconds, the connecting operation will be canceled. Please try again or refer to the manual of the phone in use for how to establish the pairing with the phone.*
- 1) Press the Bluetooth® setup button (4).  
The Bluetooth® setup menu will be displayed.
  - 2) Turn the TUNE FOLDER PUSH SOUND knob (1) to select “Setup Bluetooth”, and press the knob (1) to determine the selection.
  - 3) Turn the TUNE FOLDER PUSH SOUND knob (1) to select “Pairing”, and press the knob (1) to determine the selection.
  - 4) Select “CAR AUDIO” from the Bluetooth® menu of the phone and establish the pairing.  
Refer to the manual of the phone in use for further information.
  - 5) Enter the Passkey displayed on the unit to the phone. (For phones with Bluetooth® version 2.1 or above passkey input is not required.)

- 6) Press the On Hook button (6).

#### NOTE:

- *When selecting “Go Back”, the previous menu will be displayed.*
- *When additionally registering a phone, operate the same step from 1).*

#### Receiving a call

Press the Off Hook button (5) to receive a call.

#### Ending a call

Press the On Hook button (6) to end a call.

#### Rejecting a call (only for supported models)

Press the On Hook button (6) to reject a incoming call.

#### Adjusting the listening volume

- Turn the VOL PUSH POWER knob (2) during a call.  
Turning it clockwise increases the volume; turning it counterclockwise decreases the volume.
- Press the VOL switch (7) during a call. Pressing “+” of the switch increases the volume, pressing “-” of the switch decreases the volume.

#### Adjusting the ring volume

- Turn the VOL PUSH POWER knob (2) while a call coming in.  
Turning it clockwise increases the volume; turning it counterclockwise decreases the volume.
- Press the VOL switch (7) during a call. Pressing “+” of the switch increases the volume, pressing “-” of the switch decreases the volume.

#### Adjusting the call or ringtone volume

Follow the instructions below to adjust the call or ringtone volume.

- 1) Press the Bluetooth® setup button (4).  
The Bluetooth® setup menu will be displayed.
- 2) Turn the TUNE FOLDER PUSH SOUND knob (1) to select “Setup Telephone”, and press the knob (1) to determine the selection.
- 3) Turn the TUNE FOLDER PUSH SOUND knob (1) to select “Sound Setting”, and press the knob (1) to determine the selection.

## OTHER CONTROLS AND EQUIPMENT

---

- 4) Turn the TUNE FOLDER PUSH SOUND knob (1) to select “Call Volume” or “Ringtone Volume”, and press the knob (1) to determine the selection. The current call or ringtone volume will be displayed.
- 5) Turn the TUNE FOLDER PUSH SOUND knob (1) to select desired call or ringtone volume, and press the knob (1) to determine the selection.

### NOTE:

*When selecting “Go Back”, the previous menu will be displayed.*

### Selecting the Ringtone

Follow the instructions below to select a ringtone.

- 1) Press the Bluetooth® setup button (4). The Bluetooth® setup menu will be displayed.
- 2) Turn the TUNE FOLDER PUSH SOUND knob (1) to select “Setup Telephone”, and press the knob (1) to determine the selection.
- 3) Turn the TUNE FOLDER PUSH SOUND knob (1) to select “Sound Setting”, and press the knob (1) to determine the selection.
- 4) Turn the TUNE FOLDER PUSH SOUND knob (1) to select “Ringtone”, and press the knob (1) to determine the selection. The current ringtone will be sounded.
- 5) Turn the TUNE FOLDER PUSH SOUND knob (1) to select desired ring-

tone, and press the knob (1) to determine the selection.

### NOTE:

*When selecting “Go Back”, the previous menu will be displayed.*

### Dialing using Missed/Incoming/Outgoing Calls

Follow the instructions below to dial to the last dialed number again.

### NOTE:

*Up to 10 phone numbers of the latest calls can be stored. (10 each for dialed, received and missed call)*

- 1) Press the Off Hook button (5). The Bluetooth® phonebook menu will be displayed.
- 2) Turn the TUNE FOLDER PUSH SOUND knob (1) to select “Missed Calls”, “Incoming Calls” or “Outgoing Calls”, and press the knob (1) to determine the selection. To dial from the dialed history or the received history, select “Missed Calls”, “Incoming Calls” or “Outgoing Calls” respectively.
- 3) Turn the TUNE FOLDER PUSH SOUND knob (1) to select the desired number, and press the knob (1) to determine the selection.
- 4) Turn the TUNE FOLDER PUSH SOUND knob (1) to select “Dial”, and press the knob (1) or the Off Hook button (5) to dial to the selected number.

### NOTE:

- When selecting “Go Back”, the previous menu will be displayed.
- Pressing “Confirm” after selecting “Add Speed Dial” can register the selected number in the speed dial.
- Pressing “Confirm” after selecting “Delete” can delete the selected number from the call history.

### Deletion of call history

Follow the instructions below to delete a missed/incoming/outgoing call history.

- 1) Press the Off Hook button (5). The Bluetooth® phonebook menu will be displayed.
- 2) Turn the TUNE FOLDER PUSH SOUND knob (1) to select “Setup Phonebook”, and press the knob (1) to determine the selection.
- 3) Turn the TUNE FOLDER PUSH SOUND knob (1) to select “Delete History”, and press the knob (1) to determine the selection.
- 4) Turn the TUNE FOLDER PUSH SOUND knob (1) to select “Missed Calls”, “Incoming Calls”, or “Outgoing Calls”, and press the knob (1) to determine the selection.
- 5) Turn the TUNE FOLDER PUSH SOUND knob (1) to select a number to be deleted or “ALL”, and press the knob (1) to determine the selection.
- 6) Turn the TUNE FOLDER PUSH SOUND knob (1) to select “Delete?” or

“Delete All?”, and press the knob (1) to determine the selection.

- 7) Turn the TUNE FOLDER PUSH SOUND knob (1) to select “Confirm”, and press the knob (1) to complete the deletion.

**NOTE:**

*When selecting “Go Back”, the previous menu will be displayed.*

### Registration in Phonebook

Registration of numbers in the phonebook. Follow the instructions below to register phone numbers in the Phonebook of the unit.

- 1) Press the Bluetooth® setup button (4). The Bluetooth® setup menu will be displayed.
- 2) Turn the TUNE FOLDER PUSH SOUND knob (1) to select “Setup Telephone”, and press the knob (1) to determine the selection.
- 3) Turn the TUNE FOLDER PUSH SOUND knob (1) to select “Setup Phonebook”, and press the knob (1) to determine the selection.
- 4) Turn the TUNE FOLDER PUSH SOUND knob (1) to select “Add Contacts”, and press the knob (1) to determine the selection.
- 5) Turn the TUNE FOLDER PUSH SOUND knob (1) to select “Overwrite All” or “Add One Contact”, and press the knob (1) to determine the selection. The “Rest of Memory XXXX: Ok?” will be displayed.

- 6) Press or turn the TUNE FOLDER PUSH SOUND knob (1) to select “Confirm”, and press the knob (1) to determine the selection.

- 7) Transfer contacts from the phone. When the registration is completed, the “Setup Phonebook” will be displayed.

**NOTE:**

- When selecting “Go Back” the previous menu will be displayed.
- Up to 1000 numbers can be registered in Phonebook.

### Transfer of call history (Call History)

Follow the instructions below to transfer call history of the registered phone.

- 1) Press the Bluetooth® setup button (4). The Bluetooth® setup menu will be displayed.
- 2) Turn the TUNE FOLDER PUSH SOUND knob (1) to select “Setup Telephone”, and press the knob (1) to determine the selection.
- 3) Turn the TUNE FOLDER PUSH SOUND knob (1) to select “Call History”, and press the knob (1) to determine the selection.
- 4) Turn the TUNE FOLDER PUSH SOUND knob (1) to select “Call History?”, and press the knob (1) to determine the selection.
- 5) Turn the TUNE FOLDER PUSH SOUND knob (1) to select “Confirm”, and press the knob (1) to transfer the call history from the phone.

**NOTE:**

*When selecting “Go Back”, the previous menu will be displayed.*

### Making a call by Phonebook

Follow the instructions below to dial a number registered in Phonebook.

- 1) Press the Off Hook button (5). The Bluetooth® phonebook menu will be displayed.
- 2) Turn the TUNE FOLDER PUSH SOUND knob (1) to select “Phonebook”, and press the knob (1) to determine the selection.
- 3) Turn the TUNE FOLDER PUSH SOUND knob (1) to select the initial of the name you would like to make a call, and press the knob (1) to determine the selection. The registered numbers will be displayed in sequence. If names have been registered together with numbers, the names will be displayed.
- 4) Turn the TUNE FOLDER PUSH SOUND knob (1) to select “Dial”, and press the knob (1) to determine the selection.
- 5) Press the Off Hook button (5). The displayed number or the number registered with the displayed name will be dialed.

### Deletion of registered data (Delete Entry)

Follow the instructions below to delete a number registered in Phonebook.

## OTHER CONTROLS AND EQUIPMENT

---

- 1) Press the Bluetooth® setup button (4). The Bluetooth® setup menu will be displayed.
- 2) Turn the TUNE FOLDER PUSH SOUND knob (1) to select “Setup Telephone”, and press the knob (1) to determine the selection.
- 3) Turn the TUNE FOLDER PUSH SOUND knob (1) to select “Setup Phonebook”, and press the knob (1) to determine the selection.
- 4) Turn the TUNE FOLDER PUSH SOUND knob (1) to select “Delete Contacts”, and press the knob (1) to determine the selection.
- 5) Turn the TUNE FOLDER PUSH SOUND knob (1) to select a number to be deleted, and press the knob (1) to determine the selection.
- 6) Turn the TUNE FOLDER PUSH SOUND knob (1) to select “Delete?”, and press the knob (1) to determine the selection.
- 7) Turn the TUNE FOLDER PUSH SOUND knob (1) to select “Confirm”, and press the knob (1) to complete the deletion.

### NOTE:

*When selecting “Go Back”, the previous menu will be displayed.*

### Registration in speed dial

Follow the instructions below to assign a number to one of the Preset buttons to use as the speed dial.

- 1) Press the Bluetooth® setup button (4). The Bluetooth® setup menu will be displayed.
- 2) Turn the TUNE FOLDER PUSH SOUND knob (1) to select “Setup Telephone”, and press the knob (1) to determine the selection.
- 3) Turn the TUNE FOLDER PUSH SOUND knob (1) to select “Setup Phonebook”, and press the knob (1) to determine the selection.
- 4) Turn the TUNE FOLDER PUSH SOUND knob (1) to select “Add Speed Dial”, and press the knob (1) to determine the selection.
- 5) Turn the TUNE FOLDER PUSH SOUND knob (1) to select a number to be assigned, and press the knob (1) to determine the selection.
- 6) Turn the TUNE FOLDER PUSH SOUND knob (1) to select “Choose Preset”, and press the knob (1) to determine the selection.
- 7) Press one of the Preset buttons (3) to which the selected number is to be assigned. If a number is already assigned to the selected button, a confirmation message will be displayed. Turn the TUNE FOLDER PUSH SOUND knob (1) to select “Confirm”, and press the knob (1) to complete the assignment.  
When the assignment is completed, the “Setup Phonebook” will be displayed.

### NOTE:

*When selecting “Go Back”, the previous menu will be displayed.*

### One-touch call (Speed dial)

Follow the instructions below to dial the number assigned to each of the Preset buttons (3).

- 1) Press the Off Hook button (5).  
The Bluetooth® phonebook menu will be displayed.
- 2) Turn the TUNE FOLDER PUSH SOUND knob (1) to select “Speed Dials”, and press the knob (1) to determine the selection.
- 3) Press one of the Preset buttons (3).  
When no number is assigned, “No Entry” is displayed.
- 4) Press the Off Hook button (5).  
The selected number will be dialed.

### Deletion of speed dial (Del Speed Dial)

To delete a number assigned for the speed dial, follow the instructions below.

- 1) Press the Off Hook button (5).  
The Bluetooth® phonebook menu will be displayed.
- 2) Turn the TUNE FOLDER PUSH SOUND knob (1) to select “Speed Dials”, and press the knob (1) to determine the selection.
- 3) Press one of the Preset buttons (3) to which the number to be deleted is assigned.  
“No Entry” appears if the number is not registered.

- 4) Turn the TUNE FOLDER PUSH SOUND knob (1) to select “Delete”, and press the knob (1) to determine the selection.
- 5) Turn the TUNE FOLDER PUSH SOUND knob (1) to select “Del Speed Dial”, and press the knob (1) to determine the selection.
- 6) Turn the TUNE FOLDER PUSH SOUND knob (1) to select “Confirm”, and press the knob (1) to complete the deletion.

**NOTE:**

*When selecting “Go Back”, the previous menu will be displayed.*

**Display of device data (Device Name)**

Follow the instructions below to display the BD (Bluetooth® Device) address and device name.

- 1) Press the Bluetooth® setup button (4). The Bluetooth® setup menu will be displayed.
- 2) Turn the TUNE FOLDER PUSH SOUND knob (1) to select “Setup Bluetooth”, and press the knob (1) to determine the selection.
- 3) Turn the TUNE FOLDER PUSH SOUND knob (1) to select “Bluetooth Info”, and press the knob (1) to determine the selection.
- 4) Turn the TUNE FOLDER PUSH SOUND knob (1) to select “Device Name” or “Device Address”, and press the knob (1) to display the device name or the BD (Bluetooth® Device) address.

**NOTE:**

*When selecting “Go Back”, the previous menu will be displayed.*

**Reset to the factory defaults**

Follow the instructions below to reset all the settings to the factory defaults.

- 1) Press the Bluetooth® setup button (4). The Bluetooth® setup menu will be displayed.
- 2) Turn the TUNE FOLDER PUSH SOUND knob (1) to select “Setup Bluetooth”, and press the knob (1) to determine the selection.
- 3) Turn the TUNE FOLDER PUSH SOUND knob (1) to select “Initialize”, and press the knob (1) to determine the selection.
- 4) Turn the TUNE FOLDER PUSH SOUND knob (1) to select “All Initialize”, and press the knob (1) to determine the selection.
- 5) Turn the TUNE FOLDER PUSH SOUND knob (1) to select “Confirm”, and press the knob (1) to start the reset.

**NOTE:**

*When selecting “Go Back”, the previous menu will be displayed.*

**Selection of phone (Select Phone)**

Follow the instructions below to select a phone to be paired with from the registered phones.

- 1) Press the Bluetooth® setup button (4). The Bluetooth® setup menu will be displayed.
- 2) Turn the TUNE FOLDER PUSH SOUND knob (1) to select “Setup Bluetooth”, and press the knob (1) to determine the selection.
- 3) Turn the TUNE FOLDER PUSH SOUND knob (1) to select “List Phone”, and press the knob (1) to determine the selection.
- 4) Turn the TUNE FOLDER PUSH SOUND knob (1) to select a phone to be paired with, and press the knob (1) to determine the selection.
- 5) Turn the TUNE FOLDER PUSH SOUND knob (1) to select “Select”, and press the knob (1) to determine the selection.

**NOTE:**

- *When selecting “Go Back”, the previous menu will be displayed.*
- *The Bluetooth® ready audio device will be disconnected when the phone is selected.*

**List of phones (List Phones)**

Follow the instructions below to display the names of the registered phones in sequence.

- 1) Press the Bluetooth® setup button (4). The Bluetooth® setup menu will be displayed.
- 2) Turn the TUNE FOLDER PUSH SOUND knob (1) to select “Setup Blue-

## OTHER CONTROLS AND EQUIPMENT

---

tooth”, and press the knob (1) to determine the selection.

- 3) Turn the TUNE FOLDER PUSH SOUND knob (1) to select “List Phone”, and press the knob (1) to determine the selection.

The names of the registered phones are displayed in sequence.

### NOTE:

*When selecting “Go Back”, the previous menu will be displayed.*

### Passkey setting (Set Passkey)

Follow the instructions below to set the security number (Passkey).

- 1) Press the Bluetooth® setup button (4).  
The Bluetooth® setup menu will be displayed.
- 2) Turn the TUNE FOLDER PUSH SOUND knob (1) to select “Setup Bluetooth”, and press the knob (1) to determine the selection.
- 3) Turn the TUNE FOLDER PUSH SOUND knob (1) to select “Passkey”, and press the knob (1) to determine the selection.
- 4) Turn the TUNE FOLDER PUSH SOUND knob (1) to select “New Passkey”, and press the knob (1) to determine the selection.
- 5) Press or turn the TUNE FOLDER PUSH SOUND knob (1) to select “Confirm”.
- 6) Turn the TUNE FOLDER PUSH SOUND knob (1) to select a number for the first digit, and press the knob (1) to

determine the selection. Select and determine numbers for the second, third and fourth digits in order in the same manner. When not entering up to the eighth digit, enter blanks for the successive digits.

- 7) Turn the TUNE FOLDER PUSH SOUND knob (1) to determine the passkey setting.

### NOTE:

*When selecting “Go Back”, the previous menu will be displayed.*

### Deletion of phone information (Delete Phone)

Follow the instructions below to delete the registered information of the phone.

- 1) Press the Bluetooth® setup button (4).  
The Bluetooth® setup menu will be displayed.
- 2) Turn the TUNE FOLDER PUSH SOUND knob (1) to select “Setup Bluetooth”, and press the knob (1) to determine the selection.
- 3) Turn the TUNE FOLDER PUSH SOUND knob (1) to select “List Phone”, and press the knob (1) to determine the selection.
- 4) Turn the TUNE FOLDER PUSH SOUND knob (1) to select a phone to be deleted, and press the knob (1) to determine the selection.
- 5) Turn the TUNE FOLDER PUSH SOUND knob (1) to select “Delete Phone”, and press the knob (1) to determine the selection.

- 6) Turn the TUNE FOLDER PUSH SOUND knob (1) to select “Delete?”, and press the knob (1) to determine the selection.

- 7) Turn the TUNE FOLDER PUSH SOUND knob (1) to select “Confirm”, and press the knob (1) to determine the selection.

### NOTE:

*When selecting “Go Back”, the previous menu will be displayed.*



### **BT function on/off (BT Power)**

Follow the instructions below to turn on/off the Bluetooth® function.

- 1) Press the Bluetooth® setup button (4).  
The Bluetooth® setup menu will be displayed.
- 2) Turn the TUNE FOLDER PUSH SOUND knob (1) to select “Setup Bluetooth”, and press the knob (1) to determine the selection.
- 3) Turn the TUNE FOLDER PUSH SOUND knob (1) to select “BT Power”, and press the knob (1) to determine the selection.
- 4) Press the TUNE FOLDER PUSH SOUND knob (1) to select “BT Power On” or “BT Power Off”.

#### *NOTE:*

- *When the BT function is turned off, the connection between this unit and the registered phone in use will be disconnected.*
- *When selecting “Go Back”, the previous menu will be displayed.*

## OTHER CONTROLS AND EQUIPMENT

### Bluetooth® audio (if equipped)

#### EXAMPLE

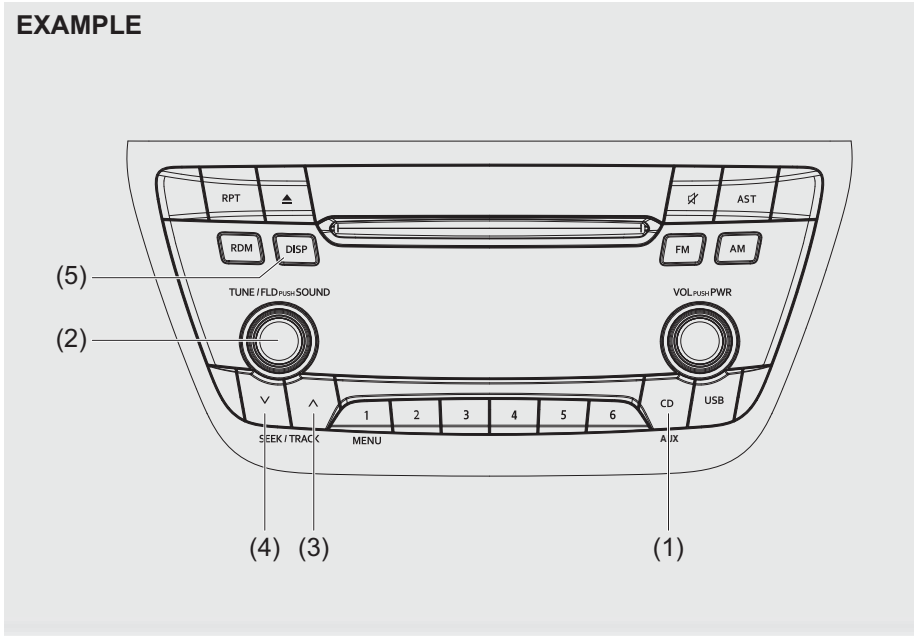

64MS195

### Steering switch

#### EXAMPLE

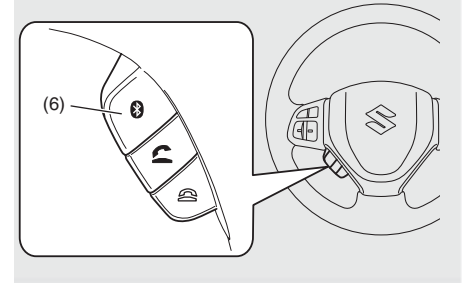

### Display

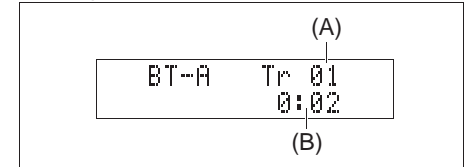

- (1) CD button
- (2) TUNE FOLDER PUSH SOUND knob
- (3) Up button
- (4) Down button
- (5) DISP button
- (6) Bluetooth® setup button

- (A) Track number
- (B) Play time

### Registration of audio devices

To use Bluetooth® ready audio devices with this unit, it is required to register the devices.

#### NOTE:

- To set up a new audio player, disconnect the phone from the unit. Connect the phone after audio player setup is completed if necessary.
  - When failed to establish the connection within 120 seconds, the connecting operation will be canceled. Please try again or refer to the audio player manual for assistance with the pairing process.
- 1) Press the Bluetooth® setup button (6).  
The Bluetooth® setup menu will be displayed.
  - 2) Turn the TUNE FOLDER PUSH SOUND knob (2) to select "Setup Bluetooth", and press the knob (2) to determine the selection.
  - 3) Turn the TUNE FOLDER PUSH SOUND knob (2) to select "Pairing", and press the knob (2) to determine the selection.
  - 4) Select "CAR AUDIO" from the Bluetooth® menu of the audio player and establish the pairing.  
Refer to the manual of the audio player in use for further information.
  - 5) Enter the Passkey displayed on the unit to the audio player.

#### NOTE:

- When selecting "Go Back", the previous menu will be displayed.
- When additionally registering audio devices, operate the same step from 1).

### Selecting the Bluetooth® audio mode

Press the CD button (1).

Each time the button is pressed, the mode will change as follows:

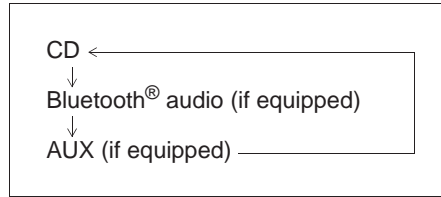

### Selecting a group (only for supported models)

Turn the TUNE FOLDER PUSH SOUND knob (2) to select a group.

### Selecting a track

- Press the Up button (3) to listen to the next track.
- Press the Down button (4) twice to listen to the previous track.  
When the Down button (4) is pressed once, the track currently being played will start from the beginning again.

### Fast forwarding/Rewinding a track

- Hold down the Up button (3) to fast forward the track.
- Hold down the Down button (4) to fast rewind the track.

#### NOTE:

Some functions may not be available depending on Bluetooth® audio.

### Display change

Press the DISP button (5).

Each time the button is pressed, display will change as follows:

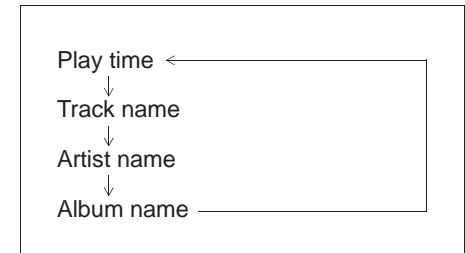

## OTHER CONTROLS AND EQUIPMENT

---

### NOTE:

If text data contains more than 12 characters, the ">" mark will appear at the right end. Holding down the DISP button (5) for 1 second or longer can display the next page.

### Selection of audio device (Select Audio)

Follow the instructions below to select an audio device to be paired with from the registered audio devices.

- 1) Press the Bluetooth® setup button (6). The Bluetooth® setup menu will be displayed.
- 2) Turn the TUNE FOLDER PUSH SOUND knob (2) to select "Setup Bluetooth", and press the knob (2) to determine the selection.
- 3) Turn the TUNE FOLDER PUSH SOUND knob (2) to select "List Audio", and press the knob (2) to determine the selection.
- 4) Turn the TUNE FOLDER PUSH SOUND knob (2) to select an audio device to be used, and press the knob (2) to determine the selection.
- 5) Turn the TUNE FOLDER PUSH SOUND knob (2) to select "Select", and press the knob (2) to determine the selection.
- 6) Turn the TUNE FOLDER PUSH SOUND knob (2) to select "Confirm", and press the knob (2) to complete the pairing.

### NOTE:

- When selecting "Go Back", the previous menu will be displayed.

- The phone will be disconnected when the Bluetooth® ready audio device is selected.

### List of audio devices (List Audio)

Follow the instructions below to display the names of the registered audio devices in sequence.

- 1) Press the Bluetooth® setup button (6). The Bluetooth® setup menu will be displayed.
- 2) Turn the TUNE FOLDER PUSH SOUND knob (2) to select "Setup Bluetooth", and press the knob (2) to determine the selection.
- 3) Turn the TUNE FOLDER PUSH SOUND knob (2) to select "List Audio", and press the knob (2) to determine the selection. The names of registered audio devices will be displayed in sequence.

### NOTE:

When selecting "Go Back", the previous menu will be displayed.

### Passkey setting (Set Passkey)

Follow the instructions below to set the security number (Passkey).

- 1) Press the Bluetooth® setup button (6). The Bluetooth® setup menu will be displayed.
- 2) Turn the TUNE FOLDER PUSH SOUND knob (2) to select "Setup Bluetooth", and press the knob (2) to determine the selection.
- 3) Turn the TUNE FOLDER PUSH SOUND knob (2) to select "Passkey", and press the knob (2) to determine the selection.
- 4) Turn the TUNE FOLDER PUSH SOUND knob (2) to select "New Passkey", and press the knob (2) to determine the selection.
- 5) Press or turn the TUNE FOLDER PUSH SOUND knob (2) to select "Confirm".
- 6) Turn the TUNE FOLDER PUSH SOUND knob (2) to select a number for the first digit, and press the knob (2) to determine the selection. Select and determine numbers for the second, third and fourth digits in order in the same manner. When not entering up to the eighth digit, enter blanks for the successive digits.
- 7) Turn the TUNE FOLDER PUSH SOUND knob (2) to determine the passkey setting.

### NOTE:

When selecting "Go Back", the previous menu will be displayed.

### Deletion of audio device information (Delete Audio)

Follow the instructions below to delete the registered information of audio device.

- 1) Press the Bluetooth® setup button (6).  
The Bluetooth® setup menu will be displayed.
- 2) Turn the TUNE FOLDER PUSH SOUND knob (2) to select “Setup Bluetooth”, and press the knob (2) to determine the selection.
- 3) Turn the TUNE FOLDER PUSH SOUND knob (2) to select “List Audio”, and press the knob (2) to determine the selection.
- 4) Turn the TUNE FOLDER PUSH SOUND knob (2) to select an audio device to be deleted, and press the knob (2) to determine the selection.
- 5) Turn the TUNE FOLDER PUSH SOUND knob (2) to select “Delete”, and press the knob (2) to determine the selection.
- 6) Turn the TUNE FOLDER PUSH SOUND knob (2) to select “Delete?”, and press the knob (2) to determine the selection.
- 7) Turn the TUNE FOLDER PUSH SOUND knob (2) to select “Confirm”, and press the knob (2) to complete the deletion.

#### NOTE:

When selecting “Go Back”, the previous menu will be displayed.

### Disclaimer for Bluetooth® function

- Depending on the mobile phone models, some phones may not be compatible fully or partially (some function may be restricted).
- Connectivity or voice quality may get affected depending on circumstances.
- After the ignition switch is turned to the “ON” position, the audio system takes few seconds to detect and connect to the Bluetooth® device (if already paired)
- Make sure that you are aware of all applicable lock laws and accordingly use Bluetooth® device.

### Remote Audio Controls (if equipped)

Controlling of basic functions of the audio system is available using the switches on the steering wheel.

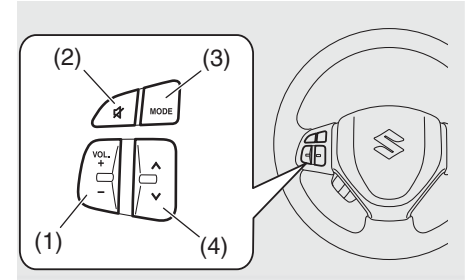

#### Adjusting the volume

- To increase the volume, hold down “+” of the VOL switch (1). The volume will keep on being increased until the switch is released.
- To decrease the volume, hold down “-” of the VOL switch (1). The volume will keep on being decreased until the switch is released.
- To mute the sound, press the switch (2).

#### Selecting the mode

Press the switch (3).

Each time the button is pressed, the mode will change as follows:

## OTHER CONTROLS AND EQUIPMENT

---

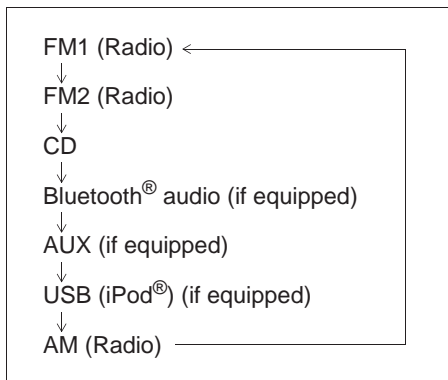

It is possible to turn on the audio system by pressing the switch (3).

### Selecting the radio station (FM1, FM2, AM mode)

- To select the next preset station, press “^” of the switch (4) only for a moment.
- To select the previous preset station, press “v” of the switch (4) only for a moment.
- To scan a higher frequency radio station, press “^” of the switch (4) for 1 second or longer.
- To scan a lower frequency radio station, press “v” of the switch (4) for 1 second or longer.

### Selecting the track (CD, USB (iPod®), Bluetooth® audio mode)

- To skip to the next track, press “^” of the switch (4) only for a moment.
- To skip to the previous track, press “v” of the switch (4) twice only for a moment. When the switch (4) is pushed down once only for a moment, the track currently being played will start from the beginning again.

### Fast forwarding/Rewinding a track

- To fast forward, press “^” of the switch (4) for 1 second or longer.
- To fast rewind, press “v” of the switch (4) for 1 second or longer.

### Anti-Theft Feature

#### EXAMPLE

- (1) VOL PUSH POWER knob
- (2) Preset buttons ([1] to [6])
- (3) Up button
- (4) TUNE FOLDER PUSH SOUND knob

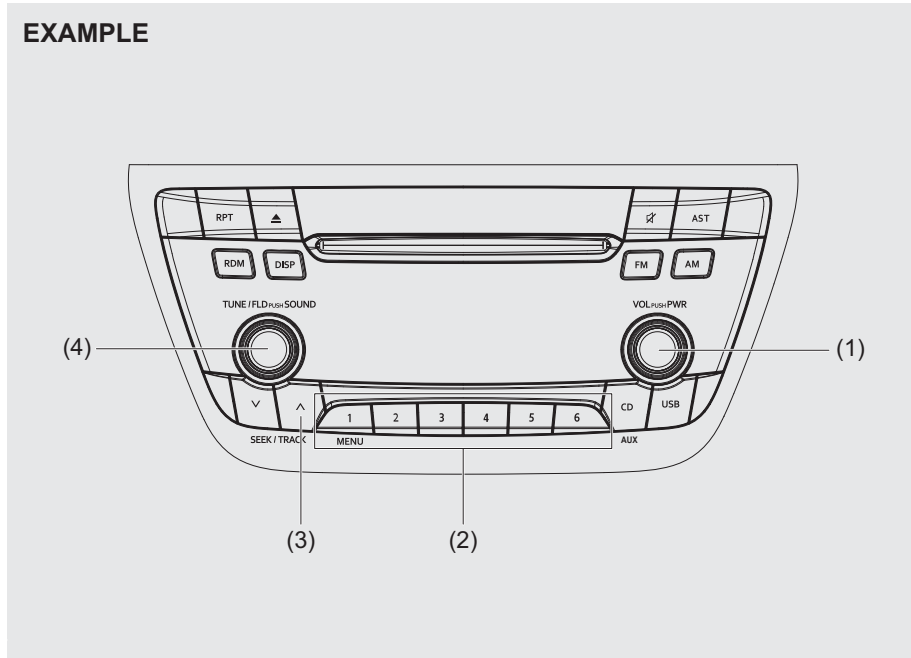

64MS196

## OTHER CONTROLS AND EQUIPMENT

---

The anti-theft function is intended to discourage thefts, such as that the audio system becomes inoperable when it is installed on other vehicles.

This function works by entering a Personal Identification Number (PIN).

When the unit is disconnected from its power source, such as when the audio system is removed or the battery is disconnected, the unit will become inoperable until the PIN is reentered.

### Setting the Anti-Theft Function

- 1) Press the VOL PUSH POWER knob (1) to power off.
- 2) Hold down the buttons numbered [1] and [6] of the Preset buttons (2) and press the VOL PUSH POWER knob (1). "SECURITY" will be displayed.
- 3) Press the Up button (3) and the button numbered [1] of the Preset buttons (2) simultaneously.
- 4) Enter a 4-digit number to be registered as PIN using the buttons numbered [1] - [4] of the Preset buttons (2).
- 5) Hold down the TUNE FOLDER PUSH SOUND knob (4) for 1 second or longer to set the anti-theft function.

#### NOTE:

*Take a note of the registered PIN and keep it for the future use.*

### Canceling the anti-theft feature

To cancel the anti-theft function, delete the registered PIN.

- 1) Press the VOL PUSH POWER knob (1) to power off.
- 2) Hold down the buttons numbered [1] and [6] of the Preset buttons (2) and press the VOL PUSH POWER knob (1). "PIN ENTRY" will be displayed.
- 3) Press the Up button (3) and the button numbered [1] of the Preset buttons (2) simultaneously.
- 4) Enter a 4-digit number to be registered as PIN using the buttons numbered [1] - [4] of the Preset buttons (2).
- 5) Hold down the TUNE FOLDER PUSH SOUND knob (4) for 1 second or longer to delete the registered PIN. The indication "----" will be displayed and the anti-theft function will be canceled.

#### NOTE:

*To change your PIN, first delete your current PIN, then set a new one.*

### Confirming the Personal Identification Number (PIN)

When the main power source is disconnected such as when the battery is replaced, etc, it is required to enter the PIN to make the unit operable again.

- 1) Set the ignition switch to the "ACC" position. "SECURITY" will be displayed.
- 2) Press the Up button (3) and the button numbered [1] of the Preset buttons (2) simultaneously.
- 3) Enter a 4-digit number to be registered as PIN using the buttons numbered [1] - [4] of the Preset buttons (2).
- 4) Hold down TUNE FOLDER PUSH SOUND knob (4) for 1 second or longer.

When the PIN same as registered is entered, the power of the audio system will be turned off automatically and it will become operable again.

#### NOTE:

*If an incorrect PIN is entered, "ERROR" and the total number of incorrect entry attempts will be displayed.*

*If an incorrect PIN is entered 10 times or more, "HELP" will be displayed and the audio system will become inoperable.*



### Battery Installation

Install a lithium battery (CR2025) with the poles facing the correct direction.

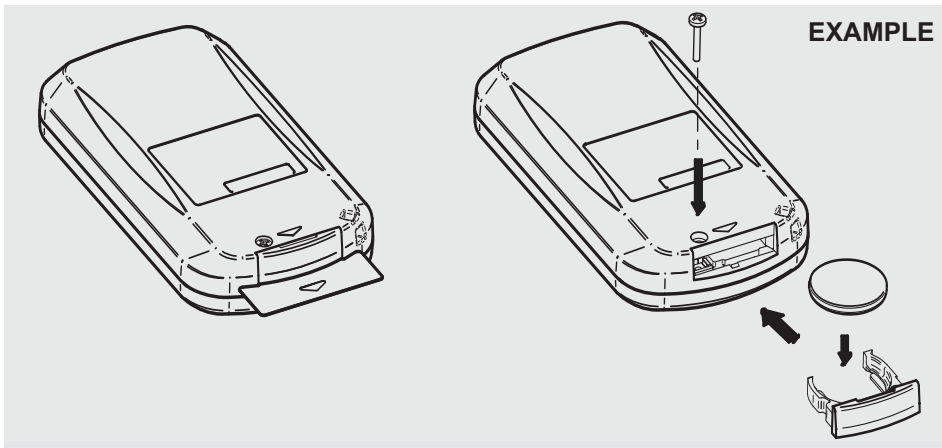

#### Battery replacement timing

- When battery power is depleted, the button may not be operable. If the remote controller does not operate, replace the battery and check the operation.

#### Caution on battery

- Be sure to follow the instructions to prevent battery leakage, over-heating, ignition or explosion.

#### ⚠ WARNING

- Do not expose the battery to flame. Do not short circuit, disassemble, or heat the battery.
  - Do not charge the battery.
  - Use the specified type battery.
  - Keep the button-shaped battery away from children to prevent accidental swallowing.
- If the battery is swallowed, contact a doctor immediately.

#### ⚠ CAUTION

- Install the battery with the poles facing the correct direction.
- When not in use for a long period of time, or if the battery is dead, remove the battery from the remote controller.

If battery leakage has occurred, wipe the container first then install a new battery. If the battery solution contacts the skin, wash off with water completely.

#### Caution on Remote Controller

- Do not leave the remote controller in an area exposed to direct sunlight, such as on the dashboard or steering wheel. The remote controller may deform because of the heat, (Be especially careful of the dashboard exposed to direct sunlight in the summer, as it will become extremely hot).

## OTHER CONTROLS AND EQUIPMENT

---

- When the vehicle is parked in an area exposed to direct sunlight, Ensure the remote controller is placed in an area not exposed to direct sunlight. For example: Glove box.  
Under direct sunlight, signal reception from the remote controller weakens. If this happens, hold the remote controller close to the signal receptor on the front panel.

Remote Controller (if equipped)

Common operations

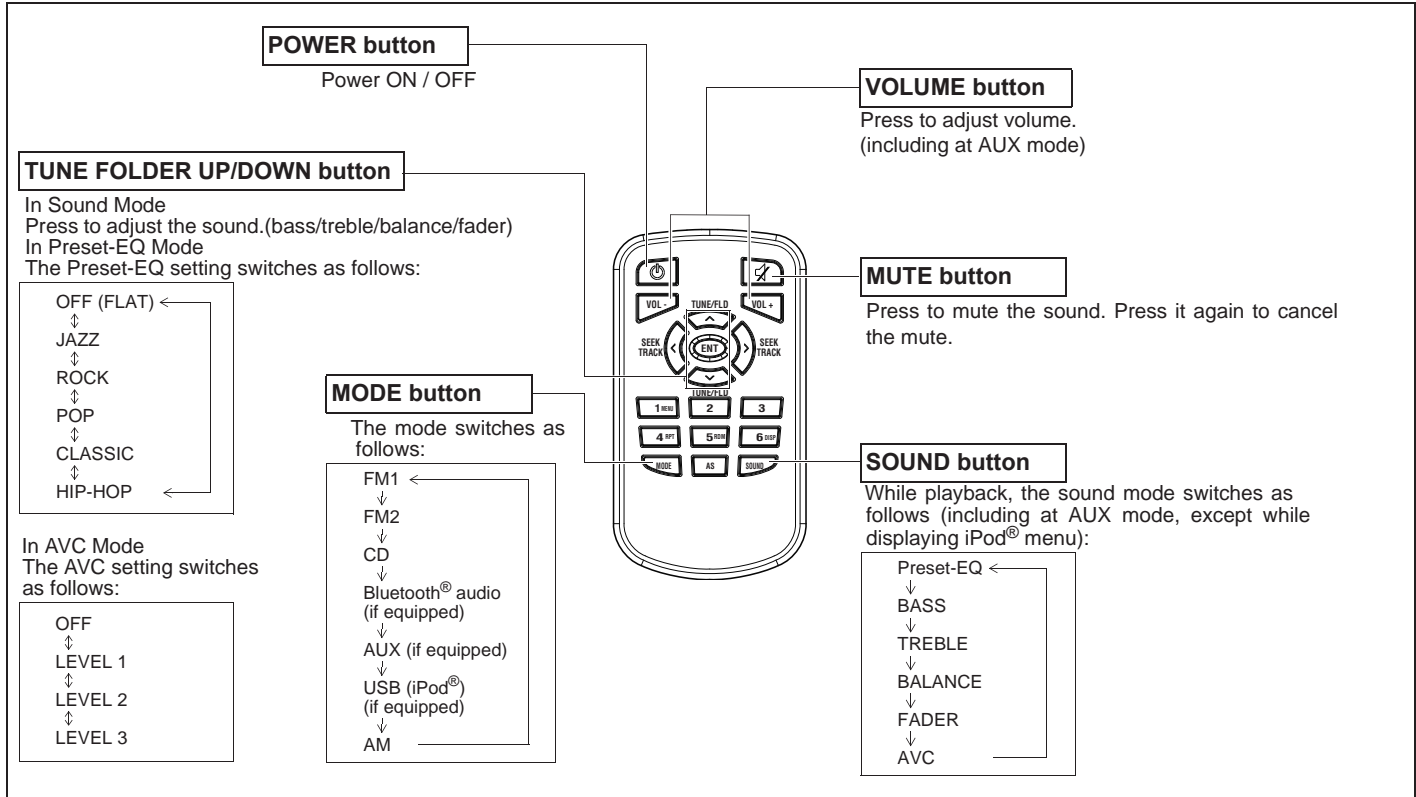

## OTHER CONTROLS AND EQUIPMENT

### Radio operations

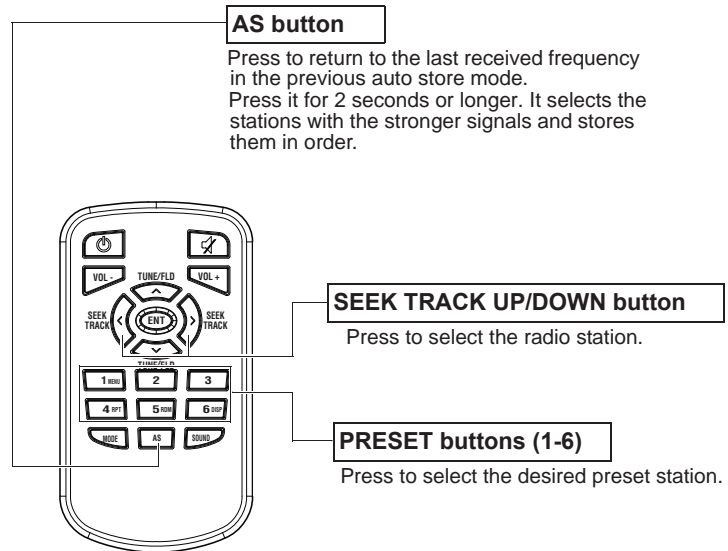

**NOTE:**

*When there are fewer than 6 stations that can be stored even if 1 round of auto store operation is performed, no station will be stored at the remaining preset buttons.*

CD operations

**RDM (5) button**

Press to play the current track randomly.  
Press it again to cancel.

**RPT (4) button**

Press to plays the current track repeatedly.  
Press it again to cancel.

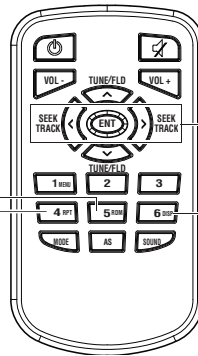

**SEEK TRACK UP/DOWN button**

Press to skip to the next/previous track.  
Press it for 1 second or longer to fast-forward/fast-rewind the track.

**DISP (6) button**

The display switches as follows:

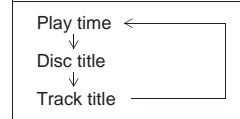

Press it for 1 second or longer to display the next page.

## OTHER CONTROLS AND EQUIPMENT

### MP3/WMA/AAC Disc operations

#### TUNE FOLDER UP/DOWN button

Press to skip to the next/previous folder.

#### RPT (4) button

The repeat mode switches as follows:

OFF  
↓  
FILE REPEAT  
↓  
FOLDER REPEAT

#### RDM (5) button

The random mode switches as follows:

OFF  
↓  
FOLDER RANDOM  
↓  
ALL RANDOM

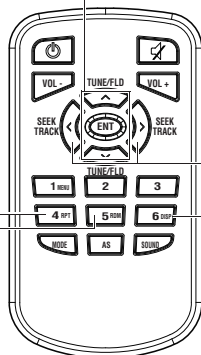

#### SEEK TRACK UP/DOWN button

Press to skip to the next/previous track.  
Press it for 1 second or longer to fast-forward /fast-rewind the track.

#### DISP (6) button

The display switches as follows:

Play time ←  
↓  
Folder name  
↓  
File name  
↓  
Album name (MP3, AAC only)  
↓  
Track title  
↓  
Artist name

Press it for 1 second or longer to display the next page.

## USB operations

### TUNE FOLDER UP/DOWN button

Press to skip to the next/previous folder.

### RPT (4) button

The repeat mode switches as follows:

OFF  
↓  
FILE REPEAT  
↓  
FOLDER REPEAT

### RDM (5) button

The random mode switches as follows:

OFF  
↓  
FOLDER RANDOM  
↓  
ALL RANDOM

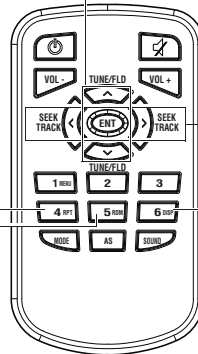

### SEEK TRACK UP/DOWN button

Press to skip to the next/previous file.  
Press it for 1 second or longer to fast-forward/fast-rewind the file.

### DISP (6) button

The display switches as follows:

Play time ←  
↓  
Folder name  
↓  
File name  
↓  
Album name (MP3, AAC only)  
↓  
Track title  
↓  
Artist name

Press it for 1 second or longer to display the next page.

## OTHER CONTROLS AND EQUIPMENT

### iPod® operations

#### ENT button

While displaying iPod® menu, press to select the desired item and display the list. When a track is selected from the list, the playback starts.

#### TUNE FOLDER UP/DOWN button

While displaying iPod® menu, press to display the next/previous list in the same layer.

#### RPT (4) button

Press to play the current track repeatedly. Press it again to cancel.

#### RDM (5) button

The random mode switches as follows:

OFF ←  
↓  
SONG RANDOM  
↓  
ALBUM RANDOM

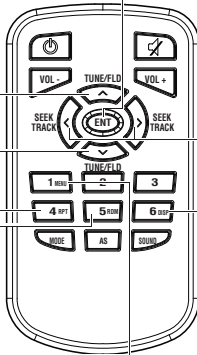

#### SEEK TRACK UP/DOWN button

Press to skip to the next/previous file. Press it for 1 second or longer to fast-forward/fast-rewind the file.

#### DISP (6) button

The display switches as follows:

Playlist name / ←  
Track title (Playlist mode only)  
↓  
Artist name / Track title  
↓  
Album name / Track title  
↓  
Track title / Play time

Press it for 1 second or longer to display the next page.

#### MENU button

During playback

- Press to display iPod® menu.
  - Press it for 1 second or longer to display the top menu.
- While iPod® menu is displayed
- Press to display the folder in one layer upper.
  - Press it for 1 second or longer to display the top menu.



### Troubleshooting

When encountered a problem, check and follow the instructions as described below.

If the described suggestions do not solve the problem, it is recommended to take the unit to your authorised Maruti Suzuki workshop.

Problem	Possible cause	Possible solution
---------	----------------	-------------------

#### Common

Unable to operate	The security function is on.	When "SECURITY" is displayed, enter the ID. When "HELP" is displayed, contact your authorised Maruti Suzuki workshop.
Unable to turn on the power (no sound). (No sound is produced)	Fuse is blown.	Contact your authorised Maruti Suzuki workshop.

#### Radio

Much noise	It may not be exactly tuned in to the station.	Tune it in exactly to the station.
Unable to receive by auto tuning	There may be no station emitting signals powerful enough.	Pick up a station by manual tuning.

#### CD

Sound skips or noise produced	The disc is dirty.	Wipe the disc with a soft cloth.
	The disc has a major scratch or is warped.	Replace the disc with the one with no scratch and also not warped.

## OTHER CONTROLS AND EQUIPMENT

Problem	Possible cause	Possible solution
---------	----------------	-------------------

### MP3/WMA/AAC

No playback	The disc contains unsupported formatted data.	Check the file format.
Sound skips or noise produced	Sound skipping may occur when playing VBR (Variable Bit Rate) files.	It is not recommended to play VBR files.

### USB

Playback does not start when the USB device is connected.	There is no supported format file to play on this unit.	Check the file format.
	The current consumption of the USB device exceeds 1.0 A.	Use an USB device with a current consumption lower than 1.0 A.

### Bluetooth®

Pairing failed	The distance between this unit and the Bluetooth® ready device is too far, or a metallic object may be located between the Bluetooth® ready device and this unit.	Change the location of the Bluetooth® ready device.
	The Bluetooth® function of the Bluetooth® ready device is off.	Refer to the manual of the Bluetooth® ready device. (Some devices have the power saving function that automatically activates after a certain time.)
Unable to receive a call.	Your current location may be out of service area.	Drive your vehicle to the service area of the phone.
The voice quality of hands-free is low (Distortion, noise etc.).	Another wireless device may be located near the unit.	Switch off the wireless device or keep it away from the unit.

**Error Display Messages**

Display	Possible cause	Possible solution
---------	----------------	-------------------

**CD**

<b>ERROR 1</b>	The disc cannot be read.	Insert the disc with its label side up. Check the disc if it is not warped or is free of flaws. When ERROR 1 does not disappear even when a normal disc is inserted, contact your authorised Maruti Suzuki workshop.
<b>ERROR 3</b>	The player developed an error of an unidentified cause.	When the CD is in the unit, press the CD eject button to remove the disc. When the disc cannot be ejected, contact your authorised Maruti Suzuki workshop.

**USB/iPod®**

<b>ERROR 1</b>	The USB device is disconnected.	Check the connection of the USB device.
<b>ERROR 2</b>	Impossible to communicate correctly with the USB device.	Unplug the USB device and plug it again. Check the USB device.
<b>ERROR 3</b>	Inoperable due to an unidentified cause.	Unplug the USB device and plug it again. When ERROR 3 does not disappear, contact your authorised Maruti Suzuki workshop.
<b>ERROR 4</b>	The current consumption of the USB device exceeds 1.0 A.	Check the USB device.

## OTHER CONTROLS AND EQUIPMENT

---

Display	Possible cause	Possible solution
---------	----------------	-------------------

### Bluetooth®

<b>ERROR 1</b>	The player developed an error of an unidentified cause.	Disconnect the Bluetooth® ready device and connect it again. When ERROR 1 does not disappear, contact your authorised Maruti Suzuki workshop.
<b>Failed</b>	Failed to establish pairing	Try to establish the pairing again.
<b>Memory Full</b>	Reached the limit for the number of connected device information	Delete information of unnecessary devices and try to establish the pairing again.
<b>Not Avail.</b>	Inoperable during driving	Operate the system after pulling over your vehicle.
<b>Not Linked</b>	Phone is disconnected	Try to establish the pairing again.

# VEHICLE LOADING AND TOWING

Vehicle Loading ..... 6-1  
Trailer Towing ..... 6-1

# VEHICLE LOADING AND TOWING

## Vehicle Loading

Your vehicle was designed for specific weight capacities. The weight capacities of your vehicle are indicated by the Gross Vehicle Weight Rating (GVWR) and the Permissible maximum Axle Weight (PAW, front and rear). The GVWR and PAW (front and rear) are listed in the "SPECIFICATIONS" section.

GVWR – Maximum permissible overall weight of the fully loaded vehicle (including all the occupants, accessories and cargo plus the trailer nose weight if towing a trailer).

PAW – (Front and Rear) Maximum permissible weight on an individual axle.

Actual weight of the loaded vehicle and actual loads at the front and rear axles can only be determined by weighing the vehicle. Compare these weights to the GVWR and PAW (front and rear). If the gross vehicle weight or the load on either axle exceeds these ratings, you must remove enough weight to bring the load down to the rated capacity.

### WARNING

**Never overload your vehicle. The gross vehicle weight (sum of the weights of the vehicle, all the occupants, accessories, cargo plus trailer nose weight if towing a trailer) must never exceed the Gross Vehicle Weight Rating (GVWR). In addition, never distribute a load so that the weight on either the front or rear axle exceeds the Permissible maximum Axle Weight (PAW).**

### WARNING

**Always distribute cargo evenly. To avoid personal injury or damage to your vehicle, always secure cargo to prevent it from shifting if the vehicle moves suddenly. Place heavier objects on the floor and as far forward in the cargo area as possible. Never pile cargo higher than the top of the seat backs.**

## Trailer Towing

Your vehicle was originally designed to carry people and a normal amount of cargo, not to tow a trailer. MARUTI SUZUKI does not recommend you use your vehicle to tow a trailer. Towing a trailer can adversely affect handling, durability, and fuel economy.

---

## INSPECTION AND MAINTENANCE

Maintenance Schedule .....	7-2
Periodic Maintenance Schedule .....	7-2
Drive Belt .....	7-6
Engine Oil and Filter .....	7-6
Engine Coolant .....	7-9
Air Cleaner .....	7-11
Gear Oil .....	7-11
Clutch Pedal .....	7-13
Fuel Filter .....	7-13
Brakes .....	7-13
Steering .....	7-15
Tires .....	7-16
Battery .....	7-18
Fuses .....	7-20
Headlight Aiming .....	7-24
Bulb Replacement .....	7-24
Wiper Blades .....	7-34
Windshield Washer Fluid .....	7-37
Air Conditioning System .....	7-38



60A187S

### ⚠ WARNING

You should take extreme care when working on your vehicle to prevent accidental injury. Here are a few precautions that you should be especially careful to observe:

- To prevent damage or unintended activation of the air bag system be sure the battery is disconnected and the ignition switch has been in the "LOCK" position for at least 90 seconds before performing any electrical service work on your MARUTI SUZUKI. Do not touch air bag system components, or wires. The wires are wrapped with yellow tape or yellow tubing, and the couplers are yellow for easy identification.
- Do not leave the engine running in garages or other confined areas.

(Continued)

### ⚠ WARNING

(Continued)

- When the engine is running, keep hands, clothing, tools, and other objects away from the fan and drive belt. Even though the fan may not be moving, it can automatically turn on without warning.
- When it is necessary to do service work with the engine running, make sure that the parking brake is set fully and the transaxle is in Neutral.
- Do not touch ignition wires or other ignition system parts when starting the engine or when the engine is running, or you could receive an electric shock.
- Be careful not to touch a hot engine, exhaust manifold and pipes, muffler, radiator and water hoses.
- Do not allow smoking, sparks, or flames around fuel or the battery. Flammable fumes are present.
- Do not get under your vehicle if it is supported only with the portable hack provided in your vehicle.
- Be careful not to cause accidental short circuits between the positive and negative battery terminals.
- Keep used oil, coolant, and other fluids away from children and pets. Dispose of used fluids properly; never pour them on the ground, into sewers, etc.



## Maintenance Schedule

The following table shows the times when you should perform regular maintenance on your vehicle. This table shows in kilometers and months when you should perform inspections, adjustments, lubrication and other services.

### WARNING

**MARUTI SUZUKI recommends that maintenance on your vehicle should be performed by authorised Maruti Suzuki workshop.**

### NOTICE

**Whenever it becomes necessary to replace parts on your vehicle, it is recommended that you use MARUTI genuine replacement parts or their equivalent.**

## Periodic Maintenance Schedule

“A” :Adjust

“C” : Clean

“R” : Replace or Change

“I” : Inspect, clean, adjust, lubricate or replace as necessary

“L” : Lubricate

“T” : Tighten to Specified Torque

“O” : Rotate

### NOTE:

*This table includes services as scheduled up to 80,000 km mileage. Beyond 80,000 km, carry out the same services at the same intervals respectively.*

## INSPECTION AND MAINTENANCE

Interval: This interval should be judged by odometer reading or months, whichever comes first.		FREE INSPECTION			PERIODIC MAINTENANCE AT COST								
		km (x1000)	1	5	10	20	30	40	50	60	70	80	
		months	1	6	12	24	36	48	60	72	84	96	
<b>Engine</b>													
1-1	Engine Coolant (Level, Leakage)	I	I	I	R	I	R	I	R	I	R		
1-2	Engine oil and engine oil filter	-	-	R	R	R	R	R	R	R	R		
1-3	Cooling system hoses and connections (Leakage and Damage)	I	I	I	I	I	I	I	I	I	I		
1-4	Engine Mounting and Manifold Fixing (Noise, Leakage, Damage etc.)	I	I	I	I	I	I	I	I	I	I		
1-5	Exhaust System (Noise, Leakage etc.)	-	I	-	I	-	I	-	I	-	I		
1-6	Exhaust Gas Recirculation Valve	D13A engine		-	-	-	-	C	-	-	C	-	-
<b>FUEL</b>													
2-1.	Air cleaner filter element	Paved-road		Clean after 5,000 KM. Replace after every 40,000 KM.									
		Dusty Condition		Clean after 2,500 KM or as required. Replace after every 40,000 KM. Replace more frequently if dust condition is severe.									
2-2.	Fuel tank cap, fuel lines and connections (Leakage and Damage)	-	I	-	-	-	I	-	-	-	I		
2-3.	Fuel Filter and Water Draining	I	I	I	R	I	R	I	R	I	R		
<b>CLUTCH AND TRANSMISSION</b>													
3-1.	Clutch fluid (level, leakage)	I	I	I	R	I	R	I	R	I	R		
3-2.	Clutch slipping (Dragging or Excess Damage)	I	I	I	I	I	I	I	I	I	I		
3-3.	Manual Transmission/Transfer or Differential Oil (Level, Leakage)	Replace at 1,60,000 km or 10 years whichever comes first											
		I	I	I	I	I	I	I	I	I	I		
<b>DRIVE SHAFT</b>													
4-1.	Drive shaft boot (boot damage)	-	I	I	I	I	I	I	I	I	I		
<b>BRAKE</b>													
5-1.	Brake Fluid (Level, Leakage)	I	I	I	R	I	R	I	R	I	R		
5-2.	Brake pedal (pedal - wall clearance)	I	I	I	I	I	I	I	I	I	I		
5-3.	Parking brake lever and cable (Play, damage)	I	I	I	I	I	I	I	I	I	I		
5-4.	Brake disc and pad (Wear)	-	I	I	I	I	I	I	I	I	I		

## INSPECTION AND MAINTENANCE

Interval: This interval should be judged by odometer reading or months, whichever comes first.		FREE INSPECTION			PERIODIC MAINTENANCE AT COST							
		km (x1000)	1	5	10	20	30	40	50	60	70	80
		months	1	6	12	24	36	48	60	72	84	96
5-5.	Brake drum and shoes (Wear)	-	-	I	I	I	I	I	I	I	I	I
5-6.	Master cylinder and wheel cylinder or caliper, brake hoses and pipes (Fluid leakage, damage)	I	I	I	I	I	I	I	I	I	I	I
5-7.	Master cylinder sub assembly, wheel cylinder boot kit & caliper seal set	I	I	I	I	I	R	I	I	I	I	R
<b>WHEEL</b>												
6-1.	Tyres (air pressure, abnormal wear, crack and rotation)	I	I&O	I&O	I&O	I&O	I&O	I&O	I&O	I&O	I&O	I&O
6-2.	Wheels (Damage)	I	I	I	I	I	I	I	I	I	I	I
6-3.	Front/Rear wheel bearing (Loose, damage)	I	I	I	I	I	I	I	I	I	I	I
<b>FRONT / REAR SUSPENSION</b>												
7-1.	Suspension strut (Oil leakage, damage)	I	I	I	I	I	I	I	I	I	I	I
7-2.	Suspension arms / Knuckle support (Loose, damage)	-	I	I	I	I	I	I	I	I	I	I
7-3.	Rear spring (Damage)	I	I	I	I	I	I	I	I	I	I	I
7-4.	Shock absorbers (Oil leakage, damage)	I	I	I	I	I	I	I	I	I	I	I
7-5.	All bolts and nuts (Loose)	-	T	T	T	T	T	T	T	T	T	T
7-6.	Torsion rods	-	I	I	I	I	I	I	I	I	I	I
<b>STEERING</b>												
8-1.	Steering wheel (Play, loose)	I	I	I	I	I	I	I	I	I	I	I
8-2.	Steering column and tie rods (Loose, damage, wear)	I	I	I	I	I	I	I	I	I	I	I
<b>ELECTRICAL</b>												
9-1.	Battery electrolyte (Level, leakage)	I	I	I	I	I	I	I	I	I	I	I
9-2.	Wiring harness connection (Loose, damage)	-	I	I	I	I	I	I	I	I	I	I
9-3.	Lighting system (Operation, stains, damage)	I	I	I	I	I	I	I	I	I	I	I
9-4.	Horn (Operation)	I	I	I	I	I	I	I	I	I	I	I
9-5.	System Voltage	I	I	I	I	I	I	I	I	I	I	I
<b>BODY</b>												
10-1.	All chassis bolts and nuts (Tighten)	-	I	T	T	T	T	T	T	T	T	T
10-2.	All latches, hinges and locks (Function)	I	I&L	I&L	I&L	I&L	I&L	I&L	I&L	I&L	I&L	I&L

## INSPECTION AND MAINTENANCE

Interval: This interval should be judged by odometer reading or months, whichever comes first.	FREE INSPECTION			PERIODIC MAINTENANCE AT COST							
	km (x1000)	1	5	10	20	30	40	50	60	70	80
	months	1	6	12	24	36	48	60	72	84	96

### ROAD TEST

11-1.	Operation of Brakes, gear shifting and speedometer	I	I	I	I	I	I	I	I	I	I
11-2.	Body and chassis noise	I	I	I	I	I	I	I	I	I	I

### AIR CONDITIONER

12-1.	Check belt tension	I	I	I	I	I	I	I	I	I	I
12-2.	Tighten compressor mounting bolt	-	T	T	T	T	T	T	T	T	T
12-3.	All hose joint (Check, tighten)	I	I	I	I	I	I	I	I	I	I
12-4.	Check functioning of recirculating flap	I	I	I	I	I	I	I	I	I	I
12-5.	Clean condenser with low pressure water	-	C	C	C	C	C	C	C	C	C
12-6.	Check belt for frayed edges	I	I	I	I	I	I	I	I	I	I
12-7.	Check all mounting bolts	I	I	I	I	I	I	I	I	I	I
12-8.	Air conditioner filter element	I	I	I	I	R	I	I	R	I	I

## Drive Belt

 **WARNING**

**When the engine is running, keep hands, hair, clothing, tools, etc. away from the moving fan and drive belts.**

The belts should be examined to ensure that they are not damaged. The drive belt's tension is adjusted automatically.

If you need to replace or adjust the belt have it done by your authorised Maruti Suzuki workshop.

## Engine Oil and Filter

### Specified Oil

#### For D13A Diesel Engine Model

Be sure that the engine oil you use comes under the quality classification of ACEA A5/B5.

SAE **5W-30** is the best choice for good fuel economy, and good starting in cold weather.

#### For D16AA Diesel Engine Model

Be sure that the engine oil you use comes under the quality classification of ACEA C2.

SAE **0W-30** is the best choice for good fuel economy, and good starting in cold weather.

### *NOTICE*

**Use only the recommended engine oil. Use of non-recommended engine oil will cause a damage of the diesel engine.**

## INSPECTION AND MAINTENANCE

### Oil Level Check

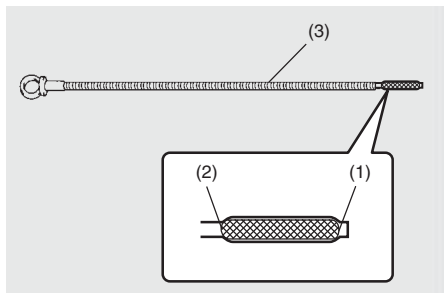

84E012

- (1) MIN
- (2) MAX
- (3) Engine oil dipstick

It is important to keep the engine oil at the correct level for proper lubrication of your vehicle's engine. Check the oil level with the vehicle on a level surface. The oil level indication may be inaccurate if the vehicle is on a slope. The oil level should be checked either before starting the engine or at least 5 minutes after stopping the engine.

The handle of the engine oil dipstick is colored yellow for easy identification.

Pull out the oil dipstick, wipe oil off with a clean cloth, insert the dipstick all the way into the engine, then remove it again. The oil on the stick should be between the upper and lower limits shown on the stick. If the oil level indication is near the lower

limit, add enough oil to raise the level to the upper limit.

#### NOTICE

**Failure to check the oil level regularly could lead to serious engine trouble due to insufficient oil.**

#### NOTICE

**Do not top up the oil over the MAX limit. Too much oil causes serious engine trouble.**

### Refilling

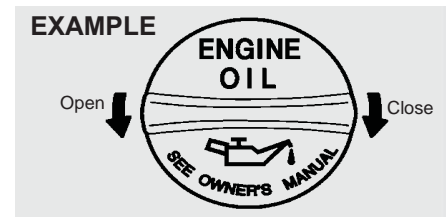

81A147

Remove the oil filler cap and pour oil slowly through the filler hole to bring the oil level to the upper limit on the dipstick. Be careful not to overfill. Too much oil is almost as bad as too little oil. After refilling, start the engine and allow it to idle for about a minute. Stop the engine, wait about 5 minutes and check the oil level again.

## Changing Engine Oil and Filter

Drain the engine oil while the engine is still warm.

### EXAMPLE

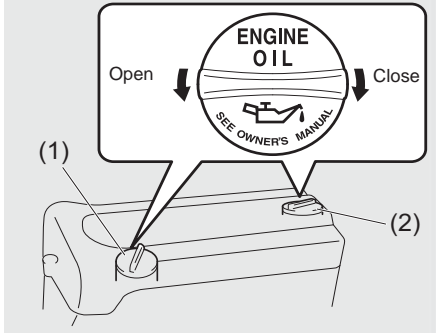

64MS151

- (1) Engine oil filler cap (D13A engine)
- (2) Engine oil filler cap (D16AA engine)

- 1) Remove the oil filler cap.
- 2) Place a drain pan under the drain plug.
- 3) Using a wrench, remove the drain plug and drain out the engine oil.

### **CAUTION**

The engine oil temperature may be high enough to burn your fingers when the drain plug is loosened. Wait until the drain plug is cool enough to touch with your bare hands.

### EXAMPLE

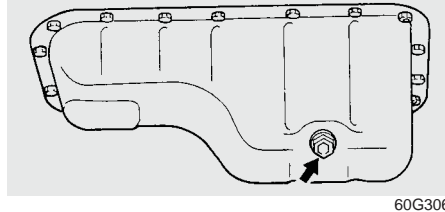

Tightening torque for drain plug  
20 Nm (2.0 kg-m, 14.8 lb-ft)

### **WARNING**

New and used oil can be hazardous. Children and pets may be harmed by swallowing new or used oil. Keep new and used oil and used oil filters away from children and pets.

Repeated, prolonged contact with used engine oil may cause skin cancer. Brief contact with used oil may irritate skin.

To minimize your exposure to used oil, wear a long-sleeve shirt and moisture-proof gloves (such as dish-washing gloves) when changing oil. If oil contacts your skin, wash thoroughly with soap and water.

Launder any clothing or rags if wet with oil. Recycle or properly dispose of used oil and oil filter.

- 4) Reinstall the drain plug with new gasket. Tighten the plug with a wrench to the specified torque.

## Replace the Oil Filter

### For D13A Diesel Engine Model

#### NOTE:

Since special procedures and tools are required, it is recommended that you trust this job to your authorised Maruti Suzuki workshop.

- 1) Using a socket or a ring spanner remove oil filter housing cover (3).

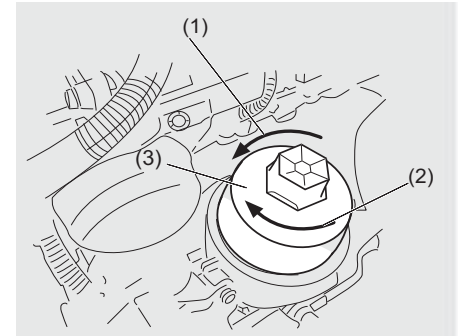

61M7001

- (1) Loosen
- (2) Tighten
- 2) Remove the old oil filter element and replace it with a new oil filter element.
- 3) Clean the surface of oil filter cap and replace the O-ring.
- 4) Tighten the oil filter housing cover on the oil filter housing using a socket or ring spanner to the specified torque.

## INSPECTION AND MAINTENANCE

---

Tightening torque for oil filter  
D13A Diesel engine :  
25 Nm (2.5 kg-m, 18.5 lb-ft)

### NOTICE

To prevent oil leakage, make sure that the oil filter is tight, but do not over-tighten it.

### Refill with Oil and Check for Leaks

- 1) Pour oil through the filler hole and install the filler cap.  
For the approximate capacity of the oil, refer to the "Capacities" item in the "SPECIFICATIONS" section.
- 2) Start the engine and look carefully for leaks at the oil filter and drain plug. Run the engine at various speeds for at least 5 minutes.
- 3) Stop the engine and wait about 5 minutes. Check the oil level again and add oil if necessary. Check for leaks again.

### For D16AA Diesel Engine Model

Since special procedures and tools are required, it is recommended that you trust this job to your authorised Maruti Suzuki workshop.

### NOTICE

- When replacing the oil filter, it is recommended that you use a MARUTI genuine replacement filter. If you use an after market filter, make sure it is of equivalent quality and follow the manufacturer's instructions.
- Oil leaks from around the oil filter or drain plug indicate incorrect installation or gasket damage. If you find any leaks or are not sure that the filter has been properly tightened, have the vehicle inspected by your authorised Maruti Suzuki workshop.

### Engine Coolant

#### Selection of Coolant

To maintain optimum performance and durability of your engine, use MARUTI Genuine Coolant or equivalent.

This type of coolant is best for your cooling system as it:

- Helps maintain proper engine temperature.
- Gives proper protection against freezing and boiling.
- Gives proper protection against corrosion and rust.

*Failure to use the proper coolant can damage your cooling system. Your authorised Maruti Suzuki workshop can help you select the proper coolant.*



**NOTICE**

To avoid damaging your cooling system:

- Always use a high quality ethylene glycol base non-silicate type coolant diluted with distilled water at the correct mixture concentration.
- Make sure that the proper mix is 50/50 coolant to distilled water and in no case higher than 70/30. Concentrations greater than 70/30 coolant to distilled water will cause overheating conditions.
- Do not use straight coolant nor plain water.
- Do not add extra inhibitors or additives. They may not be compatible with your cooling system.
- Do not mix different types of base coolants. Doing so may result in accelerated seal wear and/or the possibility of severe overheating and extensive engine damage.

**Coolant Level Check**

Check the coolant level at the reservoir tank, not at the radiator. With the engine cool, the coolant level should be between the "FULL" and "LOW" marks.

**Adding Coolant****⚠ WARNING**

Engine coolant is harmful or fatal if swallowed or inhaled. Do not drink antifreeze or coolant solution. If swallowed, do not induce vomiting. Immediately contact a poison control center or a physician. Avoid inhaling mist or hot vapors; if inhaled, remove to fresh air. If coolant gets in eyes, flush eyes with water and seek medical attention. Wash thoroughly after handling. Solution can be poisonous to animals. Keep out of the reach of children and animals.

**NOTICE**

- The mixture you use should contain 50% concentration of antifreeze.
- If the lowest ambient temperature in your area is expected to be  $-35^{\circ}\text{C}$  ( $-31^{\circ}\text{F}$ ) or below, use higher concentrations up to 60% following the instructions on the antifreeze container.

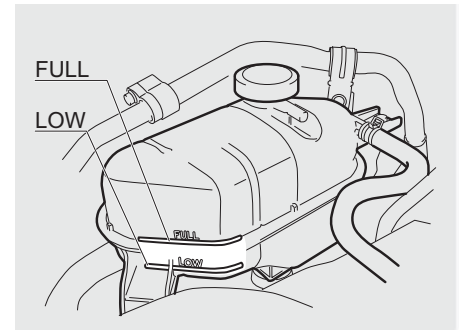

61MM0A125

### **⚠ WARNING**

It is hazardous to remove the reservoir tank cap (degassing tank cap) for a diesel engine when the water temperature is high, because scalding fluid and steam may be blown out under pressure. Wait until the coolant temperature has lowered before removing the cap.

If the coolant level is below the "LOW" mark, more coolant should be added. When the engine is cool, remove the degassing tank cap by turning it anticlockwise slowly to release any pressure. And add coolant until the degassing tank level reaches the "FULL" mark. Never fill the degassing tank above the "FULL" mark.

### **Coolant Replacement**

Since special procedures are required, we recommend you take your vehicle to your authorised Maruti Suzuki workshop for coolant replacement.

### **Air Cleaner**

If the air cleaner is clogged with dust, there will be greater intake resistance, resulting in decreased power output and increased fuel consumption.

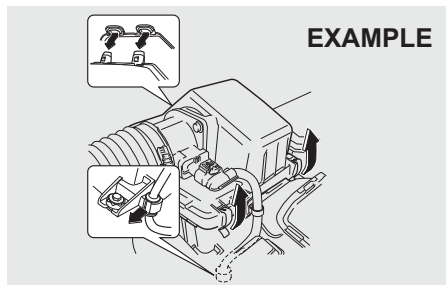

61MM0A126

Unclamp the side clamps and remove the element from the air cleaner case. If it appears to be dirty, replace it with a new one.

Clamp the side clamps securely.

### **Gear Oil**

#### **Manual Transaxle Oil**

When adding gear oil, use gear oil with the appropriate viscosity and grade as shown in the chart below.

We highly recommend you use: "MARUTI GENUINE GEAR OIL 75W-80" for manual transaxle gear oil.

#### **Manual transaxle oil**

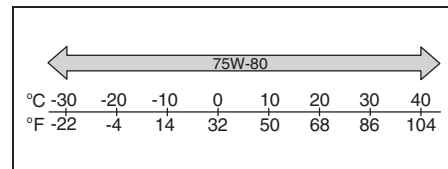

68LM728

#### **Gear Oil Level Check**

##### **5-speed manual transaxle**



52LM021

## 6-speed manual transaxle

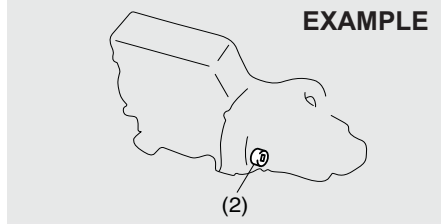

71LS10701

To check the gear oil level, use the following procedure:

- 1) Park the vehicle on a level surface with the parking brake applied. Then, stop the engine.
- 2) Remove the oil filler and level plug.
- 3) If gear oil flows from the plug hole, the oil level is correct. Reinstall the plug. If gear oil does not flow from the plug hole, add oil through the filler plug hole until oil flows a little from the plug hole.

Tightening torque for oil filler and level plug

Manual transaxle (1) or (2):  
21 Nm (2.1 kg-m, 15.5 lb-ft)

**▲ CAUTION**

After driving the vehicle, the gear oil temperature may be high enough to burn you. Wait until the oil filler and level plug is cool enough to touch with your bare hands before inspecting gear oil level.

**NOTICE**

When tightening the plug, apply the following sealing compound or equivalent to the plug threads to prevent oil leakage.

MARUTI SUZUKI Bond No. "1216E" or "1217G"

**Gear Oil Change**

Since special procedures, materials and tools are required, it is recommended that you trust this job to your authorised Maruti Suzuki workshop.

### Clutch Pedal

#### Fluid Control Clutch

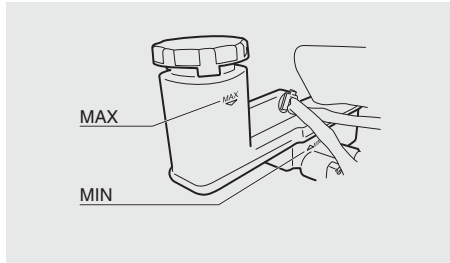

64MS141

Check the clutch pedal for smooth operation and clutch fluid level from time to time. If clutch dragging is felt with the pedal fully depressed, have the clutch inspected by authorised Maruti Suzuki workshop. If the clutch fluid level is near the "MIN" triangle mark, fill it up to the "MAX" triangle mark with MARUTI genuine brake fluid.

### Fuel Filter

#### EXAMPLE

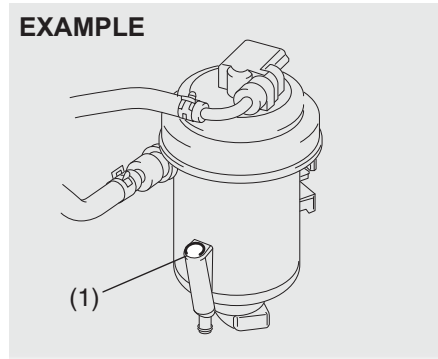

64MS175

The fuel filter works as a water sedimentor as well.

Drain water according to the Periodic Maintenance Schedule. To drain water:

- 1) Place a pan or ample rag under the fuel filter drain nozzle.
- 2) Loosen the drain screw (1). The water will be drained.
- 3) Tighten the drain screw when the water changes to the diesel fuel.

**Tightening torque for drain screw**  
**1.0 Nm (0.10 kg-m, 0.74 lb-ft)**

### Brakes

#### Brake Fluid

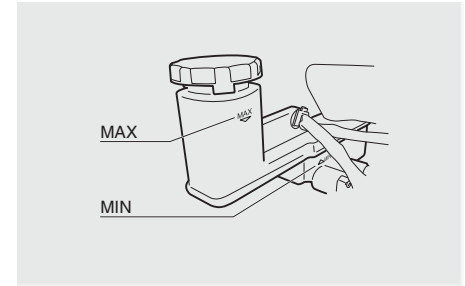

64MS141

Check the brake fluid level by looking at the reservoir in the engine compartment. Check that the fluid level is between the "MAX" and "MIN" triangle mark. If the brake fluid level is near the "MIN" triangle mark, fill it up to the "MAX" triangle mark with MARUTI GENUINE BRAKE FLUID.

**⚠ WARNING**

Failure to follow the guidelines below can result in personal injury or serious damage to the brake system.

- If the brake fluid in the reservoir drops below a certain level, the brake warning light on the instrument panel will come on (the engine must be running with the parking brake fully disengaged). Should the light come on, immediately ask your authorised Maruti Suzuki workshop to inspect the brake system.
- A rapid fluid loss indicates a leak in the brake system which should be inspected by your authorised Maruti Suzuki workshop immediately.
- Do not use any fluid other than MARUTI genuine brake fluid. Do not use reclaimed fluid or fluid that has been stored in old or open containers. It is essential that foreign particles and other liquids are kept out of the brake fluid reservoir.

**⚠ CAUTION**

Brake fluid can harm your eyes and damage painted surfaces. Use caution when refilling the reservoir.

**⚠ WARNING**

Brake fluid is harmful or fatal if swallowed, and harmful if it comes in contact with skin or eyes. If swallowed, do not induce vomiting. Immediately contact a poison control center or a physician. If brake fluid gets in eyes, flush eyes with water and seek medical attention. Wash thoroughly after handling. Solution can be poisonous to animals. Keep out of the reach of children and animals.

**NOTE:**

With disc brakes, the fluid level can be expected to gradually fall as the brake pads wear.

**Brake Pedal**

Check if the brake pedal stops at the regular height without spongy feeling when you depress it. If not, have the brake system inspected by your authorised Maruti Suzuki workshop. If you doubt the brake pedal for the regular height, check it as follows:

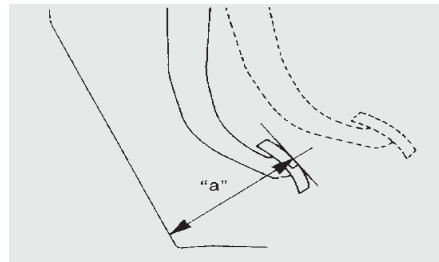

54G108

**Pedal to floor carpet minimum distance "a": 59 mm (2.3 in.)**

With the engine running, measure the distance between the brake pedal and floor carpet when the pedal is depressed with approximately 30 kg (66 lbs) of force. The minimum distance required is as specified. Since your vehicle's brake system is self-adjusting, there is no need for pedal adjustment.

If the pedal to floor carpet distance as measured above is less than the minimum distance required, have your vehicle inspected by your authorised Maruti Suzuki workshop.

**NOTE:**

When measuring the distance between the brake pedal and floor wall, be sure not to include the floor mat or rubber on the floor wall in your measurement.

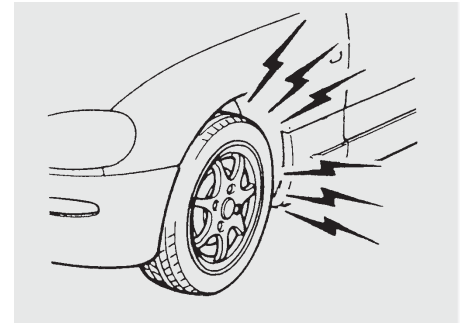

## ⚠ WARNING

If you experience any of the following problems with your vehicle's brake system, have the vehicle inspected immediately by your authorised Maruti Suzuki workshop.

- Poor braking performance
- Uneven braking (brakes not working uniformly on all wheels.)
- Excessive pedal travel
- Brake dragging
- Excessive noise

## Parking Brake

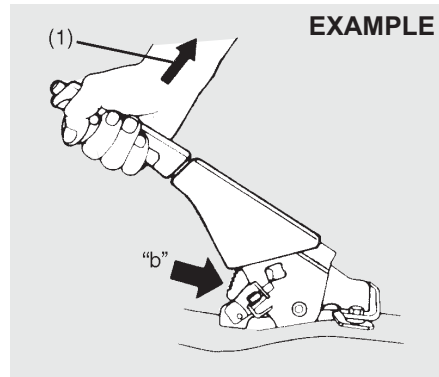

54G109

**Ratchet tooth specification "b":**

**4th – 9th**

**Lever pull force (1):**

**200 N (20 kg, 45 lbs)**

Check the parking brake for proper adjustment by counting the number of clicks made by the ratchet teeth as you slowly pull up on the parking brake lever to the point of full engagement. The parking brake lever should stop between the specified ratchet teeth and the rear wheels should be securely locked. If the parking brake is not properly adjusted or the brakes drag after the lever has been fully released, have the parking brake inspected and/or adjusted by your authorised Maruti Suzuki workshop.

## Steering

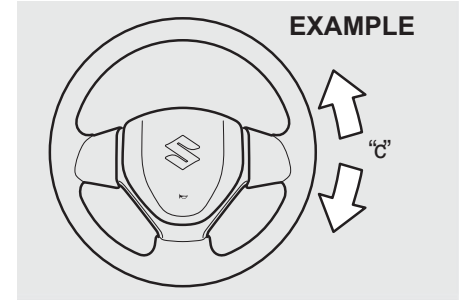

68LM708

**Steering wheel play "c":**  
**0 – 30 mm (0.0 – 1.2 in.)**

Check the play of the steering wheel by gently turning it from left to right and measuring the distance that it moves before you feel slight resistance. The play should be between the specified values.

Check that the steering wheel turns easily and smoothly without rattling by turning it all the way to the right and to the left while driving very slowly in an open area. If the amount of free play is outside the specification or you find anything else to be wrong, an inspection must be performed by your authorised Maruti Suzuki workshop.

## Tires

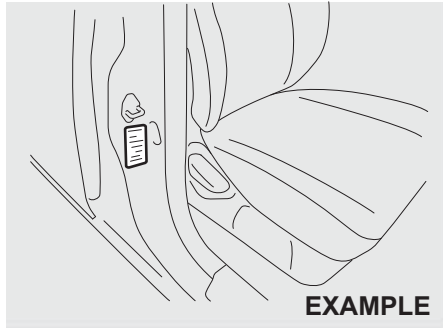

74LHT0704

The front and rear tire pressure specifications for your vehicle are listed on the Tire Information Label. Both the front and rear tires should have the specified tire pressure. Note that the value does not apply to the spare tire, if equipped.

## Tire Inspection

Inspect your vehicle's tires at least once a month by performing the following checks:

- 1) Measure the tire pressure with a tire gauge. Adjust the pressure if necessary. Remember to check the spare tire, too.

**⚠ WARNING**

- **Air pressures should be checked when the tires are cold or you may get inaccurate readings.**
- **Check the inflation pressure from time to time while inflating the tire gradually, until the specified pressure is obtained.**
- **Never under-inflate or over-inflate the tires.**  
**Under inflation can cause unusual handling characteristics or can cause the rim to slip on the tire bead, resulting in an accident or damage to the tire or rim.**  
**Overinflation can cause the tire to burst, resulting in personal injury. Overinflation can also cause unusual handling characteristics which may result in an accident.**

## EXAMPLE

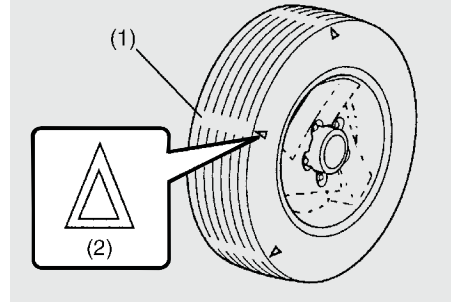

54G136

- 2) Check that the depth of the tread groove is more than 1.6 mm (0.06 in.). To help you check this, the tires have molded-in tread wear indicators in the grooves. When the indicators appear on the tread surface, the remaining depth of the tread is 1.6 mm (0.06 in.) or less and the tire should be replaced.
- 3) Check for abnormal wear, cracks and damage. Any tires with cracks or other damage should be replaced. If any tires show abnormal wear, have them inspected by your authorised Maruti Suzuki workshop.

## INSPECTION AND MAINTENANCE

### ⚠ CAUTION

Hitting curbs and running over rocks can damage tires and affect wheel alignment. Be sure to have tires and wheel alignment checked periodically by your authorised Maruti Suzuki workshop.

- 4) Check for loose wheel nuts.
- 5) Check that there are no nails, stones or other objects sticking into the tires.

### ⚠ WARNING

- Your MARUTI SUZUKI is equipped with tires which are all the same type and size. This is important to ensure proper steering and handling of the vehicle. Never mix tires of different size or type on the four wheels of your vehicle. The size and type of tires used should be only those approved by MARUTI SUZUKI as standard or optional equipment for your vehicle.
- Replacing the wheels and tires equipped on your vehicle with certain combinations of aftermarket wheels and tires can significantly change the steering and handling characteristics of your vehicle.
- Therefore, use only those wheel and tire combinations approved by MARUTI SUZUKI as standard or optional equipment for your vehicle.

### NOTICE

Replacing the original tires with tires of a different size may result in false speedometer or odometer readings. Check with your authorised Maruti Suzuki workshop before purchasing replacement tires that differ in size from the original tires.

## Tire Rotation

### 5-tire rotation

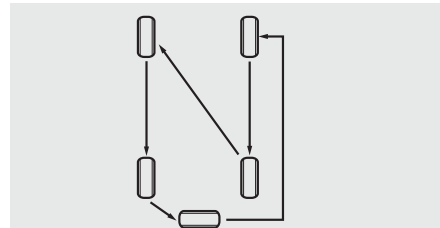

80JK040

If your vehicle is equipped with a spare tire which is a different wheel type than the wheels on the vehicle, you must use a 4-tire rotation as shown in the example below.

### 4-tire rotation

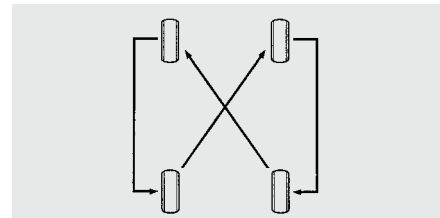

54G114

To avoid uneven wear of your tires and to prolong their life, rotate the tires as illustrated. Tires should be rotated every 10000 km (6000 miles). After rotation, adjust front and rear tire pressures to the specification listed on your vehicle's Tire Information Label.



**Wheel Balancing**

If the vehicle vibrates abnormally on smooth road, have the wheel balanced at authorised Maruti Suzuki workshop .

**Wheel Alignment**

In case of abnormal tyre wear or pulling towards one side, have the wheel aligned at authorised Maruti Suzuki NEXA dealer workshop.

**Tubeless Tyres (If equipped)**

The vehicle is equipped with Tubeless Tyres. In tubeless tyre, a thin layer of butyl rubber is used for lining the inside of the tubeless tyre. This layer is to prevent air loss and fulfilling the purpose of tube. The air pressure is maintained by the sealing between tyre bead and wheel rim. Tubeless tyres are having advantage of slow air loss and preventing sudden deflation while driving.

**Care and maintenance tips for tubeless tyres**

- 1) Always maintain recommended inflation pressure. Driving continuously at low inflation pressure can lead to tyre damage.
- 2) In case any leakage is found, check for any nail penetration/valve core damage or rim bent. Damaged wheel must not be used.
- 3) In case tyre has run at low pressure, it must be inspected for any defect.
- 4) Whenever new tyre is fitted, replace the valve.
- 5) If continuous high speed driving is required, increase tyres pressure by 5 psi over recommended inflation pressure.
- 6) Never run the tyre beyond TWI (Tread wear indicator). The tyre is recommended to be replaced when the remaining tread has worn to this point. The indicators are spaced across the tread around the tyre marked by a triangular symbol (TWI).
- 7) Always prefer tubeless tyre mounting machine. In case of manual mounting-tyre/wheel rim damage may occur.
- 8) In case of any problem, please get in touch with authorised Maruti Suzuki workshop.

**Battery****⚠ WARNING**

- **Batteries produce flammable hydrogen gas. Keep flames and sparks away from the battery or an explosion may occur. Never smoke when working in the vicinity of the battery.**
- **When checking or servicing the battery, disconnect the negative cable. Be careful not to cause a short circuit by allowing metal objects to contact the battery posts and the vehicle at the same time.**
- **To avoid harm to yourself or damage to your vehicle or battery, follow the jump starting instructions in the “EMERGENCY SERVICE” section of this manual if it is necessary to jump start your vehicle.**
- **Diluted sulfuric acid spilled from battery can cause blindness or severe burns. Use proper eye protection and gloves. Flush eyes or body with ample water and get medical care immediately if suffered. Keep batteries out of the reach of children.**

## INSPECTION AND MAINTENANCE

### EXAMPLE

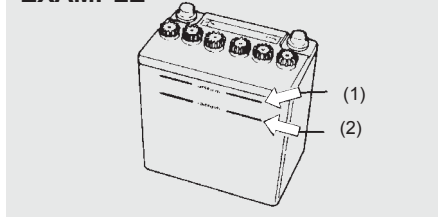

76MS006

The level of the battery solution must be kept between the upper level line (1) and lower level line (2) at all times. If the level is found to be below the lower level line (2), add distilled water to the upper level line (1). You should periodically check the battery, battery terminals, and battery hold-down bracket for corrosion. Remove corrosion using a stiff brush and ammonia mixed with water, or baking soda mixed with water. After removing corrosion, rinse with clean water.

If your vehicle is not going to be driven for a month or longer, disconnect the cable from the negative terminal of the battery to help prevent discharge.

### Replacement of the battery (For D13A Diesel Engine Model)

#### EXAMPLE

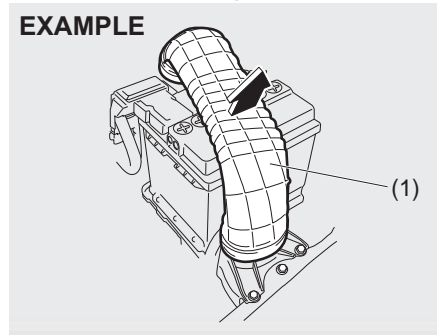

64MS160

**NOTE:**  
(For D13A Diesel Engine Model)  
To approach the battery, remove the suction pipe (1).

### (For D16AA Diesel Engine Model)

#### EXAMPLE

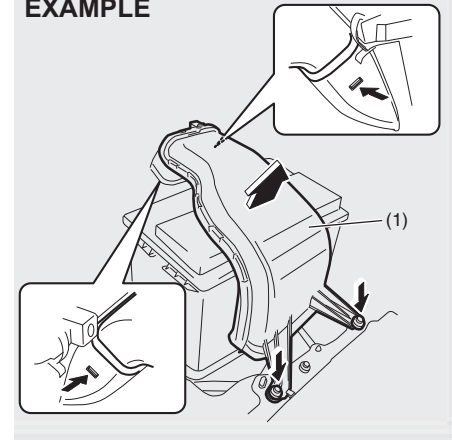

61MS2A006

**NOTE:**  
(For D16AA Diesel Engine Model)  
To approach the battery, loosen the bolts, push the locks and remove the suction pipe (1).

## EXAMPLE

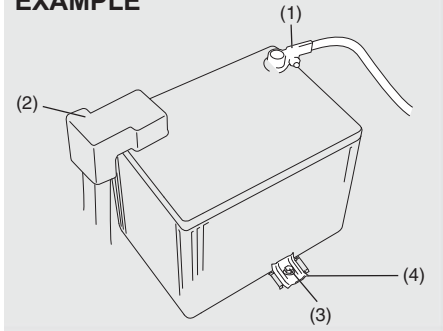

51KM039

To remove the battery:

- 1) Disconnect the negative cable (1).
- 2) Disconnect the positive cable (2).
- 3) Remove the bracket bolt (3) and remove the bracket (4).
- 4) Remove the battery.

To install the battery:

- 1) Install the battery in the reverse order of removal.

## EXAMPLE

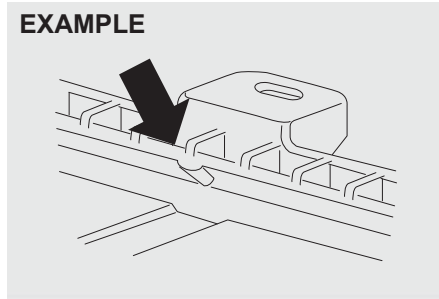

64MS176

### NOTE:

*When putting the battery in the battery tray, make sure the recess on the terminal side bottom of the battery engages with the convex portion of the tray.*

- 2) Tighten the bracket bolt and battery cables securely.

### NOTE:

*When the battery is disconnected, some of the vehicle's function will be initialized and/or deactivated.*

*These function are required to reset after the battery is reconnected.*

## Fuses

Your vehicle has three types of fuses, as described below:

### Main fuse

The main fuse takes current directly from the battery.

### Primary fuses

These fuses are between the main fuse and individual fuses, and are for electrical load groups.

### Individual fuses

These fuses are for individual electrical circuits.

To remove a fuse, use the fuse puller (1) provided in the fuse cover.

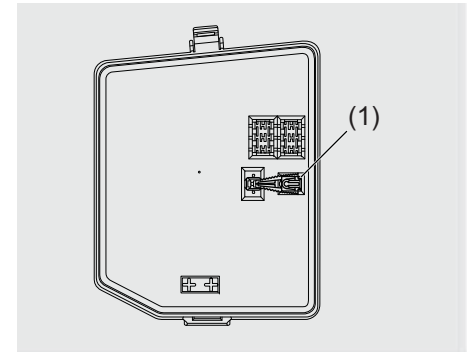

64MS198

## INSPECTION AND MAINTENANCE

### Fuses in the Engine Compartment

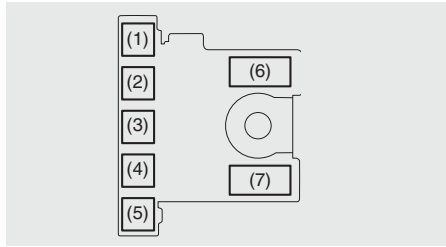

61MM0B068

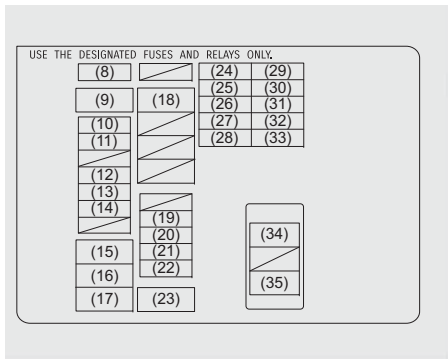

64MS177

MAIN FUSE / PRIMARY FUSE		
(1)	60 A	FL7
(2)	80 A	FL6
(3)	100 A	FL5
(4)	80 A	FL4
(5)	100 A	FL3
(6)	100 A	FL2
(7)	120 A	FL1
(8)	7.5 A	Ignition-1 signal 2 (D16AA)
(9)	30 A	Radiator fan 2
(10)	20 A	Front fog light
(11)	7.5 A	Headlight 2
(12)	25 A	ABS control module
(13)	25 A	Headlight
(14)	30 A	Back up
(15)	40 A	Ignition switch
(16)	40 A	ABS motor
(17)	30 A	Starting motor
(18)	30 A	Radiator fan
(19)	30 A	FI main
(20)	20 A	Fuel pump
(21)	10 A	Air compressor

(22)	7.5 A	ECM (D13A)
(23)	30 A	Blower fan
(24)	10 A	FI 2 (D13A)
(25)	20 A	INJ DRV (D13A)
(26)	7.5 A	Starting signal
(27)	15 A	Headlight (Left)
(28)	15 A	Headlight high (Left)
(29)	7.5 A	FI 2 (D16AA)
(30)	20 A	INJ DRV (D16AA)
(31)	15 A	FI 3 (D16AA)
(32)	15 A	Headlight (Right)
(33)	15 A	Headlight high (Right)
(34)	50 A	Ignition switch 2
(35)	50 A	Battery

The main fuse, primary fuses and some of the individual fuses are located in the engine compartment. If the main fuse blows, no electrical component will function. If a primary fuse blows, no electrical component in the corresponding load group will function. When replacing the main fuse, a primary fuse or an individual fuse, use a Maruti Genuine Part. To remove a fuse, use the fuse puller provided in the fuse box. The amperage of each fuse is shown in the back of the fuse box cover.

EXAMPLE

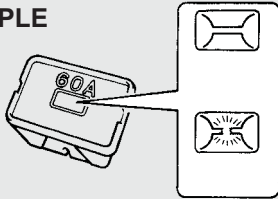

60G111

Fuses under the Dash Board

EXAMPLE

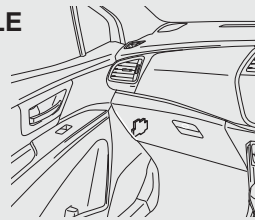

64MS181

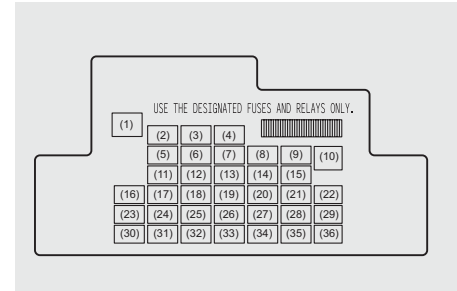

68LM701

**⚠ WARNING**

If the main fuse or a primary fuse blows, be sure to have your vehicle inspected by an authorised Maruti Suzuki workshop. Always use a Maruti Genuine Part. Never use a suitable such as a wire even for a temporary repair, or extensive electrical damage and a fire can result.

NOTE:

Make sure that the fuse box always carries spare fuses.

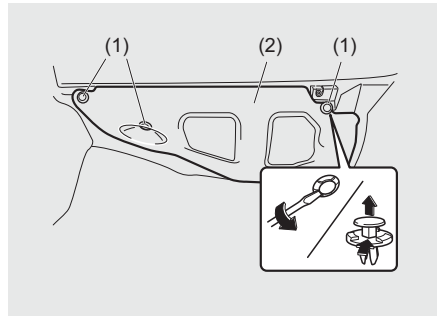

64MS112

NOTE:

To approach the fuses, remove the clips (1) by prying it off with a flat blade screw-driver as shown in the illustration, then remove the cover (2).

## INSPECTION AND MAINTENANCE

PRIMARY FUSE		
(1)	–	Blank
(2)	20 A	Power window timer
(3)	15 A	Steering lock
(4)	20 A	Rear defogger
(5)	20 A	Sunroof*
(6)	10 A	DRL*
(7)	10 A	Heated mirror*
(8)	7.5 A	Starting signal
(9)	15 A	Accessory socket 2
(10)	30 A	Power window
(11)	10 A	Hazard
(12)	7.5 A	BCM
(13)	15 A	Ignition coil
(14)	10 A	ABS control module
(15)	15 A	Accessory socket
(16)	10 A	A-STOP controller*
(17)	15 A	Horn
(18)	10 A	Stop light
(19)	10 A	Air bag
(20)	10 A	Back-up light

(21)	15 A	Wiper / Washer
(22)	30 A	Front wiper
(23)	10 A	Dome light
(24)	15 A	4WD*
(25)	7.5 A	RR fog lamp*
(26)	–	Blank
(27)	7.5 A	Ignition-1 signal
(28)	15 A	Radio 2
(29)	10 A	Accessory socket 3
(30)	15 A	Radio
(31)	10 A	Tail lamp
(32)	20 A	D/L
(33)	7.5 A	Cruise control
(34)	10 A	Meter
(35)	7.5 A	Ignition-2 signal
(36)	20 A	Seat heater*

\*Feature not available in the vehicle.

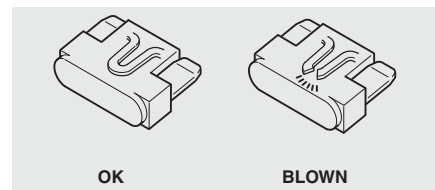

81A283

### WARNING

Always be sure to replace a blown fuse with a fuse of the correct amperage. Never use a substitute such as aluminum foil or wire to replace a blown fuse. If you replace a fuse and the new one blows in a short period of time, you may have a major electrical problem. Have your vehicle inspected immediately by your authorised Maruti Suzuki workshop.

## Headlight Aiming

Since special procedures are required, we recommend you take your vehicle to your authorised Maruti Suzuki workshop for headlight alignment.

## Bulb Replacement

### ⚠ CAUTION

- Light bulbs can be hot enough to burn your finger right after being turned off. This is true especially for halogen headlight bulbs. Replace the bulbs after they become cool enough.
- The headlight bulbs are filled with pressurized halogen gas. They can burst and injure you if they are hit or dropped. Handle them carefully.
- To avoid injury by sharp-edged parts of the body, wear gloves and a long-sleeved shirt when replacing light bulbs.

### NOTICE

The oils from your skin may cause a halogen bulb to overheat and burst when the lights are on. Grasp a new bulb with a clean cloth.

### NOTICE

Frequent replacement of a bulb indicates the need for an inspection of the electrical system. This should be carried out by your authorised Maruti Suzuki workshop.

## Headlights

### Discharge headlights

Since special procedures are required, we recommend you take your vehicle to your authorised Maruti Suzuki workshop for bulb replacement.

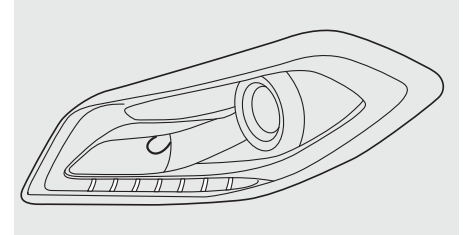

61MM0A031

### ⚠ WARNING

Never attempt to replace the bulb of a discharge headlight, or you could suffer an electric shock from the high-voltage circuit in the headlight system. Always have a discharge headlight bulb replaced by an authorised Maruti Suzuki workshop.

## INSPECTION AND MAINTENANCE

### Halogen headlights (1)

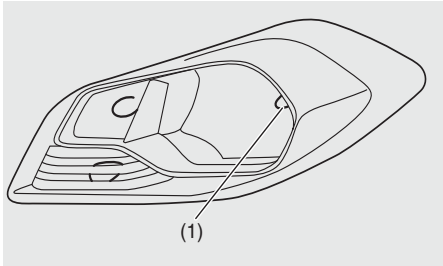

61MM0B073

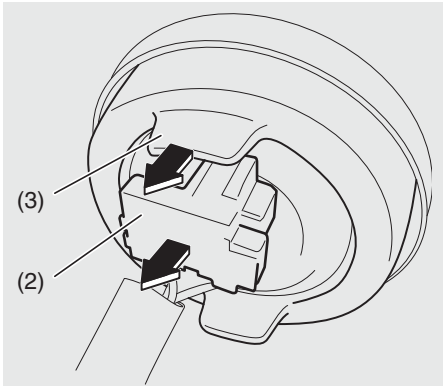

61MM0B074

- 1) Open the engine hood. Disconnect the coupler (2). Remove the sealing rubber (3).

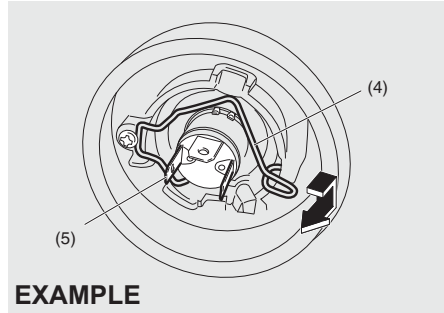

**EXAMPLE**

64MS161

- 2) Push the retaining spring (4) forward and unhook it. Then remove the bulb (5). Install a new bulb in the reverse order of removal.

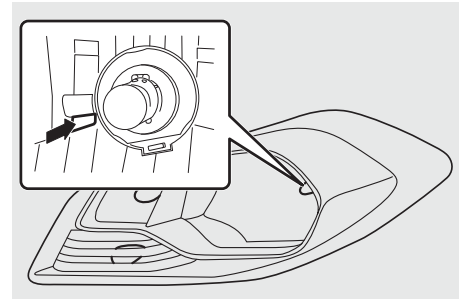

64MS162

#### **NOTE:**

*You can see the position of retaining spring from the hole of headlight.*



## Side Turn Signal Light (if equipped)

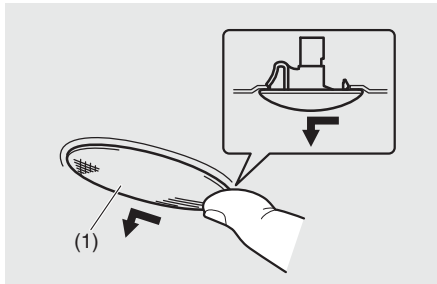

76MH0A006

- 1) Remove the light housing (1) by sliding to left with your finger.

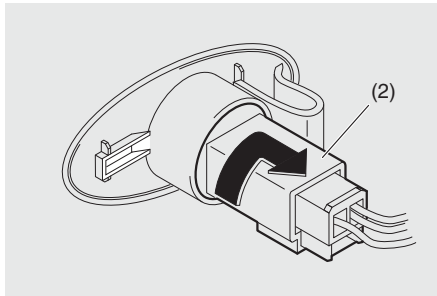

76MH0A007

- 2) Turn the bulb holder (2) clockwise and pull it out from the light housing.

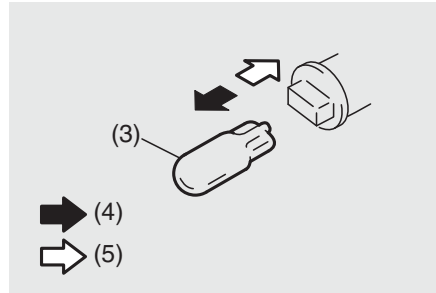

76MH0A008

- (4) Removal
  - (5) Install
- 3) To remove and install the bulb of the turn signal light (3), simply pull out or push in the bulb.

## Front Turn Signal Light (1) Front Position Light (2)

(Vehicle with the halogen headlights)

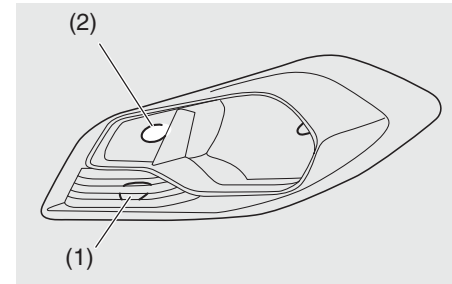

61MM0A030

## INSPECTION AND MAINTENANCE

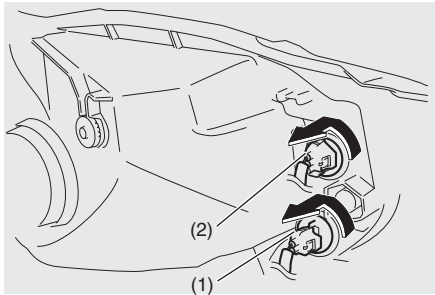

61MM0B077

- 1) Open the engine hood. To remove the bulb holder of the front turn signal light (1) or the front position light (2) from the light housing, turn the holder counterclockwise and pull it out.

### EXAMPLE

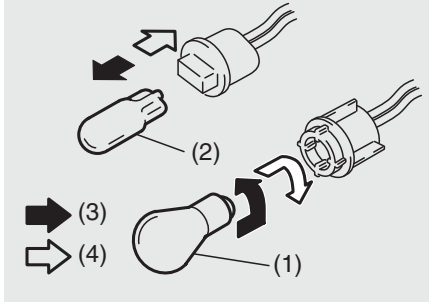

61MM0B078

- (3) Removal
  - (4) Install
- 2) To remove the bulb of the front turn signal light (1) from the bulb holder, push in the bulb and turn it counterclockwise. To install a new bulb, push it in and turn it clockwise.  
To remove and install the bulb of the front position light (2), simply pull out or push in the bulb.

### (Vehicle with the discharge headlights)

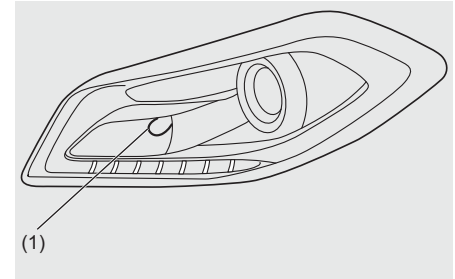

61MM0A091

To replace the bulb of the front turn signal light (1), follow the procedure for the front turn signal light bulb replacement of the vehicle with the halogen headlights.

#### NOTE:

*Position function in discharge headlamp is LED type, which is non replaceable.*

**Front Fog Light (if equipped)**

- 1) Start the engine. Turn the steering wheel to rotate the tires to the opposite side of the fog light that requires replacement. Then turn off the engine.

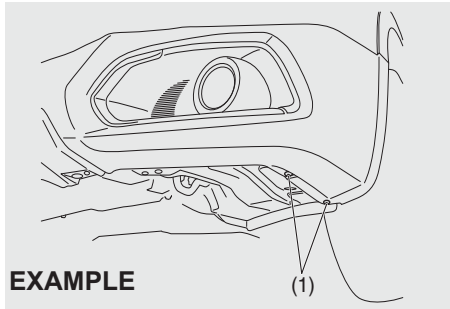

61MM0B079

- 2) Remove the screws (1).

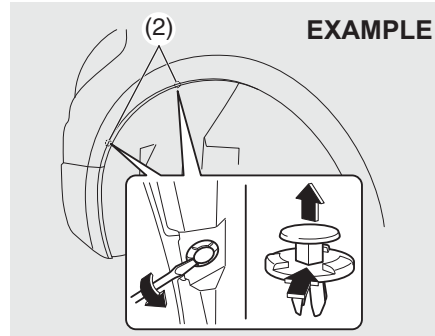

61MM0B080

- 3) Remove the clips (2) by prying it off with a flat blade screwdriver as shown in the illustration.

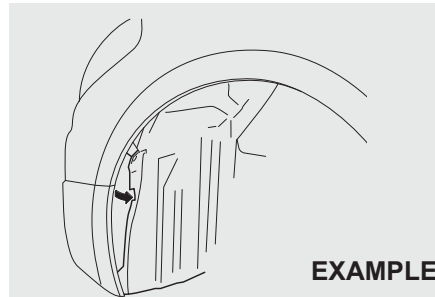

61MM0B081

- 4) Open the end of the cover inside the fender.

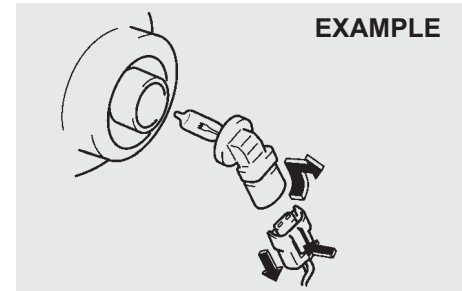

80JM071

- 5) Disconnect the coupler by pushing the lock release. Turn the bulb holder counterclockwise and remove it.

## INSPECTION AND MAINTENANCE

### Rear Combination Light

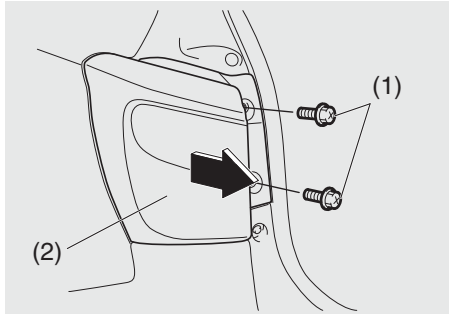

61MM0B082

- 1) Remove the bolts (1) and pull the light housing (2) straight.

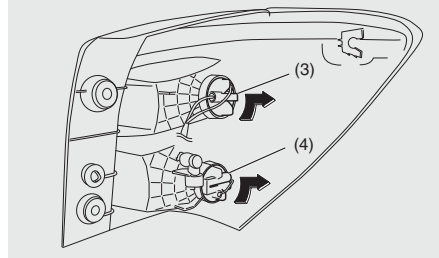

61MM0B083

- 2) To remove the bulb holder of the rear turn signal light (3) or the tail/brake light (4) from the light housing, turn the holder counterclockwise and pull it out.

### EXAMPLE

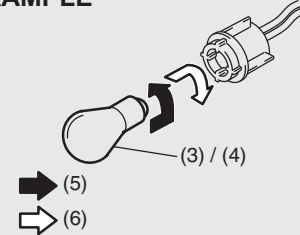

61MM0B084

- (5) Removal  
(6) Install
- 3) To remove the bulb of the rear turn signal light (3) or the tail/brake light (4) from bulb holder, push in the bulb and turn it counterclockwise. To install a new bulb, push it in and turn it clockwise.

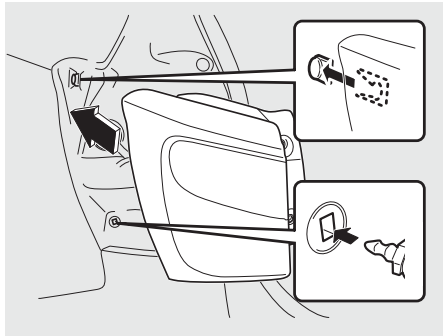

61MM0B085

**NOTE:**  
When reinstalling the light housing, make sure the clips are properly attached.

## Reversing Light

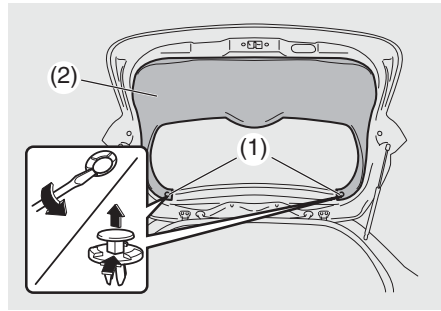

61MM0B088

- 1) Open the tailgate. Remove the clips (1) by prying it off with a flat blade screwdriver as shown in the illustration. Then, pull out the trim (2).

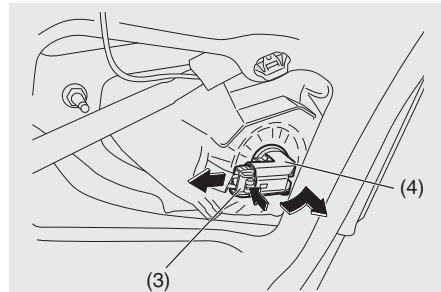

61MM0B089

- 2) Disconnect the coupler (3) by pushing the lock release. Turn the bulb holder of

the reversing light (4) counterclockwise and remove it.

## EXAMPLE

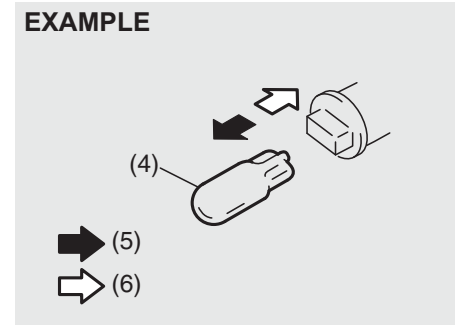

61MM0B090

- (5) Removal
- (6) Install

- 3) To remove and install the bulb of the reversing light (4), simply pull out or push in the bulb.

## INSPECTION AND MAINTENANCE

### License Plate Light

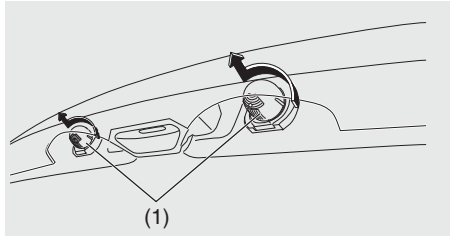

61MM0B086

- 1) Turn the cover (1) counterclockwise to remove it.

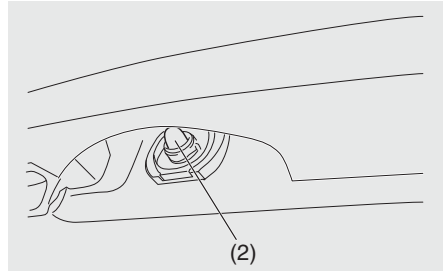

61MM0B087

- 2) To remove and install the bulb of the license plate light (2), simply pull out or push in the bulb.

### High-mount Stop Light

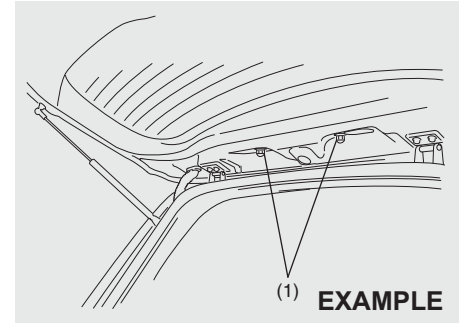

80J100

- 1) Open the tailgate, and remove the nuts (1) as shown in the illustration.

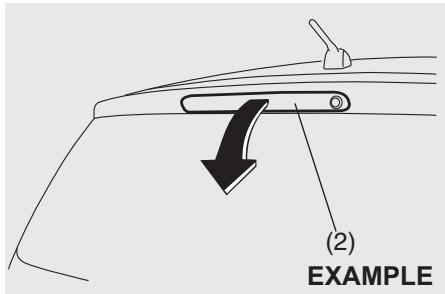

**EXAMPLE**

63J127

- 2) Close the tailgate. Remove the high-mount stop light housing (2) from the tailgate.

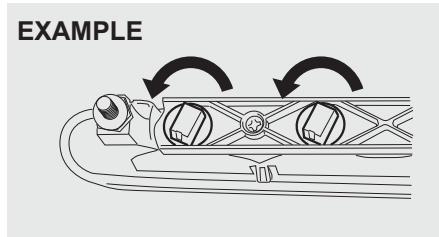

**EXAMPLE**

68KS063

- 3) Remove the bulb holder as shown in the illustration.

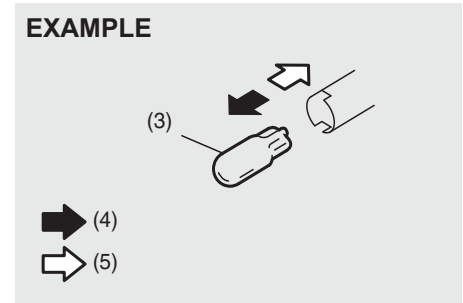

**EXAMPLE**

76MH0A128

- (4) Removal
- (5) Install

- 4) To remove and install the bulb of the high-mount stop light (3), simply pull out or push in the bulb.

## INSPECTION AND MAINTENANCE

### Interior Light

Remove the lens by using a flat blade screwdriver covered with a soft cloth as shown. To install it, simply push it back in.

#### Front (without overhead console)

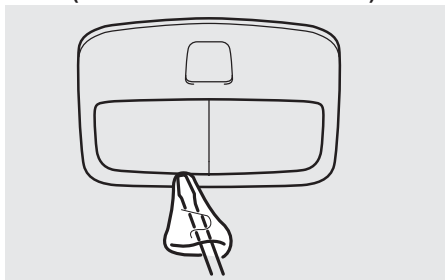

61MM0A207

#### Front (with overhead console)

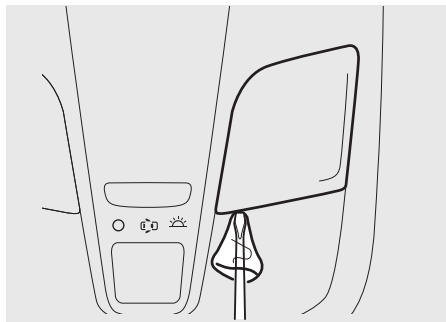

64MS123

#### Luggage compartment (if equipped)

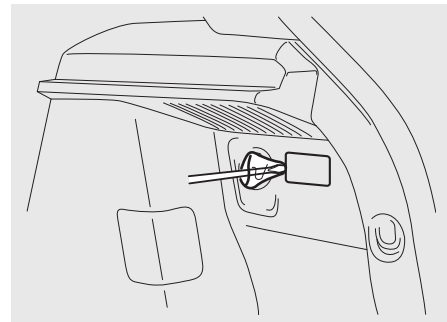

61MM0B072

#### Center

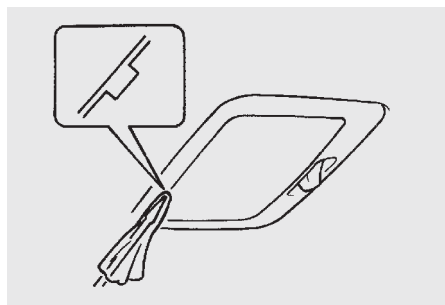

60G115



### Glove Box Light (if equipped)

Since special procedures are required, we recommend you take your vehicle to your authorised Maruti Suzuki workshop for bulb replacement.

#### EXAMPLE

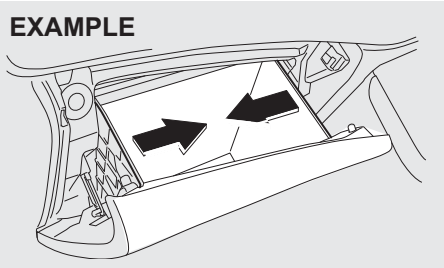

61M0108

- 1) Press inward on both side of the glove box to unclamp it.

#### EXAMPLE

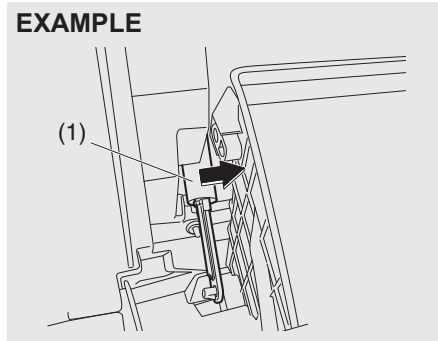

61M0109

- 2) Push the damper (1) (if equipped) rightward to remove the glove box.

#### EXAMPLE

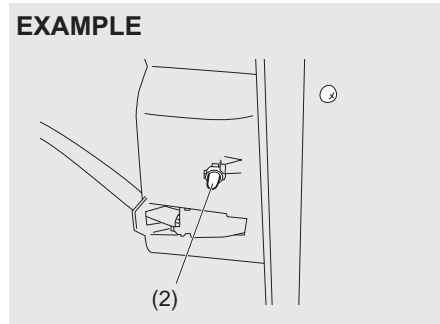

64MS096

- 3) To remove and install the bulb of the glove box light (2), simply pull out or push in the bulb.

### Wiper Blades

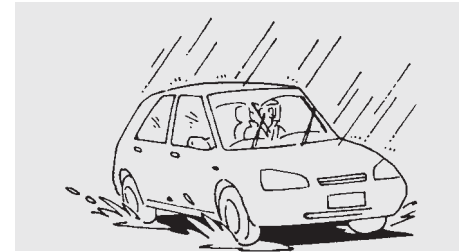

54G129

If the wiper blades become brittle or damaged, or make streaks when wiping, replace the wiper blades.

To install new wiper blades, follow the procedures below.

#### NOTICE

**To avoid scratching or breaking the window, do not let the wiper arm strike the window while replacing the wiper blade.**

#### NOTE:

Some wiper blades may be different from the ones described here depending on vehicle specifications. If so, consult your authorised Maruti Suzuki workshop for proper replacement method.

## INSPECTION AND MAINTENANCE

For windshield wipers:

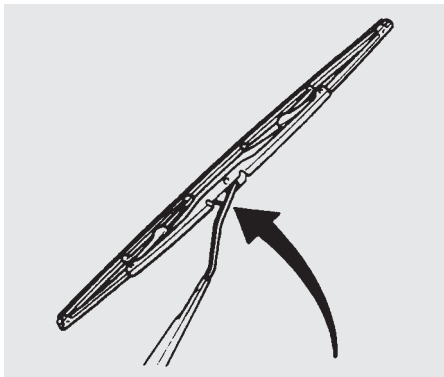

70G119

- 1) Hold the wiper arm away from the window.

### NOTE:

When raising both of the front wiper arms, pull the driver's side wiper arm up first. When returning the wiper arms, lower the passenger's side wiper arm first. Otherwise, the wiper arms may interfere with each other.

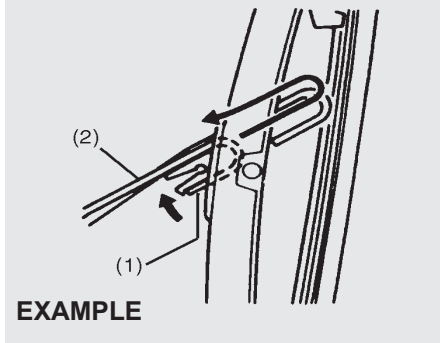
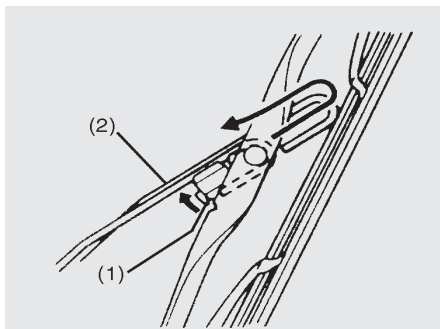

54G130

- 2) Squeeze lock (1) towards wiper arm (2) and remove the wiper frame from the arm as shown.
- 3) Unlock the lock end of the wiper blade and slide the blade out as shown.

Removal

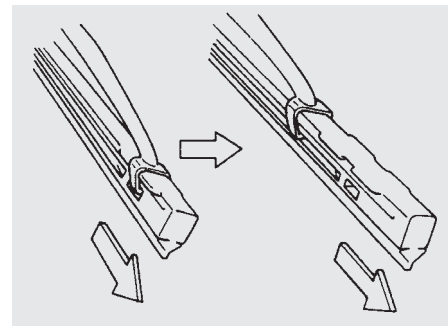

60A260

Installation

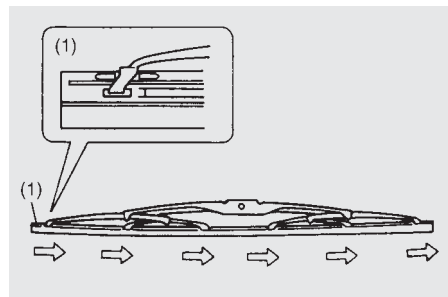

54G132

- (1) Locked end

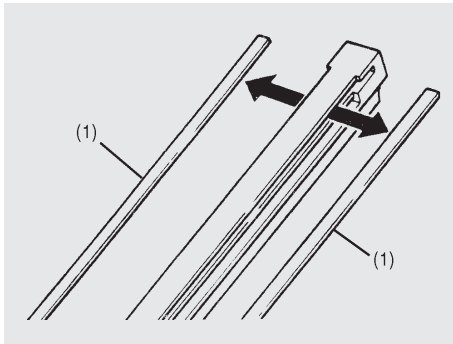

54G135

(1) Retainer

- 4) If the new blade is provided without the two metal retainers, move them from the old blade to the new one.

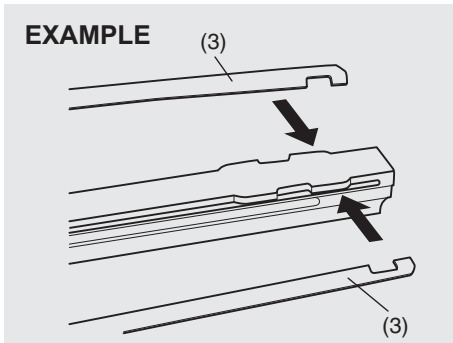

60MH071

## EXAMPLE

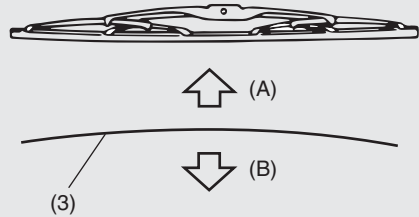

60MH072

- (A) Up  
(B) Down

### NOTE:

When you install the metal retainers (3), make sure the direction of metal retainers as shown in the above illustrations.

- 5) Install the new blade in the reverse order of removal, with the locked end positioned toward the wiper arm. Make sure the blade is properly retained by all the hooks. Lock the blade end into place.
- 6) Reinstall wiper frame to arm, making sure that the lock lever is snapped securely into the arm.

For rear wipers:

## EXAMPLE

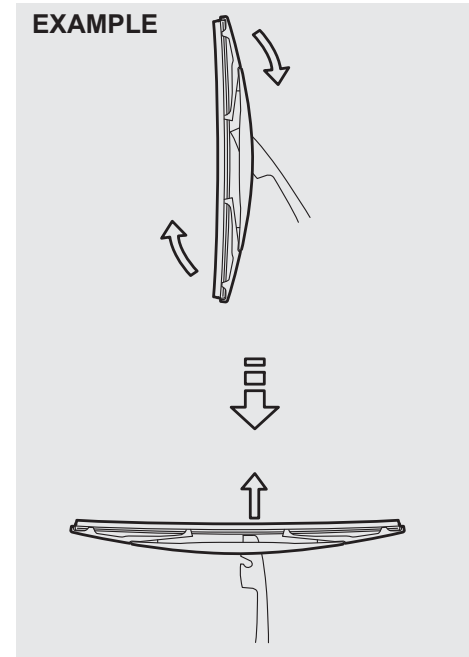

80G146

- 1) Hold the wiper arm away from the window.
- 2) Remove the wiper frame from the arm as shown.
- 3) Slide the blade out as shown.

## INSPECTION AND MAINTENANCE

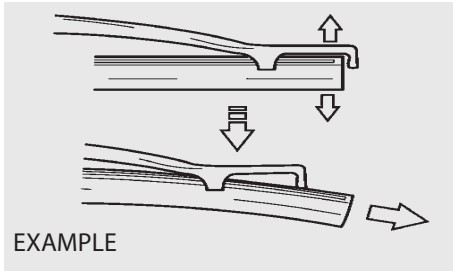

65D151

### NOTE:

Do not flex the wiper blade frame end more than necessary. If you do, it can break off.

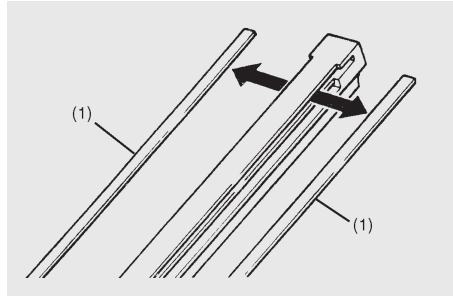

54G135

(1) Retainer

- 4) If the new blade is provided without the two metal retainers, move them from the old blade to the new one.
- 5) Install the new blade in the reverse order of removal.

- Make sure the blade is properly retained by all the hooks.
- 6) Reinstall wiper frame to arm in the reverse order of removal.

### Windshield Washer Fluid

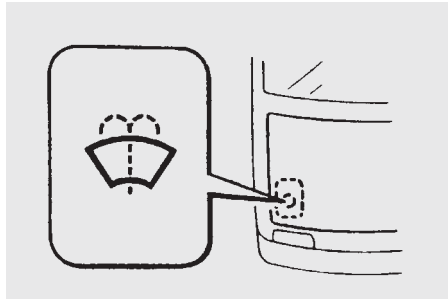

### EXAMPLE

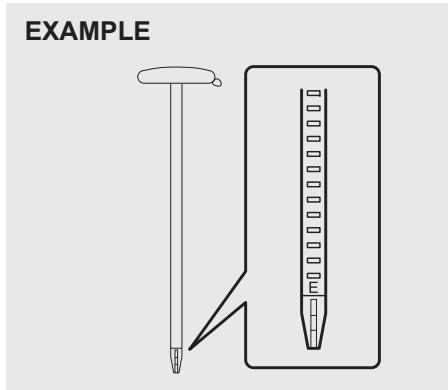

64MS097

Check that there is washer fluid in the tank by looking at the washer fluid level gauge which is attached to the cap of the washer fluid tank. If the fluid level is near empty, refill it. Use a good quality windshield washer fluid, diluted with water as necessary.

### ⚠ WARNING

Do not use radiator antifreeze in the windshield washer reservoir. This can severely impair visibility when sprayed on the windshield, and also damage your vehicle's paint.

### NOTICE

Damage may result if the washer motor is operated with no fluid in the washer tank.

## Air Conditioning System

If you do not use the air conditioner for a long period, such as during winter, it may not give the best performance when you start using it again. To help maintain optimum performance and durability of your air conditioner, it needs to be run periodically. Operate the air conditioner at least once a month for one minute with the engine idling. This circulates the refrigerant and oil and helps protect the internal components.

### Replacement of the Air Conditioner Filter (if equipped)

Since special procedures are required, we recommend you take your vehicle to your authorised Maruti Suzuki workshop for the air conditioner filter replacement.

- 1) To access the air conditioner filter, remove the glove box. Refer to the procedure for the bulb replacement of the "Glove Box Light" in this section.

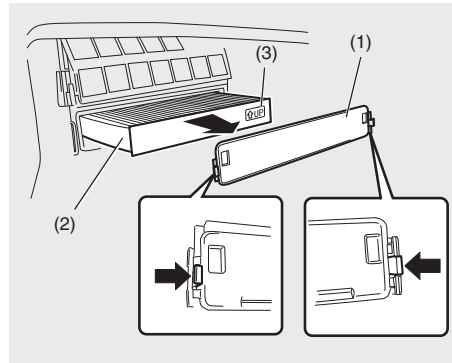

79MH0761

- 2) Remove the cover (1) and pull out the air conditioner filter (2).

#### NOTE:

*When you install a new filter, make sure the UP mark (3) faces upward.*

**MEMO**

-----  
-----  
-----  
-----  
-----  
-----  
-----  
-----  
-----  
-----  
-----  
-----  
-----  
-----  
-----

# EMERGENCY SERVICE

- Tire Changing Tool ..... 8-1
- Jacking Instructions ..... 8-2
- Jump Starting Instructions ..... 8-5
- Towing ..... 8-6
- If the Starter Does Not Operate ..... 8-7
- If the Engine is Flooded ..... 8-7
- If the Engine Overheats ..... 8-7
- Warning Triangle..... 8-8

## EMERGENCY SERVICE

### Tire Changing Tool

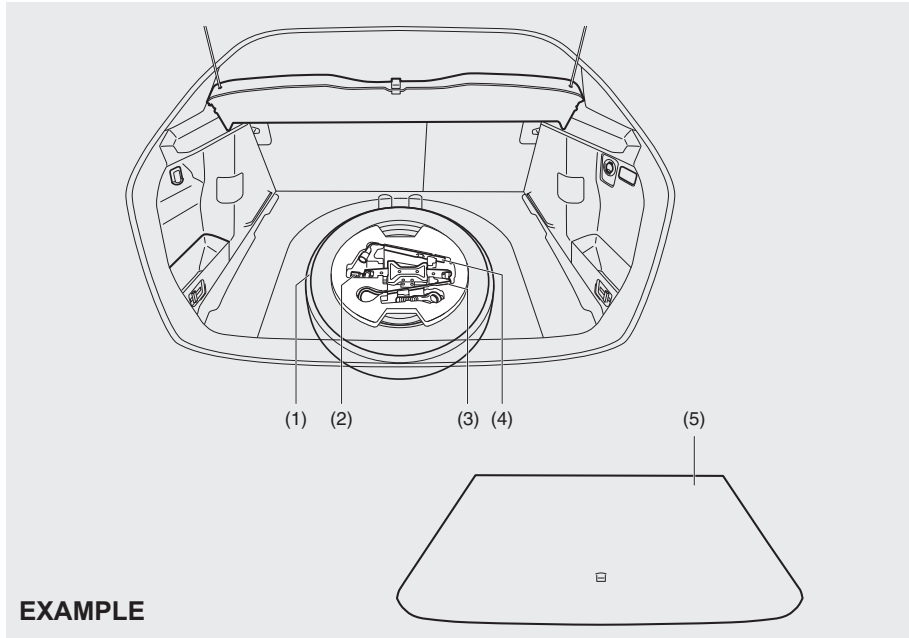

61MM0B100

- (1) Spare tire
- (2) Jack
- (3) Jack handle
- (4) Wheel Brace
- (5) Luggage Compartment Board

The tire changing tools are stowed in the luggage compartment.

#### **⚠ WARNING**

After using the tire changing tools, be sure to stow them securely or they can cause injury if an accident occurs.

#### **⚠ CAUTION**

The jack should be used only to change wheels. It is important to read the jacking instructions in this section before attempting to use the jack.

#### **EXAMPLE**

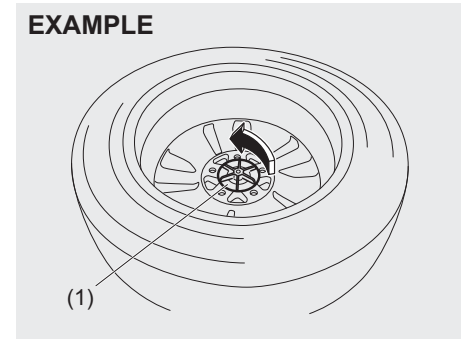

64MS142

To remove the spare tire, turn its bolt (1) counterclockwise and remove it.



## Jacking Instructions

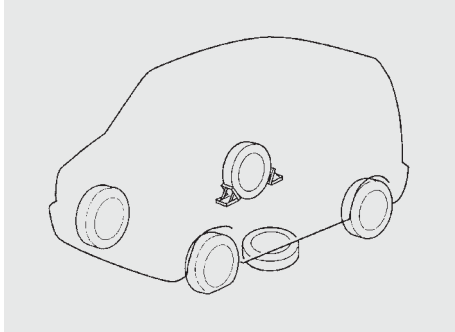

75F062

- 1) Place the vehicle on level, hard ground.
- 2) Set the parking brake firmly and shift into "R" (Reverse).

### ⚠ WARNING

- Be sure to shift into "R" (Reverse) when you jack up the vehicle.
- Never jack up the vehicle with the transaxle in "N" (Neutral). Otherwise, unstable jack may cause an accident.

- 3) Turn on the hazard warning flasher if your vehicle is near traffic.
- 4) Block the front and rear of the wheel diagonally opposite of the wheel being lifted.

- 5) Place the spare wheel near the wheel being lifted as shown in the illustration in case that the jack slips.

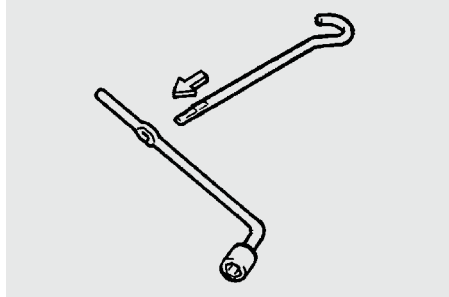

54G253

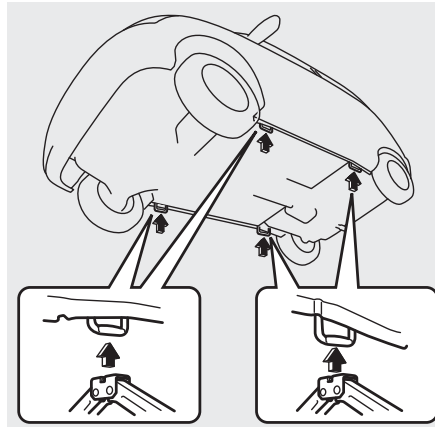

63J100

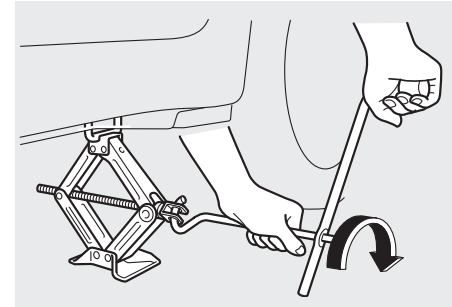

63J101

- 6) Position the jack at an angle as shown in the illustration and raise the jack by turning the jack handle clockwise until the jack-head groove fits around the jacking bar beneath the vehicle body.
- 7) Continue to raise the jack slowly and smoothly until the tire clears the ground. Do not raise the vehicle more than necessary.

### **⚠ WARNING**

- Use the jack only to change wheels on level, hard ground.
- Never jack up the vehicle on an inclined surface.
- Never raise the vehicle with the jack in a location other than the specified jacking point (shown in the illustration) near the wheel to be changed.
- Make sure that the jack is raised at least 25 mm (1 inch) before it contacts the flange. Use of the jack when it is within 25 mm (1 inch) of being fully collapsed may result in failure of the jack.
- Never get under the vehicle when it is supported by the jack.
- Never run the engine when the vehicle is supported by the jack and never allow passengers to remain in the vehicle.

### To Raise the Vehicle with a Garage Jack

- Apply the garage jack to one of the points indicated below.
- Always support the raised vehicle with jack stands (commercially available) at the points indicated below.

#### Front jacking point for garage jack (1)

##### EXAMPLE

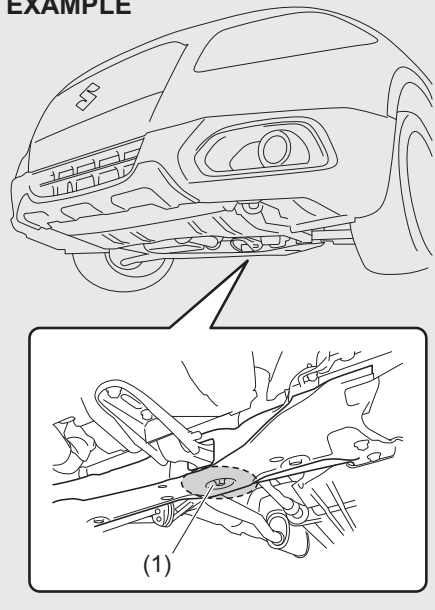

#### Rear jacking point for garage jack (2)

##### EXAMPLE

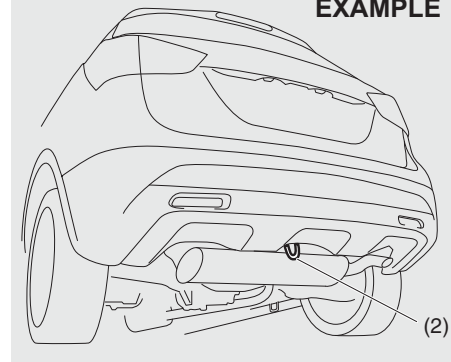

#### Application point for jack stand (3) or two-column lift

##### EXAMPLE

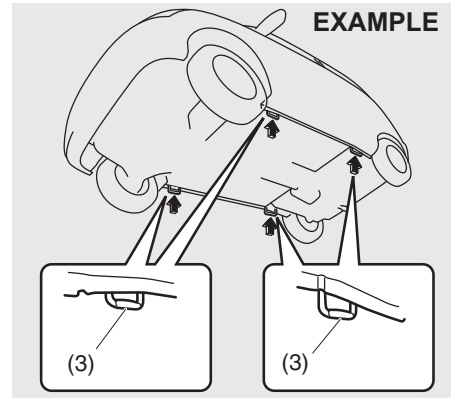

**NOTICE**

Never apply a garage jack to the exhaust pipe, side under spoiler (if equipped), engine undercover or rear torsion beam.

**NOTE:**

For more details, please contact an authorised Maruti Suzuki workshop.

**Changing Wheels**

To change a wheel, use the following procedure:

- 1) Remove the jack, tools and spare wheel from the vehicle.
- 2) Loosen, but do not remove the wheel nuts.
- 3) Jack up the vehicle (follow the jacking instructions in this section).

**⚠ WARNING**

- Be sure to shift into "R" (Reverse) when you jack up the vehicle.
- Never jack up the vehicle with the transaxle in "N" (Neutral). Otherwise, unstable jack may cause an accident.

- 4) Remove the wheel nuts and wheel.

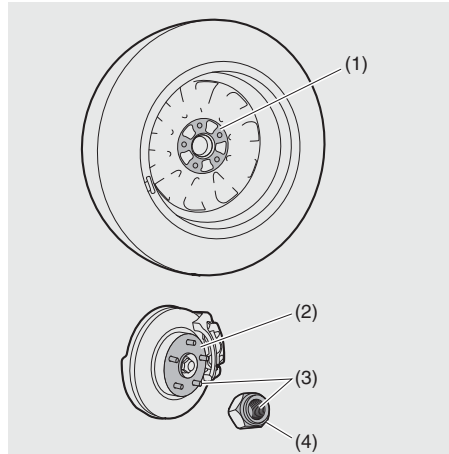

65J4033

- 5) Before installing the new wheel, clean any mud or dirt off from the surface of the wheel (1), hub (2), thread part (3) and surface of the wheel nuts (4) with a clean cloth. Clean the hub carefully; it may be hot from driving.
- 6) Install the new wheel and replace the wheel nuts with their cone shaped end facing the wheel. Tighten each nut snugly by hand until the wheel is securely seated on the hub.

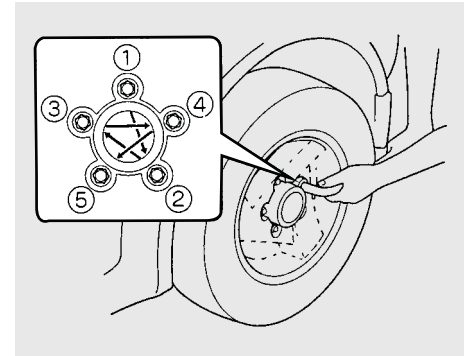

81A057

**Tightening torque for wheel nut**  
**85 Nm (8.7 kg-m, 62.7 lb-ft)**

- 7) Lower the jack and fully tighten the nuts in a crisscross fashion with a wrench as shown in the illustration.

**⚠ WARNING**

Use genuine wheel nuts and tighten them to the specified torque as soon as possible after changing wheels. Incorrect wheel nuts or improperly tightened wheel nuts may come loose or fall off, which can result in an accident. If you do not have a torque wrench, have the wheel nut torque checked by an authorised Maruti Suzuki workshop.

### Jump starting instructions

#### **⚠ WARNING**

- Never attempt to jump start your vehicle if the battery appears to be frozen. Batteries in this condition may explode or rupture if jump starting is attempted.
- When making jump lead connections, be certain that your hands and the jump leads remain clear from pulleys, belts, or fans.
- Batteries produce flammable hydrogen gas. Keep flames and sparks away from the battery or an explosion may occur. Never smoke when working in the vicinity of the battery.
- If the booster battery you use for jump starting is installed in another vehicle, make sure the two vehicles are not touching each other.
- If your battery discharges repeatedly, for no apparent reason, have your vehicle inspected by an authorised Maruti Suzuki workshop.
- To avoid harm to yourself or damage to your vehicle or battery, follow the jump starting instructions below precisely and in order.
- If you are in doubt, call for qualified road service.

#### **NOTICE**

Your vehicle should not be started by pushing or towing. This starting method could result in permanent damage to the catalytic converter. Use jump leads to start a vehicle with a weak or flat battery.

#### **When Jump Starting Your Vehicle, Use the Following Procedure:**

- 1) Use only a 12-volt battery to jump start your vehicle. Position the good 12-volt battery close to your vehicle so that the jump leads will reach both batteries. When using a battery installed on another vehicle, **DO NOT LET THE VEHICLES TOUCH**. Set the parking brakes fully on both vehicles.
- 2) Turn off all vehicle accessories, except those necessary for safety reasons (for example, headlights or hazard lights).

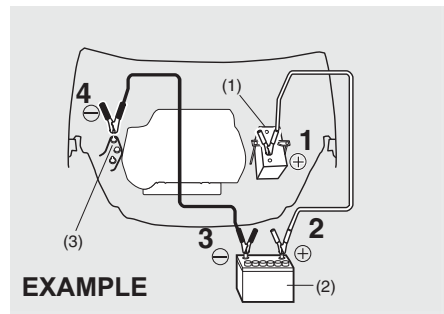

- 3) Make jump lead connections as follows:
  1. Connect one end of the first jump lead to the positive (+) terminal of the flat battery (1).
  2. Connect the other end to the positive (+) terminal of the booster battery (2).
  3. Connect one end of the second jump lead to the negative (-) terminal of the booster battery (2).
  4. Make the final connection to an unpainted, heavy metal part (i.e. engine mount bracket (3)) of the engine of the vehicle with the flat battery (1).

#### **⚠ WARNING**

Never connect the jump lead directly to the negative (-) terminal of the discharged battery, or an explosion may occur.

**▲ CAUTION**

**Connect the jump lead to the engine mount bracket securely. If the jump lead disconnects from the engine mount bracket because of vibration at the start of the engine, the jump lead could be caught in the drive belts.**

- 4) If the booster battery you are using is fitted to another vehicle, start the engine of the vehicle with the booster battery. Run the engine at moderate speed.
- 5) Start the engine of the vehicle with the flat battery.
- 6) Remove the jump leads in the exact reverse order in which you connected them.

**Towing**

If you need to have your vehicle towed, contact a professional service. Your dealer can provide you with detailed towing instructions.

**NOTICE**

**Observe the following instructions when towing your vehicle.**

- **To help avoid damage to your vehicle during towing, proper equipment and towing procedures must be used.**
- **Using the frame hook, tow your vehicle on paved roads for short distances at low speed.**

**2-Wheel Drive (2WD) Manual Transaxle**

Manual transaxle vehicles may be towed using either of the following methods.

- 1) From the front, with the front wheels lifted and the rear wheels on the ground. Before towing, make sure that the parking brake is released.
- 2) From the rear, with the rear wheels lifted and the front wheels on the ground, provided the steering and drivetrain are in operational condition. Before towing, make sure that transaxle is in neutral, the steering wheel is unlocked (vehicle without keyless push start system - the ignition key should be in the "ACC" position) (vehicle with keyless push start system - the ignition mode is ACC), and the steering wheel is secured with a clamping device designed for towing service.

**NOTICE**

**The steering column is not strong enough to withstand shocks transmitted from the front wheels during towing. Always unlock the steering wheel before towing.**

## EMERGENCY SERVICE

---

### If the Starter Does Not Operate

- 1) Try turning the ignition switch to the "START" position or try pressing the engine switch to change the ignition mode to START with the headlights turned on to determine the battery condition. If the headlights go excessively dim or go off, it usually means that either the battery is flat or the battery terminal contact is poor. Recharge the battery or correct battery terminal contact as necessary.

### If the Engine is Flooded

If the engine is flooded with the fuel, it may be hard to start. If this happens, press the accelerator pedal all the way to the floor and hold it there while cranking the engine.

- For petrol engine model, do not operate the starter motor for more than 12 seconds.
- For diesel engine model, do not operate the starter motor for more than 30 seconds.

### If the Engine Overheats

The engine could overheat temporarily under severe driving conditions. If the high engine coolant temperature warning light comes on as overheating during driving:

- 1) Turn off the air conditioner, if equipped.
- 2) Take the vehicle to a safe place and park.
- 3) Let the engine run at the normal idle speed for a few minutes until the high engine coolant temperature warning light goes off.



#### WARNING

**If you see or hear escaping steam, stop the vehicle in a safe place and immediately turn off the engine to let it cool. Do not open the hood when steam is present. When the steam can no longer be seen or heard, open the hood to see if the coolant is still boiling. If it is, you must wait until it stops boiling before you proceed.**

If the high engine coolant temperature warning light does not go off:

- 1) Turn off the engine and check that the water pump belt and pulleys are not damaged or slipping. If any abnormality is found, correct it.
- 2) Check the coolant level in the reservoir. If it is found to be lower than the "LOW" line, look for leaks at the radiator, water pump, and radiator and heater hoses. If you locate any leaks that may have caused the overheating, do not run the engine until these problems have been corrected.
- 3) If you do not find a leak, carefully add coolant to the reservoir and then the radiator, if necessary. (Refer to "Engine Coolant" in the "INSPECTION AND MAINTENANCE" section.)

**NOTE:**

*If your engine overheats and you are unsure what to do, contact your authorised Maruti Suzuki workshop.*

**EXAMPLE**

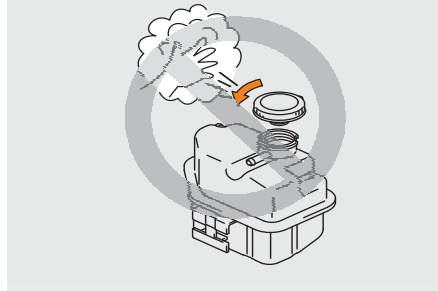

65D350d

**⚠ WARNING**

- It is hazardous to remove the radiator cap (or degassing tank cap for a diesel engine) when the water temperature is high, because scalding fluid and steam may be blown out under pressure. The cap should only be taken off when the coolant temperature has lowered.
- To help prevent personal injury, keep hands, tools and clothing away from the engine cooling fan and air-conditioner fan (if equipped). These electric fans can automatically turn on without warning.

**Warning Triangle**

**EXAMPLE**

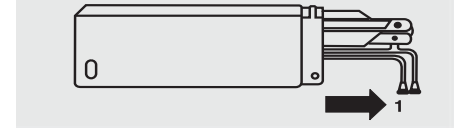

MHO-07-001

In case of vehicle break-down or during emergency stopping, where your vehicle could become a potential traffic hazard, keep the warning triangle, provided with your vehicle, on the road free from any obstacles behind your vehicle so as to warn the approaching traffic, at an approximate distance of 50-100 m. The reflecting side of the triangle should face the oncoming traffic. Please activate the hazard warning lamps before alighting the vehicle to keep the warning triangle.

## EMERGENCY SERVICE

---

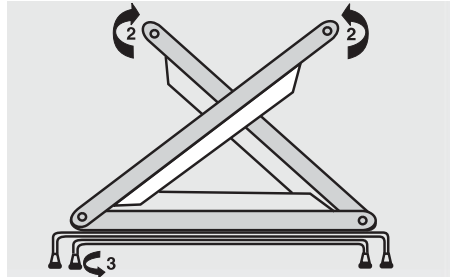

MHO-07-014

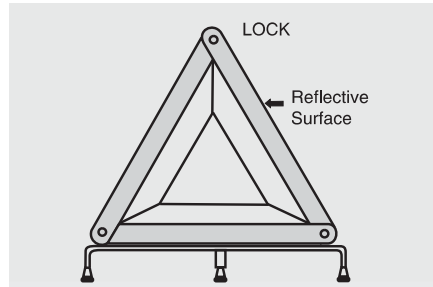

MHO-07-014

- Remove the warning triangle carefully from the cover as shown by arrow 1.
- Open both the reflector arms as shown by arrow 2 and lock the arms with each other with the clip provided in the right arm. Open the bottom stand in counter clock-wise direction as shown by arrow 3. Position the warning triangle behind the vehicle on a plain surface.
- Reverse the removal procedure for keeping inside the cover.



**APPEARANCE CARE**

Corrosion Prevention ..... 9-1  
Vehicle Cleaning ..... 9-2

# APPEARANCE CARE

## Corrosion Prevention

It is important to take good care of your vehicle to protect it from corrosion. Listed below are instructions for how to maintain your vehicle to prevent corrosion. Please read and follow these instructions carefully.

### Important Information About Corrosion

#### Common causes of corrosion

- 1) Accumulation of road salt, dirt, moisture, or chemicals in hard-to-reach areas of the vehicle underbody or frame.
- 2) Chipping, scratches and any damage to treated or painted metal surfaces resulting from minor accidents or abrasion by stones and gravel.

#### Environmental conditions which accelerate corrosion

- 1) Road salt, dust control chemicals, sea air or industrial pollution will all accelerate the corrosion of metal.
- 2) High humidity will increase the rate of corrosion particularly when the temperature range is just above the freezing point.
- 3) Moisture in certain areas of a vehicle for an extended period of time may promote corrosion even though other body sections may be completely dry.
- 4) High temperatures will cause an accelerated rate of corrosion to parts of the

vehicle which are not well ventilated to permit quick drying.

This information illustrates the necessity of keeping your vehicle (particularly the underbody) as clean and dry as possible. It is equally important to repair any damage to the paint or protective coatings as soon as possible.

### How to Help Prevent Corrosion

#### Wash your vehicle frequently

The best way to preserve the finish on your vehicle and to help avoid corrosion is to keep it clean with frequent washing.

Wash your vehicle at least once during the winter and once immediately after the winter. Keep your vehicle, particularly the underside, as clean and dry as possible.

If you frequently drive on salted roads, your vehicle should be washed at least once a month during the winter. If you live near the ocean, your vehicle should be washed at least once a month throughout the year.

For washing instructions, refer to the "Vehicle Cleaning" section.

#### Remove foreign material deposits

Foreign material such as salts, chemicals, road oil or tar, tree sap, bird droppings and industrial fall-out may damage the finish of your vehicle if it is left on painted surfaces. Remove these types of deposits as quickly as possible. If these deposits are difficult to wash off, an additional cleaner may be

required. Be sure that any cleaner you use is not harmful to painted surfaces and is specifically intended for your purposes. Follow the manufacturer's directions when using these special cleaners.

#### Repair finish damage

Carefully examine your vehicle for damage to the painted surfaces. Should you find any chips or scratches in the paint, touch them up immediately to prevent corrosion from starting. If the chips or scratches have gone through to the bare metal, have a qualified body shop make the repair.

#### Keep passenger and luggage compartments clean

Moisture, dirt or mud can accumulate under the floor mats and may cause corrosion. Occasionally, check under these mats to ensure that this area is clean and dry. More frequent checks are necessary if the vehicle is used off road or in wet weather.

Certain cargos such as chemicals, fertilizers, cleaners, salts, etc. are extremely corrosive by nature. These products should be transported in sealed containers. If a spill or leak does occur, clean and dry the area immediately.

#### Store your vehicle in a dry, well-ventilated area

Do not park your vehicle in a damp, poorly ventilated area. If you often wash your vehicle in the garage or if you frequently drive it in when wet, your garage may be damp. The high humidity in the garage may cause or accelerate corrosion. A wet

vehicle may corrode even in a heated garage if the ventilation is poor.

**⚠ WARNING**

Do not apply additional undercoating or rust preventive coating on or around exhaust system components such as the catalytic converter, exhaust pipes, etc. A fire could be started if the undercoating substance becomes overheated.

**Vehicle Cleaning**



76G044S

**⚠ WARNING**

When cleaning the interior or exterior of the vehicle, NEVER USE flammable solvents such as lacquer thinners, petrol, benzene or cleaning materials such as bleaches or strong household detergents. The materials could cause personal injury or damage to the vehicle.

**Cleaning the Interior**

**Vinyl upholstery**

Prepare a solution of soap or mild detergent mixed with warm water. Apply the solution to the vinyl with a sponge or soft cloth and let it soak for a few minutes to loosen dirt.

Rub the surface with a clean, damp cloth to remove dirt and the soap solution. If some dirt still remains on the surface, repeat this procedure.

**Fabric upholstery**

Remove loose dirt with a vacuum cleaner. Using a mild soap solution, rub stained areas with a clean damp cloth. To remove soap, rub the areas again with a cloth dampened with water. Repeat this until the stain is removed, or use a commercial fabric cleaner for tougher stains. If you use a fabric cleaner, carefully follow the manufacturer's instructions and precautions.

**Leather upholstery**

Remove loose dirt with a vacuum cleaner. Using a mild soap or saddle soap solution, wipe dirt off with a clean damp soft cloth. To remove soap, wipe the areas again with a soft cloth dampened with water. Wipe the areas dry with a soft dry cloth. Repeat this until the dirt or stain is removed, or use a commercial leather cleaner for tougher dirt or stains. If you use a leather cleaner, carefully follow the manufacturer's instructions and precautions. Do not use solvent type cleaners or abrasive cleaners.

## APPEARANCE CARE

### NOTE:

- *In order to keep leather upholstery looking good, it should be cleaned at least twice a year.*
- *If leather upholstery becomes wet, immediately wipe it dry with tissue paper or a soft cloth. Water may cause leather to harden and shrink if it is not wiped off.*
- *When parking on sunny days, select a shady place or use a sunshade. If leather upholstery is exposed to direct sunlight for a long time, it may discolor and shrink.*
- *As is common with natural materials, leather is inherently irregular in grain and cowhide has spots in its natural state. These do not affect the performance of the leather in any way.*

### Seat belts

Clean seat belts with a mild soap and water. Do not use bleach or dye on the belts. They may weaken the fabric in the belts.

### Vinyl floor mats

Ordinary dirt can be removed from vinyl with water or mild soap. Use a brush to help loosen dirt. After the dirt is loosened, rinse the mat thoroughly with water and dry it in the shade.

### Carpets

Remove dirt and soil as much as possible with a vacuum cleaner. Using a mild soap solution, rub stained areas with a clean damp cloth. To remove soap, rub the areas

again with a cloth dampened with water. Repeat this until the stain is removed, or use a commercial carpet cleaner for tougher stains. If you use a carpet cleaner, carefully follow the manufacturer's instructions and precautions.

### Instrument panel and console

Remove loose dirt with a vacuum cleaner. Gently wipe dirt off with a tightly squeezed damp clean cloth. Repeat this until the dirt is removed.

### NOTICE

**Do not use chemical products that contain silicon to wipe electrical components such as the air conditioning system, audio, navigation system, or other switches. These will cause damage to the components.**

## Cleaning the Exterior

### NOTICE

**It is important that your vehicle be kept clean and free from dirt. Failure to keep your vehicle clean may result in fading of the paint or corrosion to various parts of the vehicle body.**

### Caring for Aluminum Wheels

#### NOTE:

- *Do not use an acidic or alkaline detergent to wash aluminum wheels. These types of detergent will cause permanent spots, discoloration and cracks on finished surfaces.*
- *Do not use a bristle brush and soap containing an abrasive material. These will damage finished surfaces.*

Washing

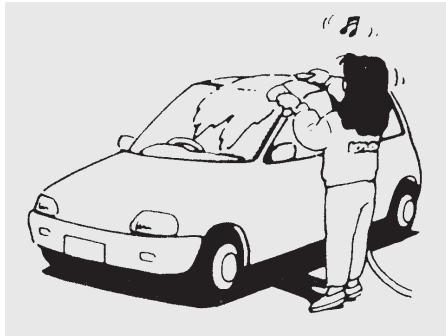

60B212S

**⚠ WARNING**

- Never attempt to wash and wax your vehicle with the engine running.
- When cleaning the underside of the body and fender, where there may be sharp-edged parts, you should wear gloves and a long-sleeved shirt to protect your hands and arms from being cut.
- After washing your vehicle, carefully test the brakes before driving to make sure they have maintained their normal effectiveness.

**⚠ CAUTION**

If your vehicle is equipped with an rain-sensing wiper system, place the wiper control lever in the “OFF” position. If the lever is left in the “AUTO” position, the wipers could unexpectedly operate and cause an injury, and could also be damaged.

When washing the vehicle, park it where direct sunlight does not fall on it and follow the instructions below:

- 1) Flush the underside of body and wheel housings with pressurized water to remove mud and debris. Use plenty of water.

**NOTICE**

When washing the vehicle:

- Avoid directing steam or hot water of more than 80°C (176°F) on plastic parts.
  - To avoid damaging engine components, do not use pressurized water in the engine compartment.
- 2) Rinse the body to loosen the dirt. Remove dirt and mud from the body exterior with running water. You may use a soft sponge or brush. Do not use hard materials which can scratch the paint or plastic. Remember that the headlight covers or lenses are made of plastic in many cases.

**NOTICE**

To avoid damage to the paint or plastic surface, do not wipe the dirt off without ample water. Be sure to follow above procedure.

- 3) Wash the entire exterior with a mild detergent or car wash soap using a sponge or soft cloth. The sponge or cloth should be frequently soaked in the soap solution.

**NOTICE**

When using a commercial car wash product, observe the cautions specified by the manufacturer. Never use strong household detergents or soaps.

- 4) Once the dirt has been completely removed, rinse off the detergent with running water.
- 5) After rinsing, wipe off the vehicle body with a wet chamois or cloth and allow it to dry in the shade.

## APPEARANCE CARE

---

- 6) Check carefully for damage to painted surfaces. If there is any damage, touch-up the damage following the procedure below:
1. Clean all damaged spots and allow them to dry.
  2. Stir the paint and touch-up the damaged spots lightly using a small brush.
  3. Allow the paint to dry completely.

### NOTICE

**If you use an automatic car wash, make sure that your vehicle's body parts, such as spoilers, cannot be damaged. If you are in doubt, consult the car wash operator for advice.**

### Waxing

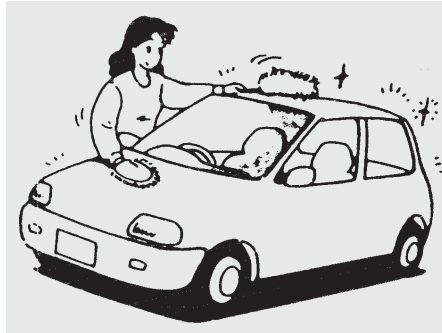

60B211S

After washing the vehicle, waxing and polishing are recommended to further protect and beautify the paint.

- Only use waxes and polishes of good quality.
- When using waxes and polishes, observe the precautions specified by the manufacturers.

# GENERAL INFORMATION

Vehicle Identification ..... 10-1  
Radio Frequency Identification (RFID)  
Tag (If equipped) ..... 10-2

## GENERAL INFORMATION

### Vehicle Identification

#### Chassis Serial Number

##### EXAMPLE

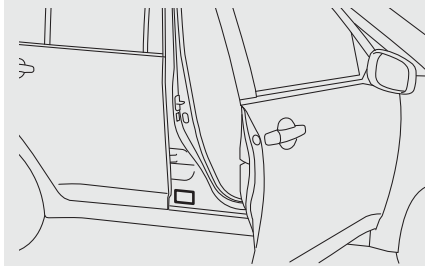

79MH0A01

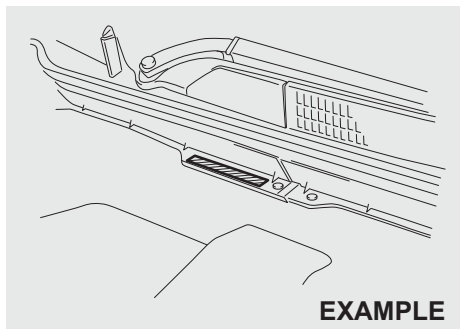

##### EXAMPLE

64MS179

The chassis and/or engine serial numbers are used to register the vehicle. They are

also used to assist your dealer when ordering or referring to special service information. Whenever you have occasion to consult your authorised Maruti Suzuki workshop, remember to identify your vehicle with this number. Should you find the number difficult to read, you will also find it on the identification plate.

#### Engine Serial Number

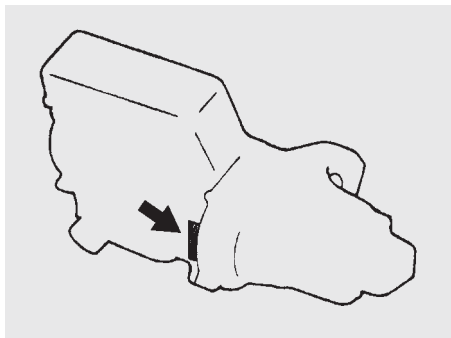

60G128

The engine serial number is stamped on the cylinder block as shown in the illustration.



## Radio frequency identification (RFID) tag (if equipped)

As per Ministry of Road Transport and Highways, the Radio frequency identification (RFID) tag (1) is mandatory for each vehicle for the purpose of electronic toll collection or any other purpose as may be defined by the Government of India.

In case of any damage to RFID tag or replacement of front windscreen, please contact your nearest authorised Maruti Suzuki workshop.

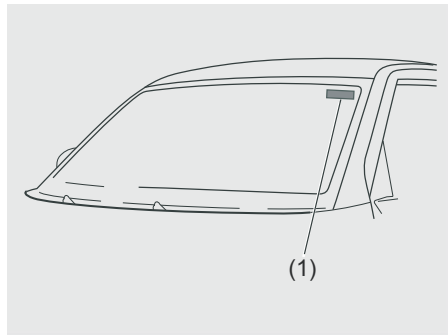

76MH1001

### As seen from inside of the vehicle

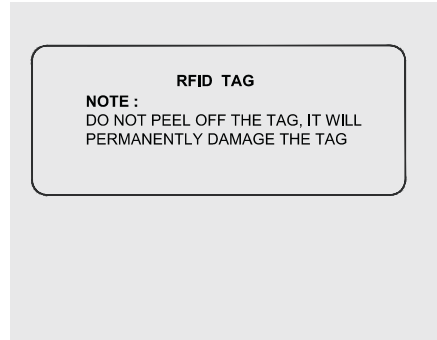

76MH1002

**NOTE:**

*The picture shown is for indicative purpose only. Internal structure of actual device mounted on vehicle may be different.*

### As seen from outside of the vehicle

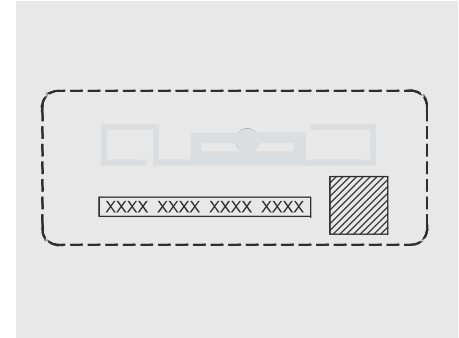

76MH1003

**NOTE:**

*The picture shown is for indicative purpose only. Internal structure of actual device mounted on vehicle may be different.*

**NOTE:**

- RFID tag needs to be registered by government authorized agency (if applicable).
- Any attempt to remove the tag from the windscreen will result in permanent damage to the tag.
- Use of chemical cleaners to clean the windscreen area where the tag is mounted can damage the tag.
- Use of any sharp objects on the tag can damage the tag.

**GENERAL INFORMATION**

---

**MEMO**

-----  
-----  
-----  
-----  
-----  
-----  
-----  
-----  
-----  
-----  
-----  
-----  
-----

# SPECIFICATIONS

**NOTE:**

*Specifications are subject to change without notice.*

M/T: Manual transaxle

<b>ITEM: Dimensions</b>		<b>UNIT: mm</b>
Overall length		4300
Overall width		1765
Overall height	without Roof rails	1585
	with Roof rails	1590
Wheelbase		2600
Track	Front	1535
	Rear	1505

<b>ITEM: Mass (weight)</b>		<b>UNIT: kg</b>	
Curb mass (weight)	D13A	1180 – 1205	
	D16AA	1250 – 1275	
Gross vehicle mass (weight) rating	D13A	1670	
	D16AA	1740	
Permissible maximum Axle Weight	Front	D13A	860
		D16AA	940
	Rear	840	

## SPECIFICATIONS

---

<b>ITEM: Engine</b>		
Type	D13A (DOHC)	D16AA (DOHC)
Number of cylinders	4	4
Bore	69.6 mm	79.5 mm
Stroke	82.0 mm	80.5 mm
Piston displacement	1248 cm <sup>3</sup>	1598 cm <sup>3</sup>
Compression ratio	17.6 : 1	16.5 : 1

<b>ITEM: Electrical</b>		
Battery	D13A	DIN55L
	D16AA	DIN65L
Fuses	See "INSPECTION AND MAINTENANCE" section.	

## SPECIFICATIONS

ITEM: Lights		WATTAGE	BULB No.
Headlight	Halogen	12V 60/55W	H4
	Discharge	12V 25W	D5S
Front fog light		12V 35W	H8
Position light		12V 5W	W5W
		LED	–
Turn signal light	Front	12V 21W	PY21W
	Rear	12V 21W	PY21W
Side turn signal light		12V 5W	WY5W
		LED	–
Tail/brake light		12V 21/5W	P21/5W
High mount stop light		12V 5W	W5W
Reversing light		12V 16W	W16W
License plate light		12V 5W	W5W
Interior light	Glove box light (if equipped)	12V 1.4W	–
	Footwell light (if equipped) / Instrument panel pocket light (if equipped)	LED	–
	Center	12V 10W	–
	Other lights	12V 5W	W5W

## SPECIFICATIONS

<b>ITEM: Wheels and Tires</b>	
Tire size, front and rear	205/60R16 92H <sup>*1*2</sup>
Tire size, spare	205/60R16 92H <sup>*2</sup> (Steel wheel)
Rim size	205/60R16 tire: 16X6J
Tire pressures	For the specified tire pressure, see the Tire Information Label located on the driver's door lock pillar.

\*1 When tire replacement is necessary and if the specified load index and speed rated tire is not available, then use a tire of higher load index and speed rating.

\*2: The spare wheel provided with alloy wheel variant is steel wheel rim, hence follow 4 tire rotation only. (Refer: Section "Inspection and maintenance")

<b>ITEM: Recommended Fuel/Lubricants and Capacities (approx.)</b>		
Fuel		48 L
Engine oil	D13A	3.2 L (replacement with oil filter)
	D16AA	5.25 L (replacement with oil filter)
Engine coolant	D13A	6.0 L (including reservoir tank)
	D16AA	5.5 L (including reservoir tank)
Manual transaxle oil	5M/T	2.6 L
	6M/T	2.1 L
Brake fluid / Clutch fluid		Refill to the proper oil level according to the instructions in the "INSPECTION AND MAINTENANCE" section.

Prepared by  
**MARUTI SUZUKI INDIA LIMITED**

Service Division  
July, 2015

Part No. 99011M64M00-74E  
Printed in India

**For 24 X 7 assistance, contact Toll Free number 1800 200 6392<sup>#</sup>**  
**(NEXA)**

*# No STD code to be prefixed.*

Service Division

**MARUTI SUZUKI INDIA LIMITED**

Palam Gurgaon Road, Gurgaon - 122 015 (Haryana)

[www.marutisuzuki.com](http://www.marutisuzuki.com)