



COMET **EV**

OWNER'S MANUAL



MORRIS GARAGES
Since 1924

- ◆ Use Blower or infotainment system only in READY mode.
- ◆ Ensure door, hood and tailgate are properly locked.
- ◆ Please Do not use Accelerator & Brake pedal simultaneously
- ◆ **Prohibited to drive the vehicle in flood / high water level conditions.**

Welcome to the world of MG!!!

Thank you for choosing MG COMET EV

This manual will familiarize you with the operation and maintenance of your new vehicle. It will also provide you important safety information. Please do read it carefully and follow the recommendations. This manual is like a permanent part of your car. It would go a long way in ensuring a safe and trouble-free operation and running of your MG COMET EV.

In case of any query, please feel free to call our 24 hours Helpline at 1800 100 6464 or email us at: pulsehub@mgmotor.co.in

Find your nearest MG authorized dealer by visiting www.mgmotor.co.in/tools/dealers

SAFE and HAPPY DRIVING

From
Team MG India

Welcome to the world of MG!!!

Thank you for choosing MG COMET EV

This manual will familiarize you with the operation and maintenance of your new vehicle. It will also provide you important safety information. Please do read it carefully and follow the recommendations. This manual is like a permanent part of your car. It would go a long way in ensuring a safe and trouble-free operation and running of your MG COMET EV.

In case of any query, please feel free to call our 24 hours Helpline at 1800 100 6464 or email us at: pulsehub@mgmotor.co.in

Find your nearest MG authorized dealer by visiting www.mgmotor.co.in/tools/dealers

SAFE and HAPPY DRIVING

From
Team MG India

Contents

Preface	1		
Introduction	1		
The Owner's Handbook	1		
Status at Time of Printing	1		
Symbols Used	1		
Precautions in the Event of an Accident..	3		
Prompt Information	4		
Product Information	7		
Vehicle Identification Information.....	8		
Keys, Doors and Windows	9		
Seats and Protective Devices	14		
Instruments and Controls	25		
Lighting	34		
Temperature Control System	36		
Driving and Controls	37		
START/STOP Button*.....	37		
"READY" State (Start State).....	38		
HHC*.....	40		
Gearshift Knob.....	41		
Anti-Lock Brake System (ABS).....	42		
		Electric Brake Force Distribution (EBD) System	42
		Electronic Stability Control (ESC) System*.....	42
		Parking Brake.....	44
		Electronic Parking Brake (EPB)*	44
		Automatic Vehicle Hold (AVH)*	45
		Electric Power Steering (EPS) System	46
		Energy Recovery System	47
		Charging Specification	48
		Emergency power off*	54
		TPMS	54
		Internet of vehicles*.....	54
		Vehicle Maintenance	55
		Exterior.....	56
		Interior.....	56
		12V Battery.....	57
		Best Battery Service.....	57
		Car Parking Period.....	58
		Battery Charge with Ground Equipment	59
		Battery Removal	60
		Battery Replacement	60
		Battery Installation	60
		Brake Fluid	61
		Windshield Washing Fluid.....	61
		Fuse.....	61
		Maintenance	63
		Tire Pressure.....	64
		Tire & Wheel Maintenance.....	64
		Tire Rotation	65
		Jump Start (Dead battery)	66
		Towing.....	66
		Cleaning & Vehicle Care.....	68
		Vehicle Interior Maintenance and Cleaning.....	69
		Vehicle Exterior Maintenance and Cleaning	71
		Technical Data	75
		Main Parameters and Performance Indices of Drive Motor.....	76

Contents

Main Performance Parameters of Traction Battery Sytem (6.6Kw).....	77
Main Vehicle Mass Parameters	78
Main Liquid Parameters.....	78
Main Vehicle Dimension Paramters	79
Wheel Alignment (Unladen) Parameters	79
Tire Inflation Pressure (Cold State).....	79
List of Accompanying Parts.....	80
Delivery of Your Vehicle	81
MG Motor New Vehicle Warranty	85
MG Roadside Assistance 24x7	92
Service Coupon	97
Change of Ownership Record	105
Preventive Maintenance Schedule for Normal Operation	106
MG Motor India Sales and Service Network	110

Introduction

The Owner's Handbook

This handbook describes all of the vehicles and standard equipment specification within the model range. Some of the information therefore, may not apply to your particular car.

Always remember that if you have any queries concerning the operation or specification of your car, your MG Authorised Repairer will be glad to advise you.

The illustrations in the Owner's Handbook are for reference only.

The information presented in this manual may vary slightly depending on vehicle configuration, software version and sales area.

Status at Time of Printing

MG operates a policy of constant product improvement and therefore reserves the right to change specifications without notice at any time. Whilst every effort is made to ensure complete accuracy of the information in this publication, no liabilities for inaccuracies or the consequences thereof, including loss or damage to property, or injury to persons, can be accepted by the manufacturer or MG Authorised Repairer who supplied the publication, except in respect of personal injury caused by the negligence of the manufacturer or MG Authorised Repairer .

Symbols Used

The following symbols used within the handbook call your attention to specific types of information.

Warning



This warning symbol identifies procedures that must be followed precisely, or information that must be considered with great care, in order to reduce the risk of personal injury or serious damage to the car.

Important

IMPORTANT

The statements stated here must be followed strictly, otherwise your car could be damaged.

Note

Note: This describes helpful information.





This symbol indicates that parts described must be disposed of by authorised persons or bodies to protect the environment.

Asterisk

An asterisk (*) appearing within the text, identifies features or items of equipment that are either optional, or are only fitted to some vehicles in the model range.

Illustration Information

 Identifies components being explained.

 Identifies movement of components being explained.

Precautions in the Event of an Accident

- **⚠** • **Ensure the vehicle is in P, the parking brake is applied and the vehicle power system is OFF.**
- **If any cables on the vehicle are exposed, in order to prevent electric shock or even death DO NOT make any contact with any cable.**
- **If the vehicle catches fire, and the fire is small and slow, a carbon dioxide extinguisher can be used to extinguish the fire, and contact the fire services as soon as possible; if the fire is large and spreading quickly, immediately evacuate the vehicle and contact the fire services immediately.**
- **If the vehicle is involved in a collision and cannot be re-started, the negative cable of 12V battery MUST be disconnected prior to rescue.**
- **When the vehicle is completely or partially immersed in water, switch off the vehicle power system and evacuate the car immediately. The negative cable of 12V battery MUST be disconnected prior to rescue or as soon as the vehicle is refloated/removed from the water. Observe the water/vehicle for any abnormal signs such as excessive bubbles or noises, this may indicate battery short circuit issues. If no signs are evident, there should not be a shock risk from the bodywork and recovery can commence.**
- **If your car is being recovered by an independent recovery agent, please contact an MG Authorised Repairer for guidance.**

Prompt Information

Notes

The content marked with “Note” indicates matters need to be noted during vehicle operation. Ignoring such information may lead to wrong operation.

Warning

The content marked with “Warning” indicates risks of accidents or injuries. Ignoring such information may lead to injuries.

Precaution

The content marked with “Caution” indicates possibility of vehicle damage. Ignoring such information may lead to vehicle damage.

Danger

The content marked with “Danger” indicates risks of fatal injuries. Ignoring such information may endanger lives.

The asterisk “*” behind a title or text indicates that the equipment mentioned is optional, and your car may not have such equipment. Please refer to the actual vehicle configuration.

The Company reserves the copyright of this Manual.

Overview

1. This vehicle is a battery electric vehicle, and some of its operations and characteristics are different from those of traditional fuel vehicles. Therefore, please read this Manual carefully before using this vehicle.
2. This vehicle is driven by electric energy. It is equipped with two batteries. One is the traction battery, which is located under the vehicle chassis to provide driving power for the vehicle. The other is an ordinary 12V automotive battery, located in the front compartment, which provides power for instruments, lamps, and corresponding control modules.
3. The traction battery must be charged with 230V alternating current (i.e. general household power supply). When charging the traction battery with household alternating current, ensure that all wires, ports and plugs on the charging line are rated at a load of not less than 16A (>3.6KW).

Be sure to have a professional electrician to install the charging circuit for you. The charging circuit must be grounded cor-

rectly and the main switch and leakage protection device must be installed.

4. The orange cable in this vehicle is a high voltage cable. Do not touch it. Please pay special attention to the warning signs posted on the shells of high-voltage components.
5. Do not leave electric components switched on when not in READY mode, this may cause the battery to become flat, resulting in the failure of the ability to set vehicle into READY mode and the reduction of battery life.
6. The vehicle will mainly consume the power from the traction battery after it enters the "READY" state (the "READY" indicator on), and the lamps and the air conditioner can be normally used for a long time. The traction battery begins to charge the 12V battery.

Precaution

After vehicle delivery, please fully charge the traction battery to 100% in time before the power is lower than 30% to maintain the traction battery.

Notes

1. ***There is high voltage (HV) and low voltage (LV) electrical equipment in the vehicle. The LV electrical equipment, including instruments, audio system, lamps, horns, blowers, etc., has a rated operating voltage of 12V.***

The high-voltage electrical equipment includes a drive motor, a motor controller, a traction battery pack, a charging distribution unit (CDU), an A/C compressor, an A/C heater, etc.

2. ***Please pay attention to the relevant warning labels on the high-voltage components. To avoid electric shock, do not touch high-voltage components, high-voltage cables, and their connectors.***

3. **Do not touch any exposed or damaged orange HV cable. Otherwise, you may be exposed to a risk of electric shock.**
4. **Do not disassemble or modify the electrical equipment in the vehicle. Otherwise, you may cause serious consequences such as short circuit, burning and fire.**
5. **In case of vehicle accident: If time permits, turn off the power supply of the vehicle, pull up the handbrake, turn on the hazard warning lamp, place a triangle warning sign, get off the vehicle and contact the service center immediately. If time does not permit, such as when the vehicle is on fire or gives out strong burnt smell, please turn off the vehicle power immediately and pull up the hand brake to escape from the vehicle.**
6. **If the fire is serious or develops rapidly, immediately stay away from the vehicle and call the fire alarm. Otherwise, use a water-based fire extinguisher to put out the fire and keep a safe distance from the fire source.**
7. **If you need to replace the traction battery, please hand over the old one to a MG authorized service center. Discarded traction batteries will pollute the environment and even cause injury.**
8. **The traction battery's warranty period is 8 years or 120,000 km (whichever comes first). MG will repair or replace it free of charge.**
9. **When the power bar of the instrument cluster turns red, it indicates that the traction battery is low. Charge it as soon as possible. Otherwise, the service life of the traction battery may be shortened. Charge the battery fully at least once every two weeks for maintenance when the vehicle is in use. If you won't drive your vehicle for a long time, charge or discharge the traction battery to about 60% power. To extend the service life of the traction battery, it is recommended to charge the traction battery once every month.**

Danger

Do not modify the charging port or charging equipment. Otherwise, charging faults or even fire may occur.

Danger

Do not disassemble the lithium ion traction battery pack without authorization, or even disassemble the lithium ion traction battery pack. When dealing with accidents, relevant professionals shall not cut or impact the lithium ion traction battery pack, to prevent it from leaking and deforming, and thus injuring any one.

Product Information

Vehicle Identification Information	8	Brake Fluid	61
Keys, Doors and Windows	9	Fuse	61
Door Lock Remote Control System	9	Lamp Fogging.....	62
Seats and Protective Devices	14	Wheels and Tires	62
Seat Adjustment	14		
Seat Belt	15		
Child Seat	16		
Airbag System	20		
Instruments and Controls.....	25		
Instrument Panel Indicator	28		
Lighting	34		
Temperature Control System	36		
A/C control panel	36		
Driving and Controls	37		
Parking Brake	44		
Vehicle Maintenance	55		
Driver Checklist	55		
Front Compartment	56		
12V Battery	57		
Best Battery Service.....	57		

Vehicle Identification Information

1. Vehicle Identification Number (VIN)
2. Drive Motor Production Number

Always quote the Vehicle Identification Number (VIN) when communicating with MG Authorized Service Center. If the drive motor or electric drive system is involved, it may be required to provide the identification numbers of these assemblies.

Vehicle Identification Location

Vehicle Identification Number (VIN)

- The vehicle identification plate is located on the door frame of co-driver side door.

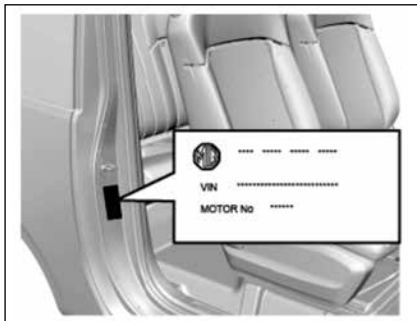

Note: The VIN information can be extracted from the vehicle using the approved diagnostic equipment present at MG Authorized Service Center.

Drive Motor Production Number Mark No.

Stamped on the lower part of the drive motor housing.

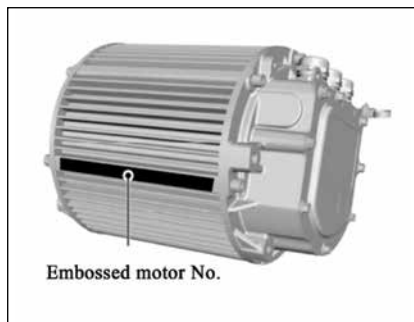

Keys, Doors and Windows

Type 1 - Folding Key *

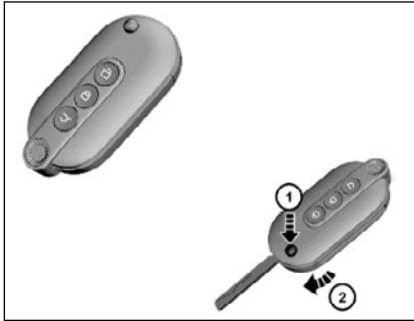

Type-2 - Intelligent Key*

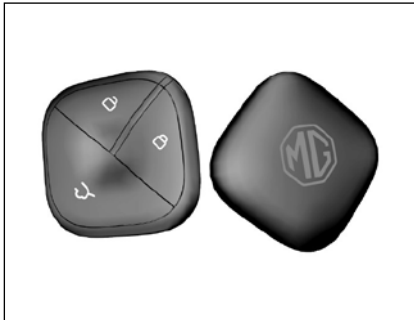

- Please keep the spare key* in a safe place - not in the car!
- It is recommended that spare keys* are not kept on the same key* ring, since this may cause interference and prevent correct key* recognition and therefore prevent the correct operation of the vehicle power system.
- The smart key* contains delicate circuits and must be protected from impact and water damage, high temperature and humidity, direct sunlight and the effects of solvents, waxes and abrasive cleaners.

Different models may be provided with different keys. Please refer to real vehicles. If your key is a folding key, press the release button 1 to automatically eject the mechanical key.

Replacing the Key Battery

Battery Replacement Inside the key remote control, there is a lithium battery whose service life is 2 years generally. When the remote control distance is shortened gradually (i.e. must get closer to the vehicle), it indicates a low battery. The key battery cannot be charged. After the battery runs out, please go to the MG Authorised Service Center to have the battery changed.

Door Lock Remote Control System

The effective distance of remote control is about 10m without shielding. The remote control range may be different in different environments.

 : Remote lock button. After the doors are closed, press the remote control locking button once to lock all doors. The hazard warning lamp flashes twice to enter the anti-theft state.

 : Remote unlock button. Press the remote control unlocking button once to unlock all doors. The hazard warning lamp flashes once, and the anti-theft state is released.

🔓: Tailgate opening button. Press tailgate opening button for about 2s to unlock the tailgate.

Warning Sound

If the door fails to lock after the remote locking button is pressed, the vehicle will horn and/or flash a hazard warning lamp. Specific situations include:

1. A door/some doors not closed (including tailgate);
2. The door lock is under thermal protection;
3. The ignition switch is not at LOCK position;
4. The keyless entry system (if configured) detects a legal key in the vehicle.

Locking and Unlocking from Outside the Vehicle

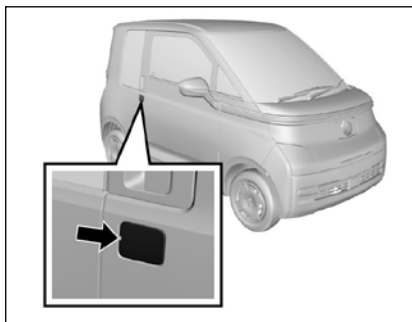

To open doors from inside or outside, unlock the doors first, and pull the external or internal door handles.

Notes

When you leave the vehicle unattended, you must lock all doors and take the key with you. If the doors are unlocked, the vehicle may be stolen.

Locking and Unlocking from Inside the Vehicle

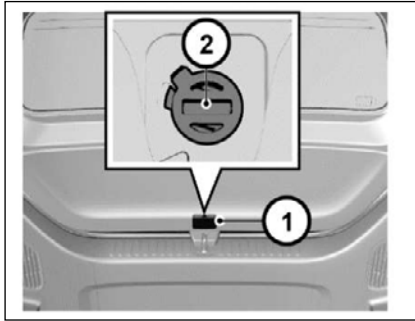

As shown in the figure, there is a door lock button on each door. Press the door lock button forward to lock, and pull it backward to unlock. The door lock button on the driver-side door can also be used as the central door lock.

Tailgate Opening from Inside the Trunk

If the tailgate fails to open in this way, it can still be opened by the following steps:

Open the tailgate lock trim cover to see the slotted knob. Turn the knob clockwise with a straight screwdriver to open the trunk.

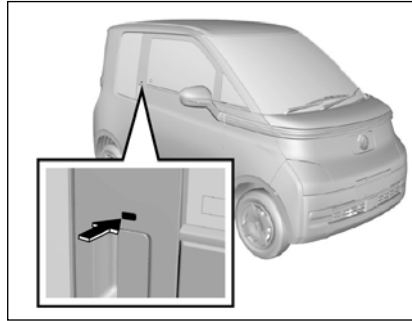
Keyless Entry/Locking*

Press the button on the front door handle to lock or unlock the door. The system operates when:

1. The ignition switch is at LOCK position;
2. The key is within the PEPS sensing range (1.2m);
3. All doors are closed;
4. The key is not in the vehicle.

Tailgate Keyless Unlocking/Locking*

Press the button on the tailgate to lock or unlock the tailgate. The system operates when:

1. The ignition switch is at LOCK position;
2. The key is within the PEPS sensing range (1.2m);
3. All doors are closed;
4. The key is not in the vehicle.

Charging Port Lock Manual Release

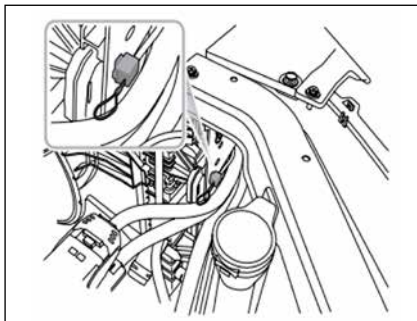

There is a cable given inside the front compartment hood, by pulling it together with charging gun, the Gun can be extracted from the vehicle during any malfunctioning or emergency situations.

Electric adjusted outsiders rear view mirror / Power Fold ORVM

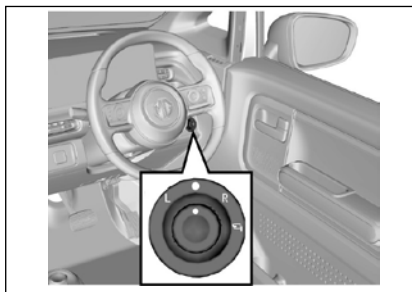

The exterior rearview mirror can be adjusted through the electric adjustment switch on the right side of the instrument panel. The adjustment steps are as follows:

1. Select the rearview mirror to be adjusted. Turn the rocker to the “L” (left) or “R” (right) on the selector switch to display the left or right rearview mirror to be adjusted.
2. Toggle the rocker to adjust the selected rearview mirror.
3. Turn the rocker to the folding character position folds the exterior rearview mirror. To unfold, turn in the opposite direction.

4. If the rocker not at the folding character
When the remote locking, passive key locking, or remote locking is activated and successful, the exterior rearview mirrors will automatically fold.

When the remote unlocking, passive key unlocking, or remote unlocking is activated and successful, the exterior rearview mirrors will automatically unfold.

Notes to Electrical Folding of Frozen Outside Rearview Mirror

If the outside rearview mirror and its spindle are frozen, please remove the freeze first, and use the electric folding/ unfolding functions. For example, if the mirror is frozen after the vehicle is parked outdoors for a night in winter, please remove the freeze first, and use the remote control or the passive entry button to unlock doors. Then, the outside rearview mirror will be unfolded smoothly. If the freeze is not removed, the freeze will hinder the movement of the rearview mirror, damaging the mirror.

Power Window

When the ignition switch is at the ON position, control the power window with the power window switch on the center console.

When the key is turned from the ON position to the ACC or LOCK position, or after the key is removed, all windows can still be controlled by the power window switch within 30 seconds.

Driver-side Power Window Initialization Adjustment

In some cases, the one-key up/down of the driver side window may fail, due to such as reconnection after battery replacement. When this occurs, the window needs to be initialized by programming. First, lift the driver-side switch until the window is completely closed, hold it for 5 seconds and then release it. At this time, the initialization is completed. If not, please contact the Aftersales Service Center for maintenance.

Seats and Protective Devices

Seat Position and Backrest Normal Condition



- When you sit on the seat, make your hip as close to the backrest as possible. Adjust the distance between the seat and the pedal so that your leg slightly bends when you depress the pedal. The passenger's seat shall slide as backward as possible.
- When you sit on the seat, make your shoulders lean on the backrest as backward as possible. Set the backrest inclination angle to make your arm

conveniently to reach the steering wheel while slightly bending the arm. Keep the shoulders leaning against the backrest while turning the steering wheel. The backrest shall not incline excessively backward. We suggest that the inclination angle of all backrests shall not be more than 25°.

- The seat height shall be so set that the occupant can see all directions and the positions of all display instruments. The head must be at least one hand away from the roof lining. The thighs are right on the seat without constriction.

Seat Adjustment

Seat Position Adjustment



Seat Backrest Adjustment



Front Passenger Seat One-button Access*



Unlock the handle according to the direction shown in the figure, and adjust the backrest to the foremost end.

When it is confirmed that the backrest is in the foremost position, the slide rail is triggered to unlock, and the seat can slide freely forward and backward to facilitate the entry and exit of rear passengers

Adjust the backrest backward to an appropriate position, and the seat slide rail will return to the locked state.

Seat Belt



The seat belt is designed only for one passenger to use.

They are not applicable to a passenger under 12 years old or under 150 cm high. Check all parts of the seat belt system for any damage or abnormal function regularly.

Please replace the damaged parts and components. It is strongly recommended to have the seat belt or used seat belt tensioner replaced at the Aftersales Service Center after an accident.

Wearing



1. Pull out the seat belt from the retractor, and fasten it across the body without twisting.

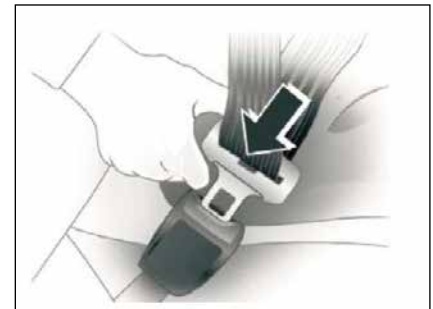

- Put the latch plate in the buckle for fixing. When driving, pull the shoulder belt forcibly to adjust the tightness of hip belt.

Too loose or heavy clothing will hamper close wearing the seat belt. Do not place any object (such as hand bag and mobile phone) between the seat belt and your body.

Unlock



To unbuckle the seat belt, please press the red button on the buckle.

Seat Belt Use During Pregnancy



The seat belt provide protection for everybody, including a pregnant woman. Like all passengers, if pregnant women do not wear the seat belt, severe personal injuries are more likely to be caused to them. Pregnant women shall wear a hip/shoulder seat belt during the whole pregnancy, and the hip belt shall be fastened as low as possible. The best way to protect a fetus is to provide safety protection to its mother. If the seat belt is fastened correctly, the fetus is not vulnerable to injury in case of a collision. Wearing the seat belt correctly is the key to providing the best protection for pregnant women and anyone else.

Child Seat

The vehicle is not equipped with a child seat. If you want to add one, a child seat that is applicable to ISOFIX “general” type can be selected. A child seat can only be placed on the second row because the front seat is not equipped with the anchor system bracket. The statistical data of accidents show that placing the child seat on the second row seat can largely improve the child safety.

Child Restraint System



According to European Regulation ECE R44, child restraint systems can be divided into the following 5 groups:

Group 0: For children weighing less than 10 kg.

Group 0+: For children weighing less than 13 kg.

Group I: for a child weighed between 9 kg to 18 kg;

Group II: for a child weighed between 15 kg to 25 kg;

Group III: for a child weighed between 22 kg to 36 kg.

Please select a suitable child seat according to your child's weight and body size.

For children under 1 year old, a rear-facing child seat must be used as their bones are still fragile.

Approved Child Restraint Position(for non ISOFIX Child Restraints)

Mass Group	Seating position(or other site)						
	Front Passenger	Second OB		Second Centre	Third OB		Third Centre
		LH	RH		LH	RH	
Group 0 Up to 10 kg	X	X	X	NA	NA	NA	NA
Group 0 up to 13 kg	X	X	X	NA	NA	NA	NA
Group I 9 to 18 kg	X	$\frac{UF}{U}$	$\frac{UF}{U}$	NA	NA	NA	NA
Group II 15 to 25 kg	X	$\frac{UF}{U}$	$\frac{UF}{U}$	NA	NA	NA	NA
Group III 22 to 36 kg	X	$\frac{UF}{U}$	$\frac{UF}{U}$	NA	NA	NA	NA

Note:Description of letters in the table:

U =Suitable for universal child restraint systems approved for this mass group.

X =Seat position not suitable for child restraint systems in this mass group.

Child Seat Fixing Device

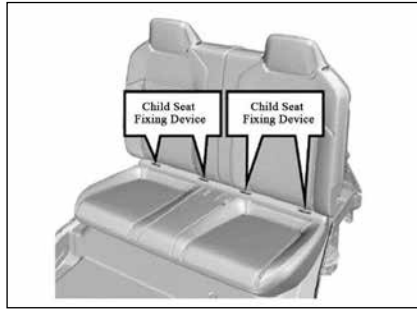

Adjust the child seat:

1. The child seat fixing device is on the joint between the second row set backrest and the seat cushion. Its position can be identified by a label at the lower end of the seat back. The left and right seats are equipped with a child seat fixing device respectively.

2. Clear up the objects on the seat. Remove the seat belt and seat belt buckle to avoid affecting the accurate fixing of the child seat.
3. Put the child seat on the second row seat.



4. Connect the fixing hook on the child seat to the onvehicle fixing device. Operate according to the child seat instructions.

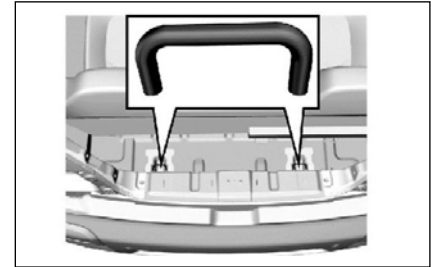

5. Connect the upper strap of the child seat to the rear fixing point of the vehicle. These fixing points are present under the carpet behind the second row.

Refer to the child seat instructions to get to know when and how to strain the upper strap.

6. Push and pull the child seat in all directions to make sure it is safely secured.
7. Make sure that the child seat temperature is not very high before putting a child in the seat.

In case of a serious collision accident, the child seat fixing device may be damaged. Some parts may require repair and replacement. Please check the child seat fixing device after a collision.

Airbag System

The vehicle may have the following airbags:

- Driver frontal airbag.
- Co - driver airbag

For all airbags, the letter “AIRBAG” is marked on the trim panel or the label near the opening where they are deployed. The word “AIRBAG” on the driver’s airbag is located in the middle of the steering wheel, the front passenger’s frontal airbag word is located on the instrument panel..

The airbag can supplement protection on the basis of correct wearing of the seat belt. Although nowadays the airbags are designed to reduce the injury risks caused by the impact force when the airbag is inflated, all airbags must be inflated rapidly to exert its effect.

Airbag Indicator



On the instrument panel, there is an airbag indicator which displays the airbag shape symbol. The system will check whether the airbag circuit system has a fault and give corresponding prompt through the indicator. Refer to the Chapter “Instruments and Controls” for detailed information.

Airbag Position

Driver Frontal Airbag

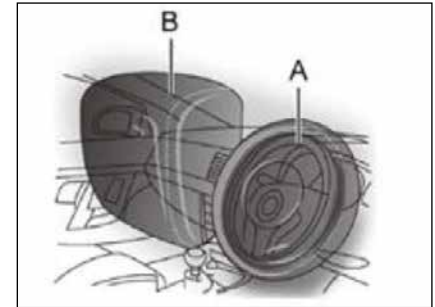

As shown in the Figure A above, the driver frontal airbag is located in the middle of the steering wheel.

As shown in Figure B, the front passenger frontal airbag is located on the front passenger side instrument panel.

When are Airbags Inflated?

The frontal airbag is designed to inflate in a mild-to-severe frontal collision to help reduce the risk of severe head and chest injury to the driver.

Whether the frontal airbag inflates depends not only on the speed of the vehicle, but on the object being collided with, the direction of the collision, and the vehicle deceleration within the unit time during the collision.

The frontal airbag may be inflated in different collision speed. It depends on whether the vehicle hits the object straight or at an angle at the moment of the collision, and on whether the collided object is fixed or moving, nondeformable or deformable, narrow or wide. Due to different design of each model, the collision inflation conditions of the frontal airbag may vary. Frontal airbags do not inflate when the vehicle rolls over or subject to rear impact and side impact. The frontal airbag may not be inflated in slight head-on or nearly head-on collisions, lateral or diagonal collisions, collisions to cylindrical objects (such as telegraph pole and tree trunk), rear-end collisions under large vehicle (trucks, etc.) breast board and lateral glancing collisions.

The front seat airbag will inflate according to the collision position in case of a moderate or severe collision.

The front seat airbag do not inflate in the event of a minor frontal collision, near frontal collision, vehicle rollover, or rear-end collision. They also will not inflate in the event of a minor side, frontal or diagonal collision only.

In case of a collision, the front seat airbag on the struck side will inflate. However, airbags will not inflate in all types of collisions. For a specific accident, it is not easy to determine whether the airbag should inflate according to the causal relationship, vehicle damage or maintenance costs. Your vehicle is equipped with collision sensors and diagnostic modules. If the accident is not a minor one, the diagnostic module will record relevant information after the crash. If your airbag fails during a collision, please contact the Aftersales Service Center for professional analysis and diagnosis.

How is the Airbag Inflated?

In the inflation process, the sensing system will send an electronic signal to trigger the gas generator; the generator will release gas to inflate the airbag and to make the airbag pops up from the cover plate. The gas generator, airbag and relevant members are all components of the air bag module.

How does the Airbag Provide Protection?

The airbag supplements protection provided by the seat belt by distributing the impact force more evenly to the passenger's body. However, when passengers move not toward the airbag during a collision, and when external objects invade the vehicle, the airbag cannot provide corresponding protection. The airbag shall only be deemed as a supplementary device of the seat belt.

What Will You See After the Airbag Inflates?

After the airbag is inflated, it will be deflated quickly. Somebody may not note that the airbag is ever inflated because the bleeding speed is very fast. For deflated airbag, some smoke and dust may come out from its air vent.

Warning

When the airbag is inflated, there may be dust spread in the air. All persons in the vehicle shall get off the vehicle as soon as possible. If you have a breathing problem and cannot get off the vehicle after airbag inflation, open windows or doors to get fresh air. If you have a breathing problem after the airbag is inflated, please see a doctor as soon as possible.

If the vehicle power supply system can still work normally after a crash, the vehicle has features that automatically unlock the doors, turn on hazard warning lights and turn off the power system after the airbag is inflated. The driver can use the corresponding function switch to lock doors, turn off indoor lamps and turn off the hazard warning lamp.

The triggering of the airbag may also cause damage to the windshield.

- The airbag can only be inflated once as per its design. After the airbag is inflated, some parts of the airbag system need to be replaced. If you do not have these parts replaced, the airbag system will be unable to provide protection in next collision accident. The airbag system parts that shall be replaced include the airbag module, airbag control module, seat belt pretensioner and other parts.
- Repair, maintenance, and replacement work related to airbag systems can only be carried out by technicians with appropriate qualifications. Improper repair and maintenance may cause the airbag system cannot function normally. Please drive to the MG Authorized Service center for repair and maintenance.

Warning

If the air bag cover is damaged, opened or broken, the air bag may not function normally. It shall be repaired as soon as possible.

Warning

Never stick or cover any object on the airbag cover surface or refit the airbag cover; never try to repair, adjust or remove or install any airbag system component; never try to refit the front bumper of the vehicle body by yourself.

Other Situations Where the Airbag May Inflate Except for Collisions

If the vehicle bottom is impacted seriously, the airbag may also be inflated. Refer to the following examples.

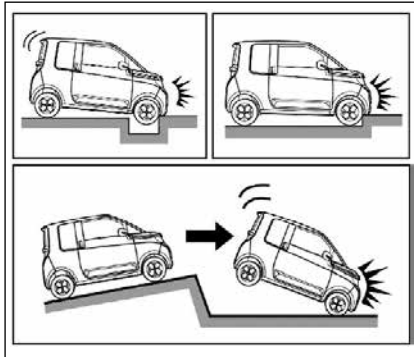

- Hit a road shoulder, sidewalk edge or hard surface.
- Fall into or drive into a deep pit.
- Wheel hard landing or vehicle fall.

Frontal Airbag May Not be Inflated in the Following Collisions

The frontal airbag will usually not be inflated in case of side collisions, rear-end collision by another vehicle, turnover or low-speed head-on collisions. Regardless of the collision type, the driver's frontal airbag will only inflate if the vehicle generates sufficient forward deceleration.

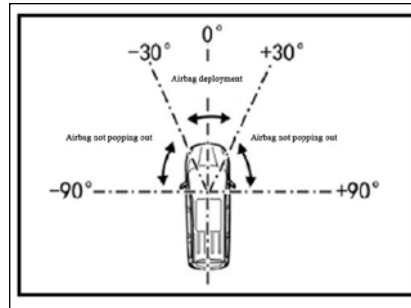

- Head-on collision angle over 30° from vehicle longitudinal direction.

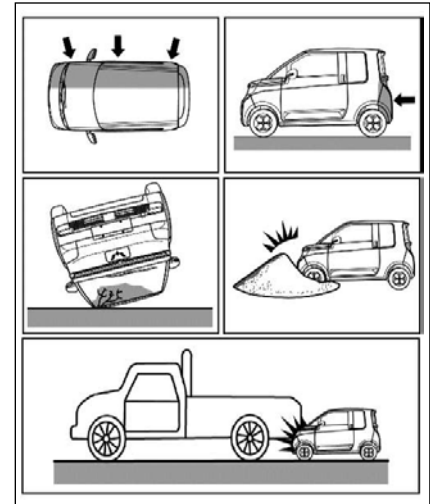

- Side collision
- Rear-end collision
- Overturn, falling from high place, rolling
- Hit deformable objects, such as sandpile, guard bar, column and tree
- Hit into front vehicle bottom, especially truck bottom

Important Suggestion!



Do not install rear-facing child seats on front seats protected by airbags! Otherwise, children may be injured or even killed.

Important Note



Do not use a backward-facing child restraint system on a seat (front seat) protected by a frontal air bag (in activated state). Otherwise, severe injuries or even death may be caused to the child when the air bag is deployed.

Instruments and Controls

1. Left defrosting vent
2. Left side air vent
3. A/C control knob
4. Central air outlet
5. Front defrosting vent
6. Driving mode button (economy/normal/sports)
7. Wiper combination switch
8. Instrument panel combination button
9. Instrument panel display
10. Horn button/airbag
11. Right side air vent
12. Audio and entertainment system
13. Lamplight combination switch
14. Right defrosting vent
15. Electric exterior rearview mirror adjusting button
16. Tire pressure monitoring switch
17. Headlamp adjustment knob
18. OFF button
19. Front hood release handle

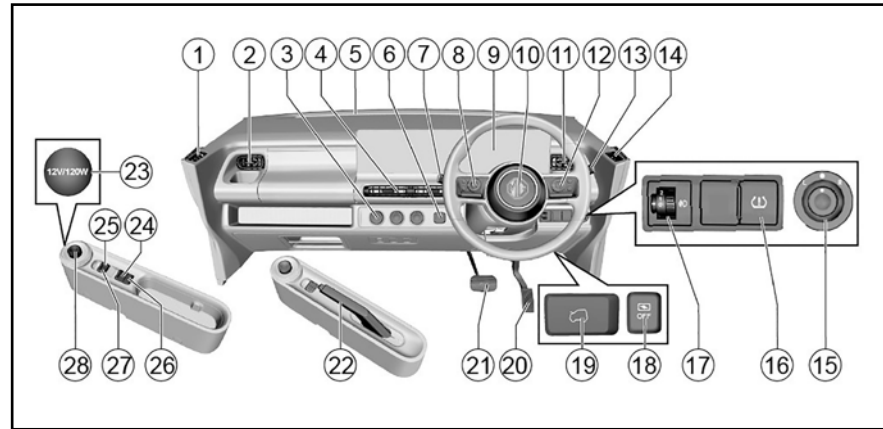

20. Accelerator pedal
21. Brake pedal
22. Manual parking brake*
23. Power socket
24. Electronic parking brake switch*
25. Right window switch
26. AVH switch *
27. Left window switch
28. Gearshift knob

Instrument Panel Display

1. Indicator display
2. Speedometer and gear display
3. Power and range display
4. Odometer display
5. Vehicle parameter display and setting
6. Driving mode display

Note: The specific display shall be subject to the actual vehicle.

Type 1 *

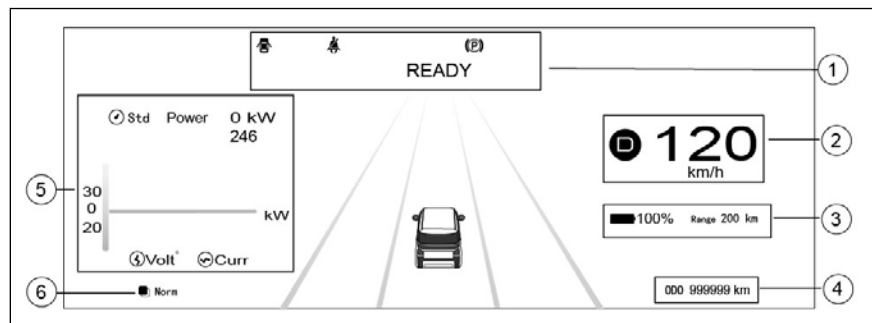

Type 2 *

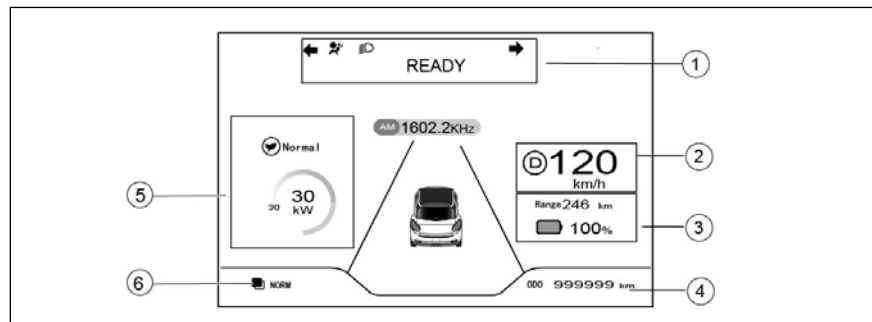

Vehicle Parameter Display and Setting Control Buttons*

These buttons control the display of the vehicle parameters you want to know and select some vehicle settings that can be made.

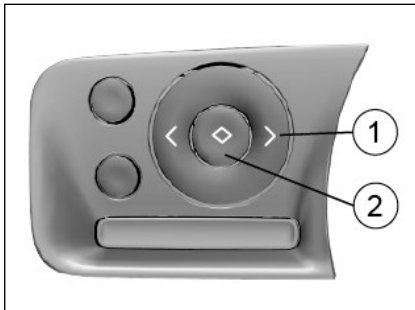

1. Left/Right buttons to switch the setting menu on the instrument panel and display vehicle parameters.
2. OK button to access the vehicle settings menu on the instrument panel and select from the settings.

Volume Control Buttons on the Steering Wheel

These buttons control the audio system, Bluetooth phone, multimedia system, and WIND*.

Type 1 *

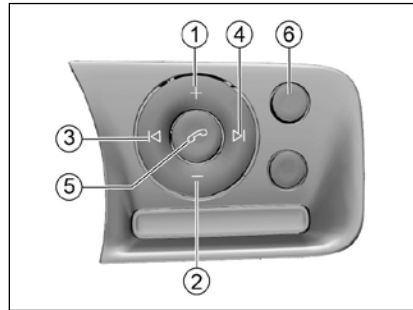

1. Volume Increase (+)
2. Volume Decrease (-)
3. Previous song/ station
4. Next song/ station
5. BT connection/ call answer & decline
6. Media source change and Mute (*)

Type 2 *

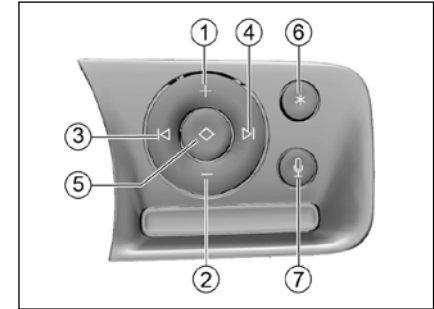

1. Volume Increase (+)
2. Volume Decrease (-)
3. Previous song/ station
4. Next song/ station
5. Call answer & decline
6. Customizable button (*)
7. Voice Recognition prompt

Instrument Panel Indicator

When the ignition switch is at the ON position, most of the control indicators will light up briefly as a function test.

Meaning of control indicator color:

Red = danger, important warning

Yellow = warning, information, fault

Green = confirmation on

Blue = confirmation on

Turn Direction / Hazard Warning

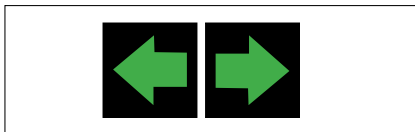

When the turning signal lamp flashes, the direction indicator lamp on the corresponding side also flashes. If the hazard warning lamps are operated, both direction indicator lamps will flash together. If either direction indicator lamp in the instrument pack flashes very rapidly, it indicates that the turning signal light on the corresponding side has failed.

Door Open Warning



It is indicated that the door is open or not closed tightly.

12V Battery Charging Fault Indication

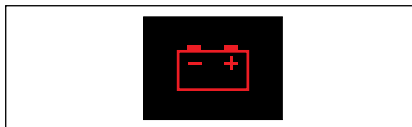

If this lamp illuminates after starting the vehicle, it indicates that the low-voltage battery charging system has failed. If this lamp flashes, it indicates that the battery power is low, and a prompt message appears in the instrument pack. At this time, the system will restrict or turn off some electrical devices. Please start the vehicle immediately to charge the battery.

Low Beam Indication

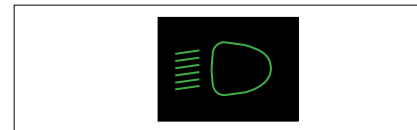

The headlamp low beam is turned on.

High Beam Indication

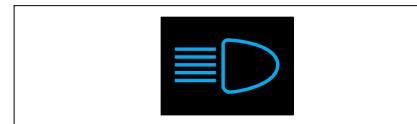

The headlamp high beam is turned on.

Position Lights



The side lamps are on.

ABS Indication

The ABS has failed.

If an ABS failure occurs while driving, ABS operation will be suspended, but normal braking will still be available.

EPS Indication

If this lamp illuminates, it indicates that the electric power steering system has a general failure and the performance is reduced. Please stop the vehicle as soon as safety permits. If the lamp still illuminates after restarting the vehicle and driving for a short while, please contact a local MG Authorised Repairer for service immediately. If this lamp flashes, it indicates the electric steering column lock has a failure. Please stop the vehicle as soon as safety permits, and turn off the START/STOP Switch.

If this lamp extinguishes after flashing for a while, it indicates that the steering wheel is locked. Please attempt to release the lock by rocking the steering wheel left to right.

Airbag Fault Indication

It indicates that the SRS or the seat belt has failed. As soon as conditions permit, safely stop the vehicle and switch the vehicle power system to the OFF position and contact an MG Authorised Repairer immediately. An SRS or seat belt fault may mean the components may not be deployed in the event of an accident.

Handbrake Indication

The brake system has failed. Please stop the vehicle as soon as safety permits, and turn off the START/STOP Switch.

Anti-theft Authentication Indicator

This indicator illuminates when the door is opened. It goes out after the engine is started.

Seat Belt Unfastened

If this lamp illuminates or flashes, it indicates that the seat belt for the driver or passenger* remains unfastened.

Tire Pressure Failure Indication

If this warning lamp illuminates, it indicates that a tyre pressure is low. Please check the tyre pressures. If this lamp flashes first and then

remains illuminated after a period of time, it indicates the system has detected a fault.

EPB Status Indicator Lamp*



If this lamp illuminates, it indicates that the EPB is enabled.

If this lamp flashes, it indicates that the vehicle is parked on an excessive slope or the EPB system has failed. Please securely park the vehicle on a safe road.

Electronic Parking Brake (EPB) System Malfunction Warning*



The EPB system has detected a fault.

AVH- Status Indicator Lamp*



This indicator illuminates when the AVH function works and the vehicle is being parked.

AVH Fault Warning Lamp*



In case of an AVH function module fault or a warning lamp fault, it will be indicated in any of the following ways:

- The lamp does not illuminate when the ignition switch is turned on.
- The lamp does not go out after it illuminates.
- The lamp illuminates during driving.

Once the AVH fault warning lamp shows the above abnormalities, contact your dealer immediately.

ESC Fault Warning Light*



If this lamp illuminates, it indicates that the stability control system or traction control system has failed.

If this lamp flashes while driving, it indicates that the system is operating to assist the driver.

Stability Control / Traction Control System OFF Warning*



The stability control / traction control system is switched off manually.

READY Indicator

The vehicle is ready for driving.

Charging Status Indication

When the vehicle is connected to an external power supply for charging, this lamp will illuminate and extinguish after charging is completed.

Charging Cable Connection Indication

The vehicle is connected to a charge point.

Energy Recovery Indication

The vehicle is recycling energy.

EVP Fault Indication

If the EVP warning light illuminates in below ways, it indicates the EVP fault has occurred:

- EVP light does not illuminate when ignition turns on;
- EVP light keeps illuminating and doesn't go off after several seconds of ignition turning on;
- EVP light flashes when driving;
- EVP light illuminates when driving;

When EVP fault occurs, it will be less brake vacuum assistant, and you will feel the brake pedal is hard to press down or need

more force to press down. If EVP fault is confirmed, must drive very carefully in low and safe speed, and see your dealer as soon as possible. If you are not sure if the car is safe to drive, call your dealer for assistant.

Precaution

If EVP warning light illuminates when driving, have your car inspected by nearest dealer as soon as possible otherwise, it is at high risk of causing an accident due to brake control reduction.

Drive Power Limit Indication

The vehicle power has been reduced.

Motor Overheating Indication

It indicates that the motor has overheated.

Do not continue driving the vehicle. Please stop in a safe area as soon as possible to cool down the motor.

Insulation Fault Indication

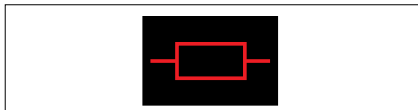

It indicates that the vehicle is in danger of electric leakage. Please contact a local MG Authorised Repairer for service immediately.

Front Hatch Open Indication



When the front hatch is open or not closed tightly, the warning lamp lights up.

Co-pilot Seat Belt Not Fastened Indication



The seat belt warning lamp illuminates if the passenger does not fasten the seat belt properly after the ignition switch is turned on. The following circumstances will appear unless the driver fastens the seat belt properly.

- The seat belt warning lamp keeps illuminated.
- If the vehicle speed exceeds 20 km/h, the warning lamp will flash and the warning buzzer will buzz for a certain time.

Power Battery Thermal Runaway Indication



If the warning lamp lights up, a buzzing alarm sounds in the vehicle and a text message appears on the instrument that says “Vehicle is at risk of fire, exit as soon as possible”. This means the traction battery is overheating and the vehicle is at risk of fire. You should pull over as soon as possible, get out of the vehicle when it stops, withdraw to a safe area and call for help.

Vehicle Fault Indication



When the power supply switch is in the ACC position, the warning lamp will be on, and the READY lamp will light up and then go out. This indicates that the powertrain is normal.

- In case of the following circumstances, please consult the nearest Aftersales Service Center for inspection:.
- This indicator lamp does not illuminate when the power switch is turned to “ACC”.
- The lamp does not go out after it illuminates
- The warning lamp illuminates, the “READY” indicator lamp turns off, and the vehicle cannot run.

Power Battery Pack Heating Indication

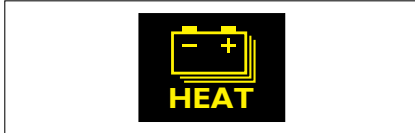

This battery pack heating indicator lamp will illuminate when the vehicle is charged at a low temperature, indicating that the system heats the battery to keep it charged at a safe and reliable temperature.

When the vehicle is fully charged, but the charging power is not disconnected in a low temperature environment, the battery pack heating indicator lamp will also illuminate, indicating that the system continues to heat the battery rapidly, so that the battery can reach an ideal temperature in the operating environment.

This lamp is a state indicator lamp, not an MIL. It has no influence on driving and will not illuminate during driving. If it illuminates during driving, please contact the nearest MG Authorised Repairer.

Tailgate Open Warning Lamp



When the tailgate is open or not closed tightly, the warning lamp lights up.

Low High-Voltage Battery Soc Warning Light

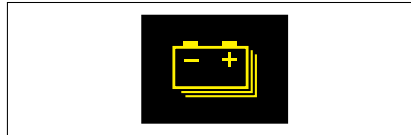

If this lamp illuminates or flashes, it indicates that the high voltage battery charge is low. Where possible please charge the high voltage battery.

Rear Fog Indication

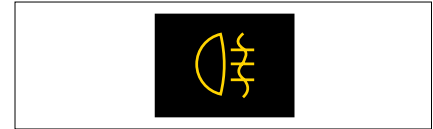

This indicator illuminates when the rear fog lamp is turned on.

Notes:

ABS: anti-lock brake system

EPS: electronic power steering system

EBD: electronic brakeforce distribution system

EPB: electronic parking brake

AVH: automatic vehicle hold

ESC: electronic stability control system

TPMS: tire pressure monitoring system

You can learn more about each warning lamp through "My MG app".

Lighting

Hazard Warning Lamp



Press  to turn on/off the hazard flasher.

Headlamp Leveling*

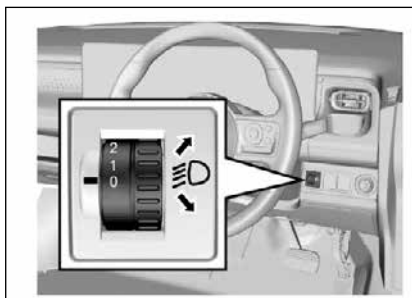

The headlamp leveling knob is located at the right side of the instrument panel.

Please adapt the headlamp illuminating range to the vehicle load so as to acquire the best lighting effect and avoid dazzling. Turn the knob to the desired position:

0 = front seats occupied

1 = all seats occupied

2 = all seats occupied with the trunk loaded

3 = driver's seat occupied with the trunk loaded

Follow Me Home*

When the vehicle is turned off, turn the ignition switch to ACC or LOCK, or turn off the headlamp after pulling out the key, and turn the lighting switch control lever toward the steering wheel twice to trigger "Follow Me Home" (The light is delayed off). At this time, if remote locking occurs, the low-beam lamp will automatically turn off after a 1-minute delay (The automatic turning off time* can be set on the on-board host.). If the vehicle is not remotely locked, the low beam will turn off automatically 10min later.

Lamp ON Reminder*

If the ignition switch is turned to the LOCK position or the lighting switch is not turned to the OFF position after the key is pulled out, an audible prompt will be given when the driver-side door is opened. The alarm sound stops after the lamp is turned off.

Lighting Switches



To switch on or off the headlamp, tail lamp and parking lamp, please turn the end of the combination switch control lever.

The light switch has 3 positions and they represent different lighting functions:

OFF = All the lamps are turned off.

☞☞ = The position lamp, license plate lamp, instrument panel lamp and backlighting lamp of all panels will turn on.

☞○ = The low beam lamp and all lamps mentioned above will turn on under the precondition that the ignition switch is turned to ON position.

High Beam



To switch on the headlamp high beam:

Ensure that the ignition switch is in ON position.

The headlamp is in the low beam state.

As shown in the figure, push the combination switch control lever towards the instrument panel.

The headlamp high beam indicator will turn on when the headlamp high beam is turned on. To switch from headlamp high beam to low beam, pull the control lever towards the opposite direction until it returns to the normal position.

Warning

When approaching the on-coming vehicle or the vehicle ahead, please do not switch the high beam to low beam. This is because headlamp high beam will temporarily blind other drivers, resulting in a collision.

Headlamp Flashing

To activate headlamp high beam flashing, please pull the combination switch control lever toward steering wheel and then release it. The control lever will return to the normal position.

Before releasing the control lever, keep the headlamp high beam on.

Turn and Lane Change Signal Lamp

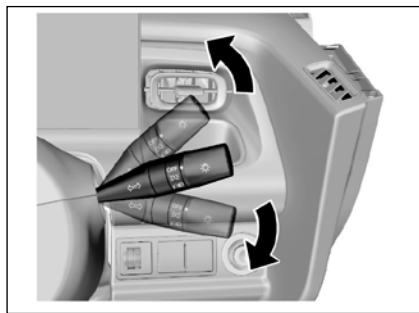

To turn on the turn and lane change signal lamp, the ignition switch must be in ON position.

Control lever upward = left turn signal lamp.
Control lever downward = right turn signal lamp.

After cornering, the turn signal stops automatically and the control lever returns to the normal position.

To change the lane, pull the control lever upward or downward to half position of that of turn signal lamp (not reaching the turn signal lamp position) and hold it. After lane change, release the control lever and it will return to the normal position automatically.

Rear Fog Lamp

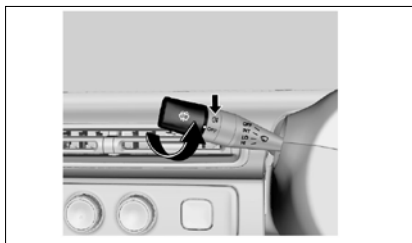

When the low beam of the headlamp is turned on, the rear fog lamp can be turned on by rotating the fog lamp switch on the wiper operating lever.

When the rear fog lamp is turned on, the rear fog lamp indicator on the instrument cluster will turn on.

The rear fog lamp can be turned off by rotating the switch again.

Daytime Running Lamp*

After the vehicle is started, the daytime running lamp will be turned ON when the position lamp is turned to ON position.

The Day time running light will go off, when the lighting combination switch control lever is set to OFF condition. When the turn signal

is on, the occupied daytime running lamp will automatically turn off.

Temperature Control System

A/C control panel

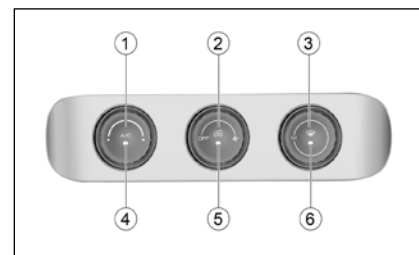

1. Temperature control knob
2. Fan control knob
3. Ventilation mode distribution knob
4. A/C button
5. Inner/outer circulation button
6. Defroster Button

Note: The A/C settings can be viewed through the on-board host/instrument panel display.

Driving and Controls

Trial Run of New Vehicle

Following measures can be taken within the initial mileage of 500 km, which can improve the performance, promote the vehicle economy and extend the service life:

- Avoid any emergency shutdown except in an emergency. With this, the brake can run in well.
- Try not to accelerate the vehicle sharply or drive at a high speed to avoid motor damage and save power.
- Do not tow any other vehicle with your vehicle.

START/STOP Button*

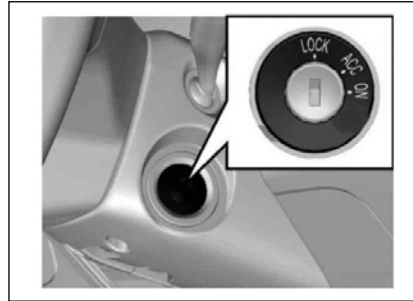

The power switch is located below the right side of the steering wheel and has the following working positions: LOCK, ACC and ON.

- **LOCK**

This position is for power turning off and steering wheel locking. Only when you turn the power switch to this position can you pull out the key.

Lock the steering wheel. Remove the key and turn the steering wheel till the steering wheel is locked.

If you cannot turn the key when unlocking the steering wheel, you can gently turn the steering wheel to right/left for one thing and turn the key for another.

- **ACC**

This position is for power-on of some electrical equipment, such as the audio system. The instrument panel illuminates when the power switch is turned to this position.

When the key is turned to ACC, check whether the warning lamps and indicators on the instrument panel are on and off normally.

Notes

Do not keep the key at “ACC” for a long time. Otherwise, the power of 12V battery may be excessively consumed.

- **ON**

This position is for power on of all electrical accessories except HV electrical appliances. Only the power switch is at the “ON” position can the vehicle enter the READY state.

Notes

If it is not necessary to start the vehicle, please do not keep the key at “ON” for a long time. Otherwise, the 12V battery may be excessively consumed.

“READY” State (Start State)

When the vehicle enters the “READY” state, all the HV working circuits will be turned on, and the driving motor will be ready to drive in gear. The “READY” state is similar to the starting state of an internal combustion engine vehicle.

Only when the vehicle enters the “READY” state can you engage the gear and turn on the A/C for cooling or heating.

How to Enter “READY” State:

1. Turn the power switch to “ON” first.
2. Then press the brake pedal until the READY indicator on the instrument panel illuminates.

After entering the READY state, the vehicle will remain in this state until you turn off the power switch to “ACC” or “LOCK”.

For keyless models, press the brake pedal gently twice to enter the READY state.

How to Exit “READY” State:

Turn off the power switch to “ACC” or “LOCK”. After the vehicle exits from the “READY” state, the driving motor will exit from the working state, and the vehicle cannot be engaged in gear or run.

For keyless models, you can lock the vehicle after getting off, and the whole system will be turned off. Or you can press the OFF button below the steering wheel to exit.

Notes

Do not use emergency button excessively. Use only in case of emergency.

Preparation Before Entering “READY” State:

- Check that the hand brake has been pulled.
- Ensure that no barriers exist around the vehicle.
- Ensure that all windows and doors are clean and transparent.
- Check whether the tire conditions and the inflation pressure are proper and whether foreign matters exist.
- Ensure that seats and rearview mirrors are at proper positions. Adjust them if necessary.
- Fasten the seat belt and ask passengers to fasten seat belts.
- Release the hand brake before the vehicle starts.

If Vehicle Cannot Enter “READY” State

If the READY indicator on the instrument panel does not illuminate, it indicates that the vehicle has not entered the READY state. Please check whether the power switch is at the “ON” position and whether the brake pedal has been pressed.

If there is no display on the instrument panel when the power switch is at the “ON” or “ACC” position, the 12V battery may not have insufficient power. Therefore, charge the 12V battery first. It is suggested to contact the Aftersales Service Center for solution.

Notes

If the vehicle is not at the “READY” state, please do not use the audio system, lamps, A/C or other electrical equipment for a long time. When leaving the vehicle, please also shut down the electric equipment. Otherwise, the 12V battery will run out, causing the instrument panel unable to display and the vehicle will not enter the READY state.

Parking

- Before getting off the vehicle, pull handbrake&turn the power switch to “LOCK” and pull out the key. Turn the steering wheel till the steering wheel is locked.
- When parking on a ramp, pull the parking brake as tightly as possible, while pressing the brake pedal.
- When parking the vehicle on one uphill ramp, turn the front wheels away from the road shoulder. When parking the vehicle on one downhill ramp, turn the front wheels towards the road shoulder.

Precaution

Do not park and drive the vehicle on inflammable such as straw and hay. If such inflammables cannot be avoided, park the vehicle to check and confirm that these inflammables are not attached at the chassis after the vehicle passes the inflammables.

Otherwise, these inflammables may be ignited by high-temperature components on the chassis, and thus a fire accident can be caused.

HHC*

When the vehicle is in D gear or R gear at the half-slope start, after releasing the handbrake and brake pedal, the hill hold control function will be activated when the vehicle slides slightly, which can keep the vehicle parked on the slope for about 3-5 seconds. During this period of time, the vehicle will not slide, and the driver will be given a starting time to assist in climbing.

Precaution

During the 3-5 seconds when HHC is activated, in case of any one of the following conditions, HHC will automatically exit:

1. No operation is carried out by the driver. In this case, the hill hold control function will automatically exit after 3-5 seconds.
2. The driver shifts gears (to N or P, or D/R). In this case, the hill hold control function will automatically exit.
3. The accelerator pedal is depressed to start the vehicle and automatically exit the HHC.

Precaution

When HHC is disabled, it will be activated again by one of the following operations:

1. When the driver depresses the brake pedal or pulls the handbrake to stop the vehicle, the hill hold control function will be activated again. Releasing the handbrake and brake pedal will cause the vehicle to slide slightly.
2. After the accelerator pedal is depressed to start, if the vehicle stops and slides slightly, HHC will be activated again.

Precaution

1. In case of low battery (<25%) or low ambient temperature (<-10°C), hill hold control power decreases or there is no power output. In such a case, please drive cautiously.
2. If the motor temperature is too high (the instrument will prompt) after continuous or frequent use of the hill hold control function, please pay attention to cooling the vehicle.
3. The greater the slope, the longer the sliding distance. Overloading may lengthen this distance. Therefore, please do not overload your car.
4. Do not rely too much on HHC as it cannot replace the functions of brake and handbrake. Please drive carefully. The Company is not responsible for any consequences arising from reliance on this system.

Gearshift Knob

Turn the knob to shift gears according to the marks on the knob.

You can see the current gear in the gear display area on the instrument panel. The backlight of the corresponding gear position on the knob will also go on.

Only in the READY state can you drive in gear. When engaging in D or R position, you must first depress the brake pedal; otherwise you cannot engage into gear.

-  : Charge
- R : Reverse
- N : Neutral
- D : Drive

The vehicle is equipped with economy, normal and sports driving modes. Press the E/S button on the instrument panel to change the driving mode. The driving mode will affect the acceleration performance. Under the economy mode, the vehicle speed will be limited to 80 km/h.

Notes

Do not allow children to operate the gearshift knob to avoid accidental start of the vehicle.

Notes

When the gear position is in R, if the gearshift knob continues to be turned left, the gear position remains in R. When the gear position is in D, if the knob continues to be turned right, the gear position remains in D.

Anti-lock Brake System (ABS)

As one advanced electric braking system, the anti-lock brake system (ABS) is helpful in avoiding the vehicle from slipping and losing control, and this system can also provide the maximum braking capability on the slipped pavement.

When the ignition switch is turned on, the ABS warning lamp illuminates momentarily. The ABS warning lamp does not go out or illuminates when the vehicle is running, it indicates that the ABS is faulty. Please immediately contact the MG Authorized Service center. Refer to “ABS Fault Warning Lamp” under Chapter “Instruments and Controls”.

The ABS will monitor the speed of each wheel during braking. If one wheel tends to be locked, the system will control brakes of two front wheels and two rear wheels respectively. When the ABS works, the brake pedal often vibrates slightly with noise.

Electric Brake Force Distribution (EBD) System

The EBD system uses the high-speed computer to respectively induce and calculate different ground to which four tires are attached, and thus calculate different friction values at the moment the vehicle brakes. Therefore, the four tires can brake in different ways using different forces based on the conditions, and the ways and forces can be adjusted quickly during movement, so as to ensure that the vehicle is stable and safe.

Electronic Stability Control (ESC) System*

The ESC system is a new type of active safety system, which represents the further development of anti-lock brake system (ABS) and traction control system (TCS) functions. In addition, the system also adds a yaw rate sensor, a lateral acceleration sensor, and a steering wheel angle sensor. The front and rear driving force, braking force, and left and right wheels are controlled by ECU to ensure the lateral stability of the vehicle. The ESC system will automatically intervene when the driver drives at excessive speed or turns at high speed to ensure that the vehicle is under control again and safe. Indicators related to the ESC system include the ABS fault warning lamp, the EBD fault warning lamp, the ESC fault warning lamp, and the ESC off indicator.

1. After the ignition switch is turned on, the indicator lights up for self-inspection. If the four indicators are on for 3s, it indicates that the ESC system is conducting self-inspection and the indicators work normally. Under normal circumstances, all four indicators go out after 3 seconds. When the ESC system fails (such as improper installation, loose connector,

and abnormal CAN communication), only the ESC off indicator will go out and the other 3 indicators will be on after 3s.

2. If the ESC function is activated during driving, the ESC indicator will flash to remind the owner that the ESC system is running. If the ESC system cannot work normally when the ABS and EBD systems work normally, the ESC MIL will be on, indicating that the ESC system fails. If the ESC system and ABS system fail while the EBD system works normally, the ESC MIL and ABS MIL will be on. If the ESC system, the ABS system, and the EBD system fail, the ESC, ABS, and EBD fault warning lamps will light up.
3. The ESC off indicator is to indicate that the ESC function is turned off (the indicator is on when the ESC function is off, and off when the ESC function is on). If the owner presses the ESC off button, some ESC functions will be off and the ESC off indicator will light up. When the ESC switch is pressed, the ESC system starts to work, and the ESC function will not be disabled immediately but after the process is completed. If the owner presses the ESC switch again, the

ESC function will be enabled again. If the ESC switch is pressed for more than 10 seconds, the ESC system will consider it as a misoperation (For example, the ESC switch is accidentally pressed by other objects) and will not turn off the ESC function.

4. The ESC system will be activated automatically after every re-ignition.

Turn off the ESC System*

The ESC function can be turned off by accessing the vehicle settings menu on the host. When the ESC function is turned off, the ESC off indicator lights up. It is generally not recommended to shut down the ESC system. The ESC system can be turned off temporarily only when the vehicle just leaves muddy ground or climbs a slope in a slippery area.

Parking Brake

Parking Brake



The parking brake impacts rear wheels.

The parking brake lever is between two front-row seats. To operate the parking brake, stop the vehicle, press the brake pedal and pull the parking brake lever.

To release the parking brake:

1. Press the brake pedal.
2. Pull back on the parking brake lever slightly .
3. Press the button on the parking brake lever joint .
4. Release the parking brake lever when holding the button.

Electronic Parking Brake (EPB) *



The parking brake impacts rear wheels.

As shown in the figure above, the electronic parking brake (EPB) switch is between two front-row seats.

Manually Activate The Parking Brake

To apply the parking brake, depress the brake pedal to stop the vehicle, and pull up the EPB switch. Release the EPB switch after the EPB working indicator lights up and (P) the instrument panel displays “Parking Brake Working”.

At this time, the EPB system clamps the vehicle to park.

Manually Release the Parking Brake

If the parking brake must be released, first make sure that the ignition switch is at the ON position, depress the brake pedal, and then press the EPB switch. The EPB working indicator goes out, and the instrument panel displays “Parking Brake Released” to remind you that the parking brake has been released.

If the brake pedal is not depressed, the instrument will command “please depress the brake pedal and then release the EPB switch”.

When the EPB switch is operated, the switch will respond only when it is released or pressed for more than 0.1s.

Deactivation of Automatic Clamping Function

When pushing, towing, and cleaning the vehicle, you may need to turn off the EPB automatic clamping function to drive the vehicle after startup.

Turn-off method: Depress the brake pedal and hold the EPB switch pressed while stopping the vehicle. Try to push the vehicle to confirm that EPB is not in the clamped state.

Automatic Vehicle Hold (AVH)*

The vehicle with EPB has the auto vehicle hold function.

After the function is activated, the driver can depress the brake pedal to stop the vehicle, or depress the brake pedal to make the vehicle stand still and idle. After the brake pedal is released, the hydraulic pressure in the brake system will keep parking (whether on uphill or flat roads). At this time, the vehicle can be stationary without pulling up the EPB switch.

If the driver depresses the accelerator to start the vehicle within 5 minutes, the hydraulic pressure in the brake system will be automatically released, and the parking brake will be released at the same time to start

the vehicle. After 5 minutes, automatically switch to the electronic parking brake caliper, clamp the parking, and release the hydraulic pressure in the brake system at the same time.

The start/stop state of the auto vehicle hold function can be saved. If the auto vehicle hold switch is ON or OFF when the power supply is turned off last time, it will remain the same when the power supply is turned on again.

Automatic Vehicle Hold (AVH) Switch*



After the vehicle enters the READY state, the driver fastens the seat belt, closes the driver's side door, and presses the auto vehicle hold switch. At this time, the background lamp on the switch illuminates, and the auto vehicle hold function is activated.

After that, if the conditions are met, the auto vehicle hold function working indicator on the instrument panel will light up. The parking brake starts to work, and the brake system applies braking force to park the vehicle.

Electric Power Steering (EPS) System

The EPS system provides the steering assist for the vehicle.

The power steering fluid is not required for the system, which brings great convenience for the daily vehicle maintenance.

When the ignition switch is connected, the EPS fault warning lamp illuminates momentarily. The EPS fault warning lamp stays on or illuminates when the vehicle is running, it indicates the EPS system is faulty. In this case, you need immediately go to Aftersales Service Center for maintenance.

When the EPS system is under extreme conditions of high load work for a long time (For example, the steering wheel is “turned to the end” for a long time, or the vehicle is moved into the garage at low speed repeatedly to a wide angle), the thermal protection function may be activated due to excessively high temperature of electrical elements.

The system will reduce the power assist after it enters the thermal protection state, and at the time you have to steer the wheel with great force. If the normal power assist need be recovered, you can steer the wheel at a smaller angle or promote the vehicle speed. You can restart the vehicle when necessary.

Low Speed Pedestrian Warning System*

BEV has less noise during driving, and thus the lowspeed pedestrian warning system onboard can play a good role in pedestrian alerting.

When the vehicle runs at a speed of 0 ~ 30 km/h or backs up, the warning system is working. The vehicle’s pedestrian warning device will make a buzzing sound similar to that of the engine or a beeping sound similar to that of the reversing sensor.

Notes

The warning sound volume of the low-speed pedestrian warning device is gradual. When the vehicle speed is close to 0 or 30 km/h, the sound will be the minimum, and when the vehicle speed is 15–20 km/h, the warning sound will reach the maximum.

Notes

Battery electric vehicle has less noise during driving, and thus the low-speed pedestrian warning system on-board can play a good role in pedestrian alerting. Only when there are no pedestrians in a short distance and the surrounding environment obviously does not require a warning tone can the system be disabled.

Energy Recovery System

When the vehicle power is below 96% and the vehicle speed is high, release the accelerator pedal or step on the brake pedal, and when the system judges that the conditions for energy recovery are met, the vehicle will recover energy. The mechanical energy during driving will be converted into electric energy and then stored in the traction battery to increase the endurance mileage.

When the energy recovery system is working, the traction battery and wheel symbols in the car image on the left side of the instrument panel display green, the power is displayed as negative, and the energy recovery indicator goes on.

Limitations of energy recovery:

1. No energy recovery is required when the vehicle power is more than 95%.
2. No energy recovery is required below 0°C.
3. When ABS or ESC* fails, energy recovery will not be carried out.

4. In “S” (Sports) mode, no energy recovery is available at a vehicle speed less than 5 km/h. In “E” (“Economy”) mode and standard mode, no energy recovery is available at a speed less than 8 km/h.

Under some other conditions other than the above, the energy recovery indicator on the instrument panel may not light up, but there is still energy recovery. In this case, the energy recovery power is small.

E/S Button

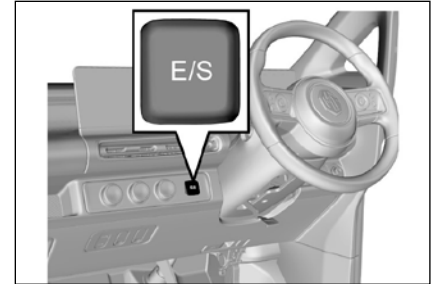

1. Long press E/S button (~3s) to switch energy recovery level – light, normal & heavy. If equipped, it can be set from the infotainment screen also.
2. Gently press E/S button to switch driving modes – ECO, NORMAL & SPORT.

Charging Specification

Methods of Determining Whether a Vehicle Needs Charging

1. If conditions permit, it is recommended that you charge the vehicle when parking it. Shallow charge and discharge is conducive to prolonging the battery life. Do not wait until the battery runs out before recharging, which may not be conducive to your next trip and the battery life.
2. If the SOC low warning light goes on during driving, it indicates that the traction battery pack is low in power and needs to be charged as soon as possible.
3. When the electricity meter indicates low remaining power, or the endurance mileage cannot meet the travel demand, charging is required.

Requirement for Charging Power Supply

1. The general household AC power supply is used for the charging system of this vehicle:

Voltage: 230V; current $\geq 16A$; power $> 3.6KW$.

Please ensure that the load of the power supply line meets the above requirements. If the supply line is formed by connecting multiple lines, the wires, plugs and sockets on each line must meet the load requirements. Otherwise, the part that cannot meet the load requirements may melt or catch fire due to overheating.

2. When the household power supply is used for charging, the main switch and leakage protection switch should be installed at the front end of the charging line, so that the main switch can be disconnected and leakage protection can be carried out in an emergency. Ground wire must be grounded properly.
3. Be sure to select high-quality cables and sockets, and ask a professional electrician to install supply lines and equipment for you.

Notes

When the AC charger plug provided by the vehicle is used for charging, the charging power is less than 6.6KW. If the vehicle is equipped with a 6.6KW or 3.3KW on-board charger, the charging power can reach 6.6KW or 3.3KW only when the high-power AC charging pile is used for charging.

Precaution

Be sure to ask a professional electrician to install the charging line for you; otherwise it may cause fire or electric shock.

Check Before Charging:

1. Check that the handbrake is pulled on completely and the key is placed in LOCK position or removed.
2. Do not ride in the vehicle when charging. Ensure the ventilation of charging places, and do not charge in confined and narrow spaces.
3. Before charging, please check whether the skin and casing of the charging cable are broken. If so, please contact the service center for repair or replacement. Make sure that the charging cable is in a state of natural extension, and do not hang in the air.
4. During charging, appropriate protective measures should be taken to avoid children and other irrelevant personnel approaching the charging vehicle and charging cable.
5. During charging, it should be noted that there should be no residual rainwater in the charging socket and its vicinity.
6. Do not charge the vehicle in an environment where there is rain, snow or accumulated water, or fire source nearby. Also, do not charge it in thunder weather. In case of rain, snow, water rising, or strong wind during charging, stop charging and put away the charging cable. Otherwise, there is risk of electric leakage.
7. If the vicinity of the charging port gets wet during charging, please pull out the charging plug from the power supply socket and then unplug the charging gun from the charging port while ensuring safety. If necessary, please use insulating gloves and contact the service center for testing and confirmation as soon as possible.
8. When touching the charging plug, please keep your hands dry, and use insulating gloves if necessary.
9. The ambient temperature of charging is recommended to be between 0°C and 35°C, and avoid charging at low or high temperature (it is recommended to charge the vehicle at noon in winter, and in the morning or evening in summer). Avoid charging in an environment of high temperature such as direct sunlight.
10. The charging plug is a high-voltage electrical device, which is strictly prohibited for children. Children are strictly forbidden to operate during charging. If there are many children or people walking frequently in the charging area, safety signs should be set up.
11. Lock the doors before leaving the vehicle to prevent theft.

Precaution

Before charging, check the charging cable and charging port to make sure that the cable is not damaged and that no water or foreign matter enters the charging gun and port.

Precautions

1. In order to extend the service life of the traction battery pack and ensure the driving safety, avoid parking & Driving when the battery power is too low (< 10%).
2. Do not use the traction battery pack onboard for other purposes.
3. Improper handling of the traction battery may cause serious accidents, such as battery damage or personal injury. Note the following to avoid accidents:
 - Do not expose the vehicle to the environment above 45°C for more than 24 hours, and place the vehicle in a cool environment in time. Avoid parking & charging vehicle under direct Sun light & Direct Rain.
 - Do not place the vehicle in an environment of -25°C for more than 7 days, and place the vehicle in a warm environment in time. If the vehicle is in a low-temperature environment (below -25°C) for a long time, the traction battery pack may freeze inside, resulting in failure to charge and provide driving power to the vehicle, which is very dangerous.
4. To increase the service life and safety of battery packs, we provide these suggestions:
 - The vehicle without a traction battery heating system cannot be charged when the internal temperature of the traction battery is below 0°C. Therefore, at a low ambient temperature, please charge the vehicle as soon as possible within one hour after parking. If the vehicle cannot be charged due to the low temperature of the traction battery, move the vehicle to a warm place or drive for a period of time before charging.
 - Vehicle is not to be used for long duration (more than 3 months) and is in parked condition, ensure the SOC is above 40%. Charge vehicle till 100% SOC before driving.
 - Please try to avoid sharp acceleration or deceleration during driving.

Notes

If vehicle is not to be used for long duration (more than 3 months) and is in parked condition, ensure the SOC is above 40%. Charge vehicle till 100% SOC before driving. Ideal condition to park vehicle for longer duration is with SOC between 50% to 60%.

Notes

The traction batteries are special chemical products that need proper use and maintenance. Routine full charge and slow discharge are critical to the maintenance of their performance. In addition, the traction battery capacity is subject to natural attenuation due to the chemical properties. When you find a decrease in SOC range, it is recommended to check it at the service center. If the battery consistency is turned out to be within the normal range, this decrease is due to the normal attenuation of the battery capacity.

Charge Operation and Precautions

Preparations:

1. Turn off the power, pull out the key and pull up the handbrake.
2. Take out the charging cable from the trunk and check whether it is in good condition.

Charging with AC Supply:

1. Open the vehicle charging port.



As shown in the figure, press the right side of MG logo to make the charging port door pop open

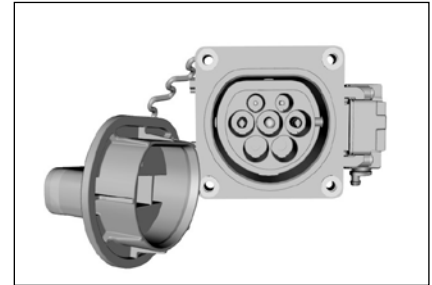

Open the charging cap, as shown in the figure.

2. Insert the plug into the power socket.

Insert the plug into a 230V ($\geq 16A$) grounded household AC power socket. Please select a socket with power > 3.6 KW and use it exclusively for charging.

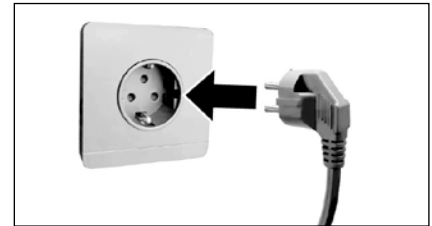

3. Insert the charger plug into the charging port.

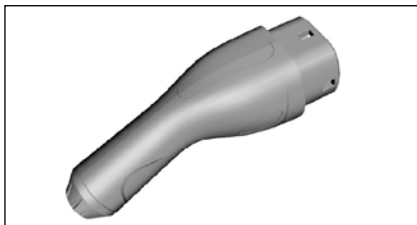

Remove the charger plug cap.

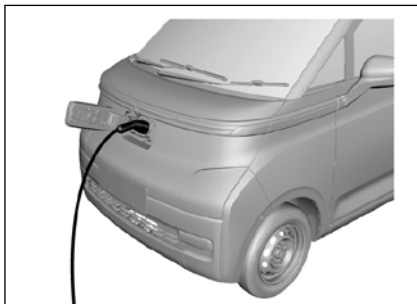

Insert the charger plug into the charging port until you hear a “click”.

Insert the charging gun correctly, and then the green indicator light flashes.

- 1) Green light 1 -first green light is for POWER ON and it will continuously remains ON while charging
- 2) Green light 2 (center)- will blink (in green color) during charging, will remain ON when SOC reaches 100%.
- 3) Red light- for malfunctioning During charging, the green indicator light flashes. In case of any malfunction, the red indicator light is always on or flashing.
- 4) Pull out the charger plug after charging. Switch off the supply, pull out the charging gun and fit the charging gun cover, charging cap and charging port door in place.

Precaution

Do not try to remove the charging gun when charging is ON. If it is necessary to interrupt the charging of the vehicle, isolate the power supply first, then disconnect the vehicle plug.

Smart Charging

The 12V battery SOC is constantly monitored, when the Start/Stop switch is in the OFF position it is possible, under certain conditions, that the HV battery will automatically charge the 12V battery to ensure the vehicle starts. This function will activate and switch off automatically.

Notes

The system will suspend intelligent charging if a fault is present, when starting or the vehicle is being charged by an external device.

Notes

The driving range will be reduced after intelligent charging.

Notes

The intelligent charging function is suspended when the high voltage battery is in a low SOC.

Charging Precautions

1. Park the vehicle in a ventilated place. Do not stay in the vehicle.
2. In case of a power outage during charging at home, the charging system will continue to charge the vehicle after power restoration.
3. When charging at the charging station, follow its operation requirements and wait in a safe area.
4. Before driving, make sure that the charging gun is pulled out, the charging cable is put away, and the charging port is closed.
5. It is normal that the predicted time to full charge may vary to some extent with different ambient temperatures and power capacities. At a low ambient temperature, the charging efficiency decreases and the charging time is extended

Danger

Before charging, check the charging port and the connector port of the charging plug for any water or foreign matter. If any, charging is not allowed. Otherwise, it may lead to short circuit or electric shock, resulting in personal injury and property loss. Do not touch the metal parts of plugs and other connectors when charging.

Water conducts electricity. During charging, do not touch the charging cable and plug with wet hands, and do not charge the vehicle in a wet place; otherwise you may get an electric shock.

Danger

In case of any abnormal smell or smoke during charging, stop charging immediately and contact the service center in time.

Do not charge the vehicle in thunder and lightning conditions, or in the open air in rainy days. Otherwise, it may damage the charging equipment, or cause lightning strike and electric shock.

Emergency Power Off*

If the vehicle is equipped with an emergency power-off button, this button can be used to cut off the power supply in an emergency.

When the vehicle speed is less than 2 km/h, press this button to shut down the vehicle immediately. When the vehicle speed exceeds 2 km/h, press this button for 5s or 3 consecutive times within 2s, and the power supply will be switched to ACC state. When the vehicle speed is less than 2 km/h, the state will be switched from ACC to OFF.

TPMS

The TPMS indicator illuminates when the vehicle tire pressure is low. When the TPMS fails, the indicator will flash for 60 seconds and then is normally on.

The vehicle is equipped with an indirect TPMS. After each inflation to adjust the tire pressure or replace the tire, the TPMS (ordinary type) must be reset by pressing the TPMS button on the right side of the instrument panel for 2s. For intelligent type, you can set the vehicle through the menu in the multimedia host.

Internet Of Vehicles*

You can remotely control the vehicle, view the vehicle status, and perform voice interaction through the intelligent network system of the vehicle.

You need to download and install “MG iSMART” application from Google play Store for Android operating system or from App Store for IOS operating system, then register and connect it to the vehicle .

Vehicle Maintenance

Accessories and Vehicle Retrofitting

We recommend the use of original spare parts and parts specially matched with this vehicle approved by our company. We do not recommend the use of other products, even if they meet the specified requirements or are otherwise approved.

Without the approval of MG, do not retrofit the electrical system.

Precaution

Do not retrofit the vehicle. Retrofitting may affect the vehicle performance, durability and safety. Any problems caused by retrofitting are not within the scope of warranty. The Company will not bear corresponding responsibilities for the safety problems caused by retrofitting.

Long-term Parking

Several months of storage of the vehicle:

- Clean and wax the vehicle.
- Check the wax coating of front compartment and the underbody.
- Clean and protect the rubber seal.
- Drain the windshield washing fluid reservoir.
- Adjust the tire pressure according to the specified value under full load.
- Charge the traction battery to about 60%.
- Close all doors and lock the vehicle.
- Check that the handbrake is pulled up completely and the vehicle will not move.
- Disconnect the clip from the vehicle battery negative terminal. Pay attention to that all systems are out of service at this time, e.g., theft alarm system.

When The Vehicle is to be Put Back Into Service

- Connect the clip to the vehicle battery negative terminal. Enable the electronic device of power window.
- Check the tire pressure.
- Fill up the windshield washing fluid reservoir.
- Check the coolant level.

Driver Checklist

Check the interior, exterior and front compartment regularly to keep the vehicle safe and reliable.

Exterior

Tires

- Inflate correctly. See “Wheels and Tires” in this chapter.
- There is no crack on tire wall or tire tread.
- There are no foreign matters in tread pattern.

Lights

- Include all driving lamps, headlamps, tail lamps, turn signal lamps, brake lamps and fog lamps.

Windscreen Wipers

- Check the state of wiper arms and blades.

Interior

Steering

- Check whether the steering wheel is too loose (free stroke).

Parking Brake

- Ensure the stroke of parking brake lever is appropriate.

Instrument Panel

- Check whether all instruments, control buttons and warning lamps are functioning normally.

Rearview Mirror

- Ensure the reflecting surface of rearview mirror is in good state and clean.
- Check whether all rearview mirrors can be readjusted.

Control

- Check the brake pedal and clutch pedal for appropriate stroke.



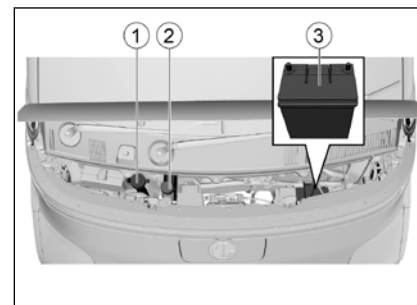

Front Compartment



1. Windshield washing fluid reservoir
2. Brake fluid reservoir
3. 12V battery

12 V Battery

Warning notice on battery:

-  Wear glasses!
-  Wear protective gloves and glasses since battery acid is highly corrosive!
-  Open flames, electric sparks, strong light and smoking are prohibited!
-  Explosive mixed gas may be produced during battery charging!
-  Children should be kept away from acid and battery!

Your vehicle is equipped with a MG authorized genuine battery, located in the front compartment.

According to the current load condition and battery status, the system may limit the power of some electrical appliances. Please ensure the vehicle is placed in READY mode as soon as possible to charge the battery.

Best Battery Service

DO NOT leave electric components switched on when not in READY mode, this may cause the battery to become flat, resulting in the failure of the ability to set vehicle into READY mode and the reduction of battery life.

- Keep the battery top clean and dry.
- Keep the terminals and connections clean, tight, and coated with petroleum jelly or terminal grease.
- Rinse any spilled electrolyte from the battery immediately with a solution of water and baking soda.
- Keep the battery securely mounted.
- Tighten loose terminals and hold down clamp nuts only enough to keep the battery firmly in place.
- Tightening excessively may damage the battery terminals.

Note

To avoid battery discharge, please turn off the ignition switch when leaving the vehicle.

 **Risk of injury, corrosion, accident and fire exists when operating on vehicle battery and electrical appliance!**

Wear protective glasses. Prevent acidic or lead particles from falling into eyes, on skin or clothes.

 **Wear protective gloves and glasses since battery acid is highly corrosive! The battery can not be turned over because the acid may flow out of the air vent. If the acid splashes into eyes, wash with clean water for a few minutes, then go to see a doctor immediately. If the acid splashes on skin or clothes, immediately neutralize it with rich soap solution and rinse with plenty of water. If you mistakenly drink acid, go to see a doctor immediately.**

 **Open flames, electric sparks, strong light and smoking are prohibited! Avoid sparking when handling cables and electrical equipment and removing electrostatic loads. Battery electrode must not be short-circuited because sparks with high energy pose a risk of injury.**

 **A battery generates hydrogen gas which is flammable and explosive. Keep any flame or spark away from the vent holes.**

Battery charging may produce explosive mixed gas, you must ensure that the battery air vent is open to successfully discharge the gas. The battery should be located in a well ventilated space during charging.

Children should be kept away from acid and battery.

Turn off the engine, ignition switch and all the electrical appliances before working on electrical appliances. Remove the battery negative cable. Turn off the lamp in bulb replacement.

Please pay attention to the polarity of power supply. check if the polarity of power supply matches before energizing.

Each energizing period should not be less than 5 seconds, to avoid frequent or fast on and off operation.



Turn off all the electrical appliances before energizing the battery again. First connect the positive cable, then the negative one. Do not connect the wrong

cable - Risk of fire!

Unauthorized removal and installation of battery are prohibited, because in some cases, this operation will lead to serious damage to the battery and fuse box. Please contact Service Dealer.



Do not disconnect the battery when the ignition switch is on or the engine is running, otherwise it may damage the electrical appliances (electrical components).

To prevent the battery case from being exposed to ultraviolet light, do not expose the battery to sunlight.

Never attempt to dismantle a battery, they are sealed units.

While removing the battery, always disconnect the negative terminal first. And while installing the battery, ensure the negative terminal is connected last.

If the battery has been disconnected or a new battery has been installed, the preset radio (if

equipped) stations will get reset, once the battery is reconnected.

Notes

The replacement battery must meet the specification of the MG recommended battery.

Car Parking Period

If the vehicle is to be parked for an extended period of time, the static current electrical appliance (like clock, security devices) will drain the battery, and the battery has to be recharged. To avoid such case, charge the battery or disconnect the battery negative cable during the vehicle parking.

Note: Please pay attention to the warnings & instructions for battery before working on it.

It is recommended to ensure the vehicle is placed in READY mode for half an hour every week to help extend the service life of the battery. If the vehicle is stored for more than 1 month, remove the negative terminal from the battery. Make sure that the vehicle power system has been turned off before connecting or disconnecting the negative terminal.

Caution

Always turn off the ignition switch when parking, otherwise, it will greatly reduce the parking time.

Battery Charge with Ground Equipment

Don't charge the frozen battery for the risk of explosion. Even if the battery has been unfrozen, battery acid may still overflow, resulting in corrosion damage. The frozen battery must be replaced.

Turn off the ignition switch and all electrical appliances before charging.

If the vehicle has been stored for an extended period of time, and can not be started due to battery undercharge (general terminal voltage $\leq 12V$), the battery must be removed from the vehicle and charged with ground equipment (operating in accordance with the charging device manufacturer's instructions).

When charging with a low current (such as a small charging device), generally it is not required to remove the battery connecting cables. But you must pay attention to the instructions given by the charging equipment manufacturer.

Before the quick charge, that is, before the high current charge, you must remove two connecting cables.

Note: Please pay attention to the warnings & instructions for battery before working on it. When charging, the power supply of charging device can be switched on only after the charging device electrode chuck clipped to the battery electrode as specified. After charging, first turn off the charging device, unplug the power cord, and then remove the electrode chuck of charging device from the battery.

Caution

- Keep children away from the battery, battery acid and charging devices.
- The battery can only be charged in an ventilated space. Smoking, open flame and electrical sparks are prohibited, because explosive mixed gas will be produced during battery charging!
- To protect your eyes and face, please stay away from the battery.
- If the acid splashes into eyes or on skins, rinse with clean water for a few minutes and go to see a doctor immediately.
- Battery fast charging is dangerous and should be performed by Service Dealer, because it requires specialized charging equipment and knowledge.
- Replace the frozen or unfrozen battery. Cracking may occur on the battery case because of freezing. Battery acid may leak and damage the vehicle.

Important

Checking the Electrolyte Level

Check the electrolyte level and specific gravity at specific PMS intervals. Check proper electrolyte levels for all the cells. If the level is below the lower marker, add distilled water until the level reaches the upper marker.

Adding distilled water:

- Remove the vent plugs
- Add distilled water to all the cells that require the fluid and secure the plugs properly

Battery Removal

Turn off the ignition switch and all electrical appliance before removing the battery.

To remove the battery, you should first remove the negative cable, next the positive cable, and then remove bolts on the battery retaining bracket , finally remove the battery.

Battery Replacement

Please go to an MG Authorised Repairer to remove and refit the battery.

Please note that the ignition switch and the electrical appliance have been turned off when installing the battery.

Note

Only fit MG recommended battery while replacement to maintain the correct vehicle functionality.

Battery needs to dimensionally OK, to avoid terminals fouling with Battery Tray.



The used battery should not be discarded at will, for it is harmful to the environment. It must be recycled by approved agencies. Please consult an MG Authorised Service center for more details.

Battery Installation

Turn off the ignition switch and all electrical appliance before removing the battery.

Place the battery in the mounting position and secure it with battery bracket.

Secure the positive cable then the negative one, then energize the battery.

Caution

To avoid battery discharge, please turn off the ignition switch when leaving the vehicle.

Note

The MG motor shall not be liable/responsible for any damages/injuries, including consequential damages/injuries, resulting due to fitment of non OEM approved batteries.

Brake Fluid

Add Brake Fluid



1. Thoroughly wipe off the dirt around the reservoir filler cap.
2. Open the filler cap.
3. Fill the brake fluid recommended by MG to the MAX mark of the fluid reservoir. Be careful not to spill the fluid on the paint surface. In case of spilling on the paint surface, wash the area with cold water immediately.
4. Re-install the reservoir filler cap.

Notes

Before opening the oil filler cap, clean the area around the brake fluid reservoir filler cap.

Contamination of the brake fluid system will affect the system performance, resulting in costly repairs.

Windshield Washing Fluid

Before driving, be sure that the washing fluid reservoir contains sufficient specified washing fluid.

In cold weather, the windshield washing fluid reservoir cannot be overfilled. Washing fluid will swell under low temperature due to freezing. An overfull container has no enough space for expansion, thus resulting in damages.

Fuse

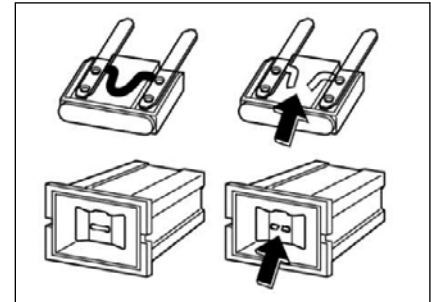

Fuse Replacement:

1. Open the fuse box cover.
2. Identify damaged fuses by finding out blown fuses.
3. Remove the Blown fuses.
4. Figure out the cause of fuse blowout and remove the malfunction.
5. Install new fuses with rated current meeting the requirements

Fuse Box

Front Compartment Fuse Box

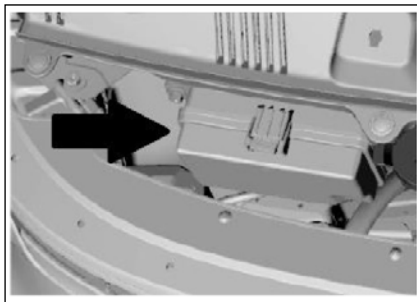

The fuse box is located at the right of the front compartment.

Precaution

Do not use a conductive tool to remove the blown fuse. The fuse extractor must be used. The use of metal and other electric conductors may cause a short circuit, damage the electrical system or cause a fire, resulting in serious personal injury.

Precaution

The use of fuse substitutes or the fuse with an incorrect type and rated value may damage the electrical system or cause a fire. Be sure to use a fuse whose type and rated current meet the requirements. Otherwise, it may cause personal injury and damage the vehicle and other properties.

Lamp Fogging

When the temperature is low or the air is humid, you may see mist in the lamps. After turning on the lamps, the mist will disappear in a short time. This is weatherrelated and does not require maintenance.

If the mist still exists after the lamp is turned on, please contact the service center for maintenance.

Wheels and Tires

Original tires guarantee optimum matching of riding comfort, tread life and performance.

Precaution

Be sure to use wheels and tires of specified specifications. The use of wheels and/or tires of other specifications may result in abnormal operation of ABS and other relevant components and even cause collision accidents. Please consult the After-Sales Service Center before replacing original tires or wheels. Otherwise, it may cause personal injury and damage the vehicle or other properties.

Maintenance

Tire Pressure	64
Tire & Wheel Maintenance.....	64
Tire Rotation	65
Jump Start (Dead battery).....	66
Towing.....	66
Cleaning & Vehicle Care	68

Tire Pressure

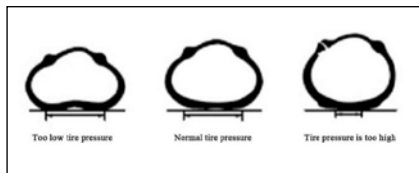

The tire pressure shall meet provisions of this Manual so as to ensure optimum matching of driving comfort, safety and driveability.

Please refer to “Technical Data” for the correct tire pressure.

When the vehicle is in cool state, check the tire pressure with an accurate tire pressure gauge. After check of tire pressure, tighten the valve core cap.

Check the tire pressure each time when refueling or at least every month. Incorrect tire pressure may:

- Increase tire wear and vehicle deviation.
- Affect the vehicle maneuverability and safety.
- Affect the riding comfort.
- Oil leakage.

Excessively low tire pressure will cause overheat of the tire, leading to internal damage and layered tread and even tire burst when driving at a high speed. Even if the tire pressure was restored later, driving under too low pressure may have damaged the tire.

Tire and Wheel Maintenance

Running over sharp objects may damage tires and wheels.

If you have to run over these objects, please slow down.

Do not touch the curb when parking.

Regular Tire Check

Regular Inspection:

- Appearance damage. These include foreign material, punctures, cuts, cracks, and sidewall projections.
- It is also required to inspect the wheel for damage.

Tire defects including the above defects may lead to vehicle out of control, causing personal injury. In case of damage or abnormal wear of tire or wheel, please consult the After-Sales Service Center for help.

The vehicle is equipped with radial tires. MG suggests replacing with radial tires of the same size, pattern, tread wear, temperature and rated speed.

Tyre Rotation

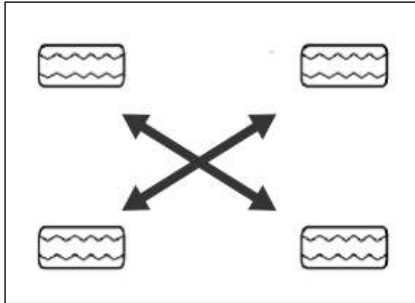

The front tyres and the rear tyres have different functions and therefore have different levels of wear. The front tyres wear faster than the rear tyres. In order to prolong the tyre life and avoid uneven treadwear:

1. Conduct tyre rotation as per maintenance regulations in the Manual.
2. Keep a proper tyre pressure.
3. Check nuts/bolts for tightening.

Precaution

Please use the recommended wheels and wheel nuts/bolts.

Otherwise, it may lead to the vehicle out of control and cause collision accidents, resulting in personal injury and damage of vehicle or other properties.

Tread Wear Indicator

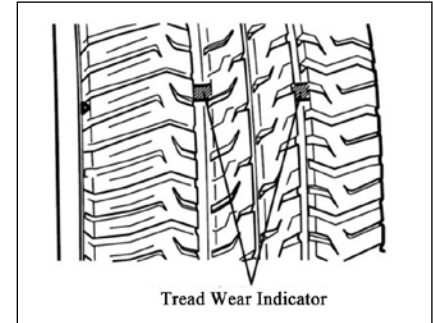

Check the tyre tread depth as per the tread wear indicator regularly. The mark on the tyre wall indicates the position of the tread wear indicator.

The tyre must be replaced when the tread wear indicator appears. When the tread depth is equal to or less than 1.6 mm due to wear, the tread wear indicator will appear between the tread grooves.

Jump Start (Dead Battery)

If the vehicle cannot be started without power, you can borrow the battery of another vehicle to provide power for your vehicle through jump start.

Preparation before Jump Start

1. Apply the parking brake.
2. Engage "N".
3. Turn off all electrical accessories.

Notes

Turn off the audio equipment before jump start of the vehicle. Otherwise, the audio system may be damaged.

When the vehicle is running at a low speed for a long time (such as traffic jam), turn off all unnecessary electrical systems.

Jumper Cable Connection

In case of jump start of the vehicle, connect the jumper cable in the following order:

1. Clip one end of the first jumper cable to the positive terminal of the powered battery. (There is a "+" mark on the battery housing or the terminal)
2. Clip the other end of the jumper cable to the positive terminal of the dead battery. (There is a "+" mark on the terminal.)
3. Clip one end of the second jumper cable to the negative terminal of the powered battery. (There is a "-" mark on the battery housing or the terminal)
4. Connect the other end of the cable to the body ground of the vehicle that has no electricity.
5. After connection, follow the starting steps to make the vehicle enter the READY state and complete the starting.
6. To remove the jumper cable carefully in reverse order, remove the negative cable first and then the positive cable.

Towing

If towing is necessary, please contact the After-Sales Service Center or a professional towing service company.

Tow your vehicle with a wheel lifter.

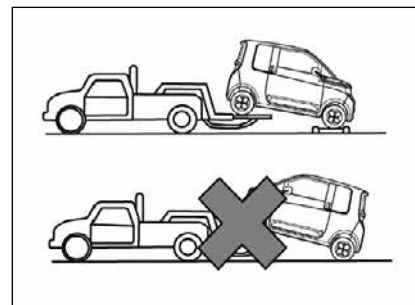

1. Turn on the hazard warning flasher.
2. Turn the ignition switch to ACC position.
3. Engage "N".
4. Release the parking brake.
5. Rear wheels must be off the ground when towing.

Tow your vehicle with a flatbed trailer.

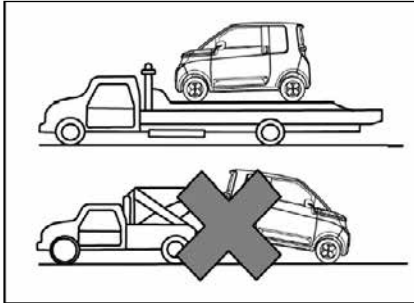

When towing the vehicle with a platform trailer, turn off the ignition switch and check that the vehicle is firmly attached to the trailer.

Emergency Towing

If the tractor is not available in case of an emergency, it can secure the rope on the front towing hook under the vehicle for temporary vehicle towing.

When the vehicle is towed via the front towing hook, only tow rope can be used. Do not use a rigid tow bar.

Your vehicle can only be towed by other vehicles but not used to tow other vehicles.

Front Towing Hook

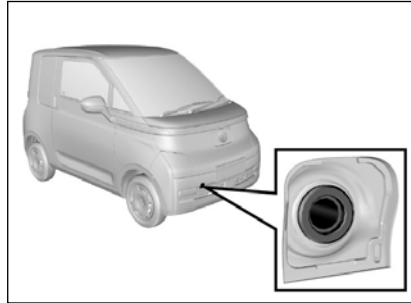

There is a hole cover on the right side of the front bumper of the vehicle. Open it and the fixing hole for hook installation can be seen. Take out the towing hook from the tool bag and install it into the fixing hole. Rotate the towing hook clockwise to tighten it completely and insert a sleeve wrench into the hook hole to assist tightening. Be sure that the towing hook is installed firmly before towing the vehicle. When towing the vehicle, the driver must control steering and braking in the vehicle. After completion of traction, remove the towing hook and close the hole cover, and then put the towing hook back.

Precaution

The towing speed shall not exceed 30 km/h, and the towing distance shall not exceed 40 km. When long-distance towing is required, it is suggested to contact the After-sales Service Center or a professional towing service company for help.

Cleaning & vehicle Care

Cleaning Agent

The manufacturer's suggestions must be observed when using cleaning agent or other chemical products inside or outside the vehicle.

Do not use dangerous cleaning agent when cleaning the interior and exterior of the vehicle. For example:

- Acetone
- Paint diluent
- Porcelain glaze reducing agent
- Nail polish remover

When cleaning the interior and exterior of the vehicle, the following cleaning agents are prohibited unless special instructions for cleaning stains are included in the fabric cleaning tips:

- Laundry soap
- Bleaching powder
- Reducing agent

Warning

Some cleaning agents are toxic,corrosive or flammable. Improper use is very dangerous and may easily cause personal injury or vehicle damage.

Do not use the following materials for cleaning:

- Carbon tetrachloride
- Gasolinet
- Benzene
- Naphtha

When using any cleaning agent or other chemical products inside the vehicle, please open the doors for proper ventilation. To avoid permanent color change of light-colored interior trims, do not allow the easy- todiscolor fabrics to come into contact with the seat liner unless both materials are completely dry. Fabrics with easy-to-discolor materials are:

- Casual clothes
- Dyed denim
- Leather
- Kidskin

Warning

Avoid prolonged exposure to cleaning agents and other chemical vapors. Such chemical vapor is extremely dangerous and harmful to the health, especially in limited space without ventilation.

Vehicle Interior Maintenance and Cleaning

Clean the interior and exterior of the vehicle with proper cleaning methods and materials.

Use a vacuum cleaner or a banister brush to remove dust and scum that accumulate on the fabric inside the vehicle frequently.. Wipe the vinyl plastics and leather trims regularly with a clean wet cloth. Remove dust, spots or stains on trims with a suitable cleaning agent.

Warning

Clean the interior trims of the vehicle with proper cleaning methods and materials.

Otherwise, it will produce water spots, watermarks and permanent spots, especially during the first washing. These substances will permanently damage the vehicle.

Seat Belt Maintenance

Keep the seat belts clean and dry. Prevent seat belts from being contaminated by polishing agents, oils and chemical products, especially battery fluid, bleaching powder or dyestuff. These contaminants will reduce the strength of the seat belt material. Check all seat belt parts regularly. Replace any damaged seat belt or part immediately.

The seat belt or related parts that are stretched during the accident must be replaced, even if the damage is not obvious or is not visible. The seat belt for replacement must be new.

MG Motor suggests replacing the whole seat belt assembly after collision. It is not necessary to replace the seat belt after it is checked to be undamaged and normal by the MG Authorised Service Center for solution.

Notes

The seat belt must be kept in good working condition to maintain its normal function.

Wiper Blades

Wash in warm soapy water. DO NOT use spirit or solvent based cleaners.

Weather Strips and Rubber Seals

Any weather strips or rubber aperture seals should be treated with suitable materials (silica gel) if they are cleaned using strong detergents, this should avoid any sticking and maintain the service life of the seal.

Glass Surface

Make sure that the window glass is clean, which helps reduce glare and improve vision.

Front Windshield Outside Cleaning

Waxes or other materials on the front windshield and blade may cause the blade to shake when working. Moreover, such foreign matters are not conducive to keeping the front windshield clean. Clean the outside of the front windshield regularly with a non-abrasive cleaning agent.

Water does not form water droplets on the clean front windshield.

Notes

Decals will affect the rear windshield defroster. Do not paste decals on the inner side of the rear windshield. Otherwise, it will affect the driver's vision.

Notes

The non-abrasive cleaning agent will scratch the glass and damage the rear windshield defroster grid lines.

Do not use abrasive cleaning agent on vehicle glass. Otherwise, it will affect the driver's vision.

Vehicle Exterior Maintenance and Cleaning

⚠ Observe all safety precautions on cleaning products; Do Not drink fluids and keep them away from the eyes.

Exterior

Washing Your Car

⚠ Ensure the vehicle power system is OFF when washing your car.

⚠ Some high pressure cleaning systems will penetrate door, window and sunroof seals, and damage lock mechanisms. DO NOT aim water jets directly at components that might be easily damaged.

⚠ Do not clean the front compartment, charging point, high voltage battery & electrical connections with high pressure water since it may damage the electrical system of the vehicle.

In order to preserve the paint finish on your car, please observe the following care points:

- DO NOT use hot water to wash the car.

- DO NOT use detergents or washing up liquid.
- DO NOT use high pressure more than 2.5 bar for washing the car body.
- In hot weather, DO NOT wash the car in direct sunlight.
- When using a hose, DO NOT aim the water directly at window, door or sunroof seals, or through wheel apertures onto the brake components.

If the car is particularly dirty, use a hose to flush grime and grit from the bodywork, prior to washing. Then, wash the car using cold or lukewarm water containing a good quality wash and wax shampoo. Always use plenty of water to ensure that grit is flushed from the surface and not ground into the paintwork. After washing, rinse the bodywork with clean water and dry off with a chamois leather.

Cleaning the Underside

Note: DO NOT clean the battery underneath – damage to the car’s electronic systems may occur.

Flush away accumulations of mud and thoroughly clean those areas where debris can easily collect (wheel arches and panel

seams, for example) using pressure hose with pressure not more than 2.5bar. Make sure you do not wash HV battery , charging points & electrical connections– damage to the car’s electronic systems may occur.

IMPORTANT

- Avoid cleaning the vehicle in direct sunlight.
- When cleaning the vehicle in winter avoid spraying water directly onto door locks and panel gaps due to risk of icing.
- Do not use rough sponges or cloth to clean the car, this will damage the paintwork finish.
- When cleaning the headlamps do not use a dry cloth or sponge, use only warm soapy water.

Cleaning with a High Pressure Cleaner

Note: *DO NOT high pressure of more than 2.5 bar for car cleaning.*

When using high pressure washers, always ensure there is adequate distance between the spray nozzle and any soft materials, decals or rubber seals.

IMPORTANT

- Please pay attention to the operating instructions of high-pressure cleaner.
- High pressure cleaners should not be closely directed at soft parts of the vehicle.

Polishing and Waxing

Regular polishing can remove residues from the surface of the vehicle. After polishing, use high-quality car wax for protection.

Notes

It is forbidden to clean or polish aluminum trims with automotive or chrome polishing agent, steam or alkaline soap liquids. These substances are abrasive and may damage trims and wheels.

Exterior Bright Metal Parts Protection

Clean the bright metal trims regularly. They are usually washed with water. When waxing the vehicle, please also wax these bright metal parts.

Aluminum Wheels and Wheel Trim Cover Cleaning

To maintain the original appearance of the wheel and wheel trim cover (if any), do not allow them to collect dust or brake dust. Clean the wheel / wheel trim cover regularly. Do not use abrasive cleaning agent or brush that may damage the finish paint.

Notes

Do not use abrasive cleaning agent or brush to clean aluminum wheels or wheel trim covers.

Warning

Keep yourself, test leads, clothing and other objects clear of electrical connections and hot or moving vehicle parts.

Do not wear watches, rings, or loose clothing when working in an Front compartment.

Make sure no loose material (Cloth or other inflammable material etc) is left (but not limited to) inside front compartment/ Fender after washing.

Corrosion Prevention

MG Motor vehicles are designed to have anti-corrosion capabilities. The use of special materials and protective paint on most vehicle parts helps maintain satisfactory appearance, strength and reliability.

Although the surfaces of certain parts inside the front compartment or of the underbody may rust, the reliability or performance of these parts will not be affected.

Metal Plate Damage

If the body needs to be repaired or replaced, ensure that the repair shop uses proper anti-corrosion materials to restore the anti-corrosion protection performance.

Foreign Matter Deposition

The following substances may damage the paint surface:

- Calcium chloride and other salts
- Ice melting agent
- Road surface oil and asphalt
- Sap
- Bird droppings
- Industrial dust

Remove harmful substances on the vehicle in time. If residues cannot be removed with soap liquid, a special cleaning agent can be used.

Finish Paint Damage

Repair the gravel scratches, cracks or deep scratches on the finish paint as soon as possible. Exposed metal is prone to corrosion. Quick-drying products can be used to repair tiny cracks and scratches. Body and paint repair shops can complete large-scale repairs.

Notes

Only safe cleaning agents that are harmless to the paint surface can be used.
Other cleaning agents may permanently damage the paint.

Technical Data

Main Parameters and Performance

Indices of Drive Motor76

Main Performance Parameters of
Traction Battery System(6.6kW)77

Main Vehicle Mass Parameters.....78

Main Liquid Parameters78

Main Vehicle Dimension Parameters.....79

Wheel Alignment (Unladen) Parameters79

Tire Inflation Pressure (Cold State).....79

List of Accompanying Parts80

Technical Data

Main Parameters and Performance Indices of Drive Motor

Items	Unit	Index
		Comet EV
Type	--	Permanent magnet synchronous motor
Peak power	kW	31
Peak torque	N.m	110
Peak speed	r/min	7600
Cooling mode	--	Natural air cooling
Controller model	--	Control mode of vector
Cooling mode of controller	--	Natural air cooling
Maximum speed	km/h	100

Main Performance Parameters of Traction Battery System (6.6 kw)

Items	Unit	Index
		Comet EV
Category	--	Lithium iron phosphate battery
Type	--	Energy type
Model of battery cell	--	IFP54173145A-150Ah / CB54173145EA
Nominal voltage of battery cell	V	3.2
Total mass	kg	147 / 154
Total energy	kWh	17.3 / 17.4
Total nominal voltage	V	115 / 116
Total nominal capacity	Ah	150
Rated output current	A	170

Technical Data

Main Vehicle Mass Parameters

Items	Unit	Index
		Comet EV
Seating capacity	Person	4
Curb weight	kg	806(LV0), 817(LV1,LV2), (830) LV1 FC, 832(LV2+), (845)LV2+FC
Gross vehicle weight (GVW)	kg	1130 / 1150

Main Liquid Parameters

Name	Brand	Index
		Comet EV
Reducer Fluid	GL-5 75W-90	1.0±0.05L
Brake fluid	DOT4	0.55±0.05L
A/C refrigerant	HFC-134a	400g±20g / 450g±20g
Windshield washing fluid	Methanol-water solvent	1.20±0.15 L

Main Vehicle Dimension Parameters

Items	Unit	Parameter Value
Total length	mm	2974
Total width	mm	1505
Total height (no load)	mm	1650
Axle base	mm	2010

Wheel Alignment (Unladen) Parameters

	Item	Parameter
Front	Toe in (Total)	0°12 ± 5'
	Camber Angle	36' ± 45'
	Caster	3°30 ± 45'
	Kingpin Inclination angle	8°39 ± 1°
Rear	NA	

Tire Inflation Pressure (Cold State)

Tire Model	Items	Tire Inflation Pressure (unit: kPa)
		Laden
145/70R12	Front wheel	250(36PSI)
	Rear wheel	250(36PSI)

List of Accompanying Parts

S/N	Name	Quantity	Description
1	Towing hook	1	
2	AC charger	1	
3	Triangle warning sign	1	
4	First-aid kit	1	
5	Tire repair kit	1	

DELIVERY OF YOUR VEHICLE

Dealer Name..... **Dealer Address**.....

FIRST NAME SURNAME

MODEL

VEHICLE DELIVERED ON BY

PRESENTATION AND EXPLANATION

1 FRONT OF THE VEHICLE

Eg. Servicing details, Checking the levels

2 FRONT PASSENGER SIDE

Eg. Disconnecting the passenger airbag (to fit a child seat to the front seat)

3 REAR OF THE VEHICLE

Eg. Location of the spare wheel, tool kit

4 REAR SEATS

Eg. Child safety (Isofix fixing point)
Modularity of the seats

» Was your vehicle presented to you as stated above?

YES NO

» Did your vehicle match your vehicle order?

YES NO

5 DRIVING POSITION

Eg. Adjusting the driving position. Use of the instrument panel and controls. Specific points relating to your vehicle.

Eg: Programming the radio, bluetooth, automatic illumination of the headlights, etc.

6 DEALER SERVICE DEPARTMENT

7 WARRANTY AND MAINTENANCE CONDITIONS

Eg. Warranty and maintenance documents (Service sheet or warranty & maintenance booklets), maintenance stamps

8 ISSUED WITH

- Two set of keys
- Tool kit
- Spare tyre
- Vehicle invoice
- Insurance cover note
- Registration document
- Vehicle manual

Delivery of Your Vehicle

Comments:

.....

.....

.....

Please note that MG Motor India will not be responsible for any issues pertaining to Non Genuine Accessories fitted either by dealership or aftermarket.

Should you require any further details regarding the vehicle handover or if you have any questions relating to your vehicle, please do not hesitate to contact your Sales or Delivery Advisor.

ENJOY DRIVING YOUR NEW MG!

CUSTOMER SIGNATURE

DELIVERY ADVISOR SIGNATURE

1st EXEMPLARY : CUSTOMER

2nd EXEMPLARY : DELIVERY ADVISOR

DELIVERY OF YOUR VEHICLE

Dealer Name..... **Dealer Address**.....

FIRST NAME SURNAME

MODEL

VEHICLE DELIVERED ON BY

PRESENTATION AND EXPLANATION

1 FRONT OF THE VEHICLE

Eg. Servicing details, Checking the levels

2 FRONT PASSENGER SIDE

Eg. Disconnecting the passenger airbag (to fit a child seat to the front seat)

3 REAR OF THE VEHICLE

Eg. Location of the spare wheel, tool kit

4 REAR SEATS

Eg. Child safety (Isofix fixing point)
Modularity of the seats

» Was your vehicle presented to you as stated above?

YES NO

» Did your vehicle match your vehicle order?

YES NO

5 DRIVING POSITION

Eg. Adjusting the driving position. Use of the instrument panel and controls. Specific points relating to your vehicle.

Eg: Programming the radio, bluetooth, automatic illumination of the headlights, etc.

6 DEALER SERVICE DEPARTMENT

7 WARRANTY AND MAINTENANCE CONDITIONS

Eg. Warranty and maintenance documents (Service sheet or warranty & maintenance booklets), maintenance stamps

8 ISSUED WITH

- Two set of keys
- Tool kit
- Spare tyre
- Vehicle invoice
- Insurance cover note
- Registration document
- Vehicle manual

Delivery of Your Vehicle

Comments:

.....

.....

.....

Please note that MG Motor India will not be responsible for any issues pertaining to Non Genuine Accessories fitted either by dealership or aftermarket.

Should you require any further details regarding the vehicle handover or if you have any questions relating to your vehicle, please do not hesitate to contact your Sales or Delivery Advisor.

ENJOY DRIVING YOUR NEW MG!

CUSTOMER SIGNATURE

DELIVERY ADVISOR SIGNATURE

1st EXEMPLARY : CUSTOMER

2nd EXEMPLARY : DELIVERY ADVISOR

MG Motor New Vehicle Warranty

Terms & Conditions

1. General:

Your MG MOTOR vehicle is manufactured to meet the regulations and environmental requirements for Indian conditions. In case you relocate it to any other country than INDIA, it may be very difficult to make modifications to comply with the regulations and environmental requirements of that country and it may be difficult to perform repair service in that country.

Please note that a vehicle relocated to any other country than India shall not be covered by the warranty.

2. New Vehicle Warranty

2.1 Duration of New Vehicle Warranty:

New vehicle delivered by an authorized MG MOTOR DEALER, are warranted against any material, assembly or manufacturing defects by the Manufacturer. The New Vehicle shall be covered under a Warranty by MG MOTOR for a period of

- **Personal Registration -**

3 years or 1,00,000 kms (whichever is earlier)

- **Commercial Registration -**

3 years or 1,00,000 kms (whichever is earlier)
MG Motor new vehicle warranty starts from the Delivery Date shown in the Owner's Manual issued to the Customer/ First Owner of the vehicle upon delivery of the vehicle purchased. (Transfer of ownership of the vehicle does not alter the warranty period of a vehicle.)

- **Battery Pack**

The warranty coverage for Battery pack is valid for 8 years or 1,20,000 kms whichever is earlier starting from the Delivery Date shown in the Owner's Manual issued to the Customer and shall be provided by the respective Battery Manufacturer as per their warranty terms and conditions.

2.2 Geographical coverage:

2.2.1 This warranty covers any new vehicle sold within geographical boundaries of INDIA.

If the vehicle is to be driven and, more importantly, registered outside the geographical area defined above, such vehicle will not be covered under the current warranty as stated herein.

2.3 The period of warranty on the vehicle shall not be deemed to be extended by repairs or replacements of any parts.

2.4 In the event the Original Purchaser of the vehicle transfers the vehicle during the period of warranty, it shall be obligation of the subsequent purchaser to notify and inform MG Motor or its authorized dealer of such transfer.

2.5 If the vehicle identification number (VIN) of an insured vehicle is declared as total loss by the insurer, any Warranty, Extended Warranty, free services, i-call, e-call and i-smart app (facilities if applicable) provided in respect of such vehicle shall become null and void with effect from the date VIN of such vehicle is declared as total loss by the insurer.

Field of Application:

2.5 The Customer is covered for:

2.5.1 Free repair (parts, consumables and labour) of any material or assembly defect duly found in the vehicle, at their own request, as well as any repairs on damage caused by this defect to other vehicle parts.

2.5.2 24/7 assistance services as defined in the "MG MOTOR Road Side Assistance" section.

2.5.3 It is the authorized MG MOTOR EV Dealer's discretion to decide whether it is appropriate to repair or

replace the defective part with new part(s), whilst keeping the Customer informed.

- 2.5.4** During a capacity check at an Authorised MG EV Dealer if it is determined that battery pack has suffered a capacity drop below acceptable degradation according to the use and ageing of the vehicle, the module below this acceptable degradation will be deemed excessive loss. Where possible the excessive loss portion will be repaired, if unreparable the battery pack will be replaced with either a new / remanufactured / reconditioned battery as per MG MOTOR Dealer's discretion.

2.6 Parts not covered under warranty conditions contained herein:

The following are the parts not covered by warranty conditions contained herein. Hence, it is requested to contact your nearest MG MOTOR Dealer for more details.

- 2.6.1 Battery:** The warranty coverage for 12V Battery is valid for 1 year starting from the Delivery Date shown in the Owner's Manual issued to the

Customer and shall be provided by the battery manufacturer as per their terms and conditions.

- 2.6.2 Tyre:** The warranty coverage for Tyre is valid for 1 year / 20,000 km whichever is earlier starting from the Delivery Date shown in the Owner's Manual issued to the Customer and shall be provided by the respective tyre manufacturer as per their warranty terms and conditions.

- 2.6.3 Infotainment / Audio system including T-Box:** The warranty coverage for Infotainment / Audio system is valid for 3 years from the Delivery Date shown in the Owner's Manual issued to the Customer and shall be provided by the respective manufacturer as per their terms and conditions.

- 2.6.4 Battery Pack:** The warranty coverage for Battery pack is valid for 8 years or 1,20,000 kms whichever is earlier starting from the Delivery Date shown in the Owner's Manual issued to the Customer and shall be provided by the respective Battery Manufacturer as per their warranty terms and conditions.

- 2.6.5 AC Chargers:** The warranty coverage for AC chargers is valid for 1 year starting from the Delivery Date. It shall be provided by the respective AC Charger manufacturer as per their warranty terms and conditions.

2.7 The MG MOTOR New Vehicle Warranty does not cover and MG MOTOR India Private Limited (MG MOTOR) and / or MG MOTOR authorized workshop shall not be responsible for the following:

- 2.7.1** Normal maintenance services other than 3 free services, including without limitation, cleaning and polishing, minor adjustments, engine tuning, oil / fluid changes, filters replenishment, fastener re-tightening, wheel balancing, wheel alignment and tyre rotation etc.
- 2.7.2** If the degree of degradation of the high-voltage battery is within the normal aging level according to the use of the vehicle. The criterion for normal aging of high-voltage battery conforms to our internal quality standards.

2.7.3 The indirect and remote consequences of any fault (loss of operation, duration of immobilization, etc.);

2.7.4 Vehicle components which have undergone conversion work, and/or specification and design changes and the consequences (deterioration, premature wear and tear, alterations, etc.) of the conversion work on other vehicle parts or components, or on its specifications;

2.7.5 The costs incurred by the Customer for routine maintenance;

2.7.6 Replacement of parts due to normal wear and tear resulting from use of the vehicle or from its mileage including but not limited to shocker absorbers, wiper blades, brake drum, brake disk, brake pads, brake shoe, lamp, plugs, belts, linings, bulbs, fuses, suspension parts, mountings, parts made of rubber, etc.

Other parts, not limited to steering wheel, gear knobs, gear bellows prone to normal wear & tear will have a limited coverage**

2.8 Damage or failure resulting due to the following causes:

2.8.1 Poor vehicle maintenance, in particular if the instructions for the treatment, the frequency of maintenance or care to be applied to the vehicle set out in the Owner's Manual have not been observed;

2.8.2 Use of improper battery charger, fluids or lubricants.

2.8.3 Due to lack of use / operation of vehicle over prolonged period[s];

2.8.4 Misuse, abuse, negligence, improper driving habits, theft etc. of the vehicle;

2.8.5 Damage from stress, like use of vehicles in races, rallies or as taxis. The warranty terms for the use of MG Motor vehicle shall be different / separate from the terms contained herein.

2.8.6 Use of parts other than MG MOTOR Genuine Parts.

2.8.7 Any device and / or accessories not Supplied / Fitted by MG MOTOR.

2.8.8 Modifications, alterations, tampering or improper repair.

2.8.9 Parts used in applications of which they were not designed or not approved by MG MOTOR.

Slight irregularities not recognized as affecting quality or function of the vehicle or parts, such as slight noise or vibrations, or items considered characteristic of the vehicle.

2.9 Damage caused by the following external causes:

2.9.1 Accidents, impacts, scratches, scoring, projection of gravel or solid bodies, hail, acts of vandalism;

2.9.2 Failure to observe the Manufacturer recommendations;

2.9.3 Deposits due to atmospheric pollution, plant-based deposits such as resin, animal-based deposits such as bird droppings, chemical deposits;

2.9.4 Transportation of the vehicle;

2.9.5 Fitting accessories not approved by the manufacturer;

2.9.6 Fitting accessories approved by the manufacturer, but installed without observing the recommendations defined by the manufacturer;

2.9.7 Damage due to airborne fallout, industrial fallout, acid rain, hail and wind storms, or other force majeure events like lightning, fire, floods, earthquakes, war, riots, attacks,

prolonged driving in submerged condition etc.

2.9.8 Damage caused due to hydro-static lock.

2.9.9 Paint scratches, dents or similar paint or body damage.

Incidental or consequential damages, including without limitation, loss of time, inconvenience, loss of use of vehicle or commercial loss.

How does the MG MOTOR New Vehicle Warranty work?

2.10 To be eligible for the MG MOTOR New Vehicle Warranty, the Customer must:

2.10.1 check that the Owner's Manual does contain the Delivery Date of the vehicle - their warranty entitlement is dependent on this;

2.10.2 contact any workshop of the MG MOTOR Authorized Workshop Network – only such Workshop have the authorization for operations of this sort;

2.10.3 show the duly completed Owner's Manual, as proof of entitlement to the warranty and that the maintenance operations

recommended by the Manufacturer have been carried out;

2.10.4 have the defect covered by the MG MOTOR New Vehicle Warranty confirmed as soon as possible, by a MG MOTOR authorized workshop in writing. If the vehicle is un-roadworthy, the Customer must contact the nearest MG MOTOR authorized workshop member or MG MOTOR Assistance.

2.11 The MG MOTOR New Vehicle Warranty does not apply, and MG MOTOR and MG MOTOR authorized dealer members are exempt from all liabilities, if:

2.11.1 The vehicle has been driven under conditions not in accordance with those stated in the Owner's Manual (example: vehicle overloaded or taking part in any type of sports competition, etc.);

The defect observed is due to the Customer having had the vehicle repaired or serviced in a workshop outside the MG MOTOR authorized network and not observing MG Motor's recommendations on the subject.

2.12 By way of consideration for the parts supplied by MG MOTOR under the MG MOTOR New Vehicle Warranty, parts replaced under this warranty, shall legally become the property of MG MOTOR.

2.13 All operations, parts and labour, carried out under the MG MOTOR New Vehicle Warranty are guaranteed until the new vehicle warranty expires.

2.14 Transferring ownership of the vehicle shall not alter the application conditions of the MG MOTOR New Vehicle Warranty.

3. The MG MOTOR Anti-corrosion Warranty:

3.1 Duration of the Anti-Corrosion Warranty: This warranty will apply from the delivery date given on the Owner's Manual for a period of:

- **Personal Registration** - 3 years or 1,00,000 km (whichever is earlier)
- **Commercial Registration** - 3 years or 1,00,000 kms (whichever is earlier).

3.2 Geographical Coverage: The geographical coverage of the Anti-Corrosion Warranty is identical to that for the MG MOTOR New Vehicle Warranty.

3.3 Anti-Corrosion Warranty field of application

3.3.1 In addition to the MG MOTOR New Vehicle Warranty, MG MOTOR guarantees the bodywork and sub frame of MG MOTOR vehicle Schedule I from perforation from the interior, due to steel panel corrosion caused by a manufacturing, material or protective product application defect.

3.3.2 This guarantee covers the repair or replacement of components with perforated steel panel work due to a manufacturing, material or protective product application defect, acknowledged by the Manufacturer.

3.3.3 It is authorized MG MOTOR workshop's discretion to decide whether it is appropriate to repair or replace these components, and to inform the Customer.

3.4 The MG MOTOR Anti-Corrosion Warranty does not cover:

3.4.1 any damage which is not covered by the MG MOTOR New Vehicle Warranty, as defined at the start of this booklet; Mechanical

components which are not an integral part of the bodywork or sub-frame (wheel rims, exhaust system, etc.).

3.4.2 In case, repairs (including denting or painting) have been carried out on the body of the MG Motor Vehicle in a workshop outside the MG MOTOR authorized network.

3.5 Anti-Corrosion Warranty conditions of application

3.5.1 To obtain the Anti-Corrosion Warranty, the Customer must contact any Workshop of the MG MOTOR Authorized Workshop Network - only such Workshop have authorization for operations of this sort.

3.5.2 The Customer shall show the duly completed (delivery date and validation of anti-corrosion test coupons) the Owner's Manual as proof of their warranty entitlement.

3.5.3 Application of the MG MOTOR Anti-Corrosion Warranty is subject to the anti-corrosion tests on the bodywork and sub-frame. Customer shall ensure that these tests are conducted at the mileage intervals

stated in the Owner's Manual, and at least once every two years. Scheduled maintenance services in the MG MOTOR authorized workshop network incorporate these tests.

3.5.4 If the Customer requests to have the anti-corrosion test conducted independently of the scheduled maintenance service, the same will be carried out at an extra cost to the Customer.

3.5.5 During these tests the Customer shall make sure that the professional carrying out the operation correctly completes the bodywork and sub frame test coupon, in order to validate the continuation of the Anti-Corrosion Warranty.

3.5.6 Repairs on any deterioration must be made as soon as possible.

3.5.7 The application of the MG MOTOR Anti-Corrosion Warranty is also subject to bodywork and sub-frame repairs being carried out in accordance with MG MOTOR recommendations.

3.5.8 The repair or replacement of components under the conditions described in the "field of application"

(Paragraph 7.3), shall taken into account the general condition of the vehicle with regard to its age, mileage and maintenance level.

3.5.9 Parts replaced under the Anti-Corrosion Warranty legally become the property of MG MOTOR.

3.5.10 Repairs and components fitted under the Anti-Corrosion Warranty are guaranteed until the end of the term of the original Anticorrosion Warranty.

3.5.11 Transferring ownership of the vehicle does not alter the application conditions of the Anti-Corrosion Warranty.

The MG MOTOR Paintwork Warranty:

3.6 Duration of the Paintwork Warranty: MG MOTOR guarantees the bodywork paintwork and painted parts paintwork (door mirrors, bumpers etc.) for 3 years or 1,00,00 km (for Personal Registration) 3 years or 1,00,000 kms (for Commercial Registration) (whichever is earlier) from the Delivery Date of the new vehicle.

3.7 Geographical Coverage: The geographical coverage of the Paintwork Warranty is

identical to that for the MG MOTOR New Vehicle Warranty.

3.8 Paintwork Warranty field of application:

3.8.1 This warranty covers the free repair or replacement of components with inherent paintwork defects (deterioration of lacquer or finishing varnish, due to any material, manufacturing or application defect) acknowledged by the Manufacturer, with the MG MOTOR authorized workshop carrying out the operation, keeping the Customer informed.

3.8.2 This repair shall take into account the general condition of the vehicle with regard to its age, mileage and maintenance level.

3.9 The MG MOTOR Paintwork Warranty does not cover:

3.9.1 any damage which is not covered by The MG MOTOR New Vehicle Warranty, as defined at the start of this booklet;

3.9.2 damage due to force majeure events: lightning, fire, floods, earthquakes, war, riots and attacks;

3.9.3 Mechanical components which are not an integral part of the bodywork or sub-frame (wheel rims, exhaust system, etc.).

Damage due to action of road elements (sand, gravel, dust or road debris) which results in stone chipping of paint or glass.

3.9.4 In case, the denting or painting job has been carried out on the MG Motor Vehicle in a workshop outside the MG MOTOR authorized network.

3.10 Paintwork Warranty conditions of application

3.10.1 To obtain the Paintwork Warranty, the Customer must contact any workshop of the MG MOTOR Authorized Workshop Network - only such Workshop have authorization for operations of this sort.

3.10.2 The Customer shall show the duly completed (delivery date) Owner's Manual as proof of their entitlement to the warranty.

3.10.3 By way of consideration for the parts supplied by MG MOTOR under the Paintwork Warranty, parts replaced

under this warranty legally become the property of MG MOTOR.

- 3.10.4** Repairs and components fitted under the Paintwork Warranty are guaranteed until the end of the term of the original Paintwork Warranty.
- 3.10.5** Transferring ownership of the vehicle does not alter the application conditions of the Paintwork Warranty.
4. This warranty is the entire Warranty given by MG MOTOR and no Authorized Dealer of MG Motor or its or his agent or employee is authorized to extend or enlarge this warranty and no Authorized Dealer of MG Motor or its or his agent or employee is authorized to make any oral warranty on MG MOTOR's behalf.
 5. MG MOTOR reserves the right to make any change in design or make any improvement in the design, structure, technology etc. of the vehicle at any time without any obligation to make the same change on the vehicles already sold.
 6. Warranty service shall be provided only by MG MOTOR's Authorized Dealers and Dealer Service Branch.
 7. MG MOTOR's decision is final and binding on the Owner of the vehicle in all warranty matters. MG MOTOR reserves the right for the final decision on all warranty matters.
 8. The terms and conditions as contained herein shall be construed in accordance to the laws as applicable in India and all disputes arising out of this Warranty will be subject to the jurisdiction of Courts in Gurugram only.

DISCLAIMER

MG Motor India has partnered with multiple application services & content providers for developing the complete/overall ecosystem experience of Internet Car features across all MGI models*. MG Motor India is committed to providing the best user experience and services and acts as an integrator for these application services & content providers. For any customer feedback, MG Motor India will coordinate with the respective content/service provider for resolution.

***Model variants applicable with Internet features.**

****For limited coverage details, please contact MG authorised service center**

MG Roadside Assistance 24x7

CALL 1800-100-6464

MG Roadside Assistance is designed to enhance your overall MG ownership experience, by providing you with 24hrs/7days emergency support related to the use of your MG Motor Vehicle. Peace of mind motoring- guaranteed.

While it is our sincere hope that your travels are always trouble-free, breakdowns and road traffic accidents do happen - our goal is to ensure that even if your MG is immobilized, whether at home or while travelling, any inconvenience to you and your family is minimized.

Should you ever require assistance, all you need to do is dial our 24-hour assistance hotline: 1800 100 6464 and or press the I-Call button on your car and MG Roadside Assistance will be there to help. Vehicles will be covered under this program for a period of 3 years from the Date of sale of the vehicle.

Getting Help - What to do when you need Assistance

In the event of a breakdown or accident, call MG Roadside Assistance on 1800 100 6464 (toll-free from anywhere in India), or press the I - Call button on your car. When placing the call, please have the following information handy for assisting the operator in analysing the issue:

- Description of the problem;
- Your location;
- Registered Contact / phone number, in case you are calling from a number other than your registered number, as registered with MG;
- License plate number/ Vehicle Identification number

if you opt for your own vehicle assistance / recovery management, the cost for the same shall be borne by you.

Covered Events

- o Human error
- o Key problems: locked keys, lost keys, or broken vehicle keys
- o Tyre problems: puncture, bolts or valve related issues, fix using tyre inflator kit provided along the car during purchase & should be available at the time of incident.
- o Road traffic accident where the vehicle is immobilized

Assistance will be provided no matter where you are (i.e. at home, on the roadside, on the highway, in a parking lot, etc.), as long as you are not already at an Authorized MG Comet EV Dealer.

Summary of Customer Benefits

Roadside Assistance at home or on the road If your vehicle is immobilized, whether at home or on the road, MG Roadside Assistance will attend to your vehicle. For conditions where we decide that the cause of the breakdown/immobilizations can be solved at the roadside, a technician will be sent to try and mobilize your vehicle at your location.

Vehicle Recovery

If your vehicle is unable to be mobilized following a mechanical or electrical breakdown, a recovery vehicle will be sent to recover your vehicle to the nearest Authorized MG Comet EV Dealer.

Taxi

If your vehicle is being towed to the nearest authorized MG Comet EV Dealer (for break down / accident cases), MG Roadside Assistance will also provide taxi assistance. Taxi will be given from breakdown spot and breakdown moment till the towed car reaches the workshop. (Barring accidental cases wherein pickup and drop taxi will be given upto 100km). Taxi will be given to the number of people equal to legal capacity of the car.

Custody Services

If towing is delayed, or if the technician on spot is unable to fix your vehicle, MG Roadside Assistance will arrange for personnel to take custody of your vehicle.

Vehicle Recovery following an Accident

If your vehicle is unable to be mobilized following a road traffic accident, MG Roadside Assistance will organize to send a recovery vehicle to recover your vehicle from the accident site to the nearest authorized MG Comet EV Dealer.

Medical Coordination

In case of a medical assistance required by you during the breakdown, MG Roadside Assistance team will help for the medical coordination.

Accommodation Assistance

In case of a breakdown occurring outside customer's home city / vehicle being towed outside home city, and if so needed by you, MG Roadside Assistance will help provide a hotel accommodation for you for one night for the number of people equal to legal capacity of the car.

Program Overview – Definitions

• Covered Customers:

The owner (or driver) and all the passengers travelling in the vehicle at the moment the roadside assistance was required, up to the legal passenger limit of the vehicle. The customer may be asked to produce car/other identity documents to verify the eligibility under this Program.

• Covered Vehicles and period of cover:

All new MG vehicles sold by Authorised MG Dealers in India are eligible for free MG Roadside Assistance with Pan India coverage (except islands, areas with limited entries). Vehicles will be covered under this program for a period equal to applicable New Vehicle Warranty from the date of sale of the vehicle.

Assistance will be provided no matter where you are (i.e. at home, on the roadside, on the highways, in parking lot, etc.), as long as you are not already at an Authorized MG Comet EV Dealer.

Non-covered Events

MG Roadside Assistance is designed to help only in “covered events” that lead to stoppage / immobilization of your vehicle. As a result, this program will not cover following events, including but not limited to:

- Speedometer not working
- Air-conditioning is not working
- Passenger door(s) cannot be opened when there are no passengers in the vehicle
- Boot cannot be opened
- Front and / or rear demisters are not functioning
- Horn is not functioning
- Damaged door mirrors
- Rear view mirror is damaged, but it does not obstruct the driver's vision
- Windows cannot be opened
- Windows cannot be closed but weather conditions are fair, and the vehicle is not exposed to any security risk
- Seat adjustor is faulty, but the vehicle can be safely driven
- Passenger seat belts are faulty but there are no passengers in the vehicle
- Faulty security system unless the vehicle is immobilized or unless the alarm is sounding continuously
- ABS lights are illuminated
- Air bag warning lights are illuminated
- Traction control lights are illuminated
- Other non-safety related lights/service

warnings are illuminated

- Vehicle runs out of windscreen wiper fluid
- Front or rear windscreen wipers faulty but weather conditions are fair

General Exclusions

The following scenarios are general exclusions under the MG Roadside Assistance and therefore MG Roadside Assistance will not be responsible for any assistance costs as a result of any of the following:

- Vehicle is involved in motor racing, rallies, speed or duration tests, practice runs, or operated outside, subject to the exclusivities provided herein and in the owner manual;
- Assistance is required as a result of wars, riots, uprising, mass political demonstrations, pillage, strike, use for military purposes or acts of terrorism, earthquake damage, freak weather conditions, atmospheric phenomena, nuclear transformation phenomena or radiation caused by artificial acceleration of atomic particles;
- Breakdown is caused by deliberate damage, or participation or abetment in a criminal act or offence;
- The immobilization is resulting from damage caused by intervention of the police or other authorities;

- Any damage resulting from the use of the vehicle against the recommendations of the owner manual;
- Any consequential costs and / or damage to property as a result of a breakdown;
- Vehicles kept in a non-roadworthy condition or not serviced in accordance with the manufacturer's recommendations;
- The damage / immobilization is caused due to any repair work done on the vehicle is from a workshop which is not a member of the Authorized MG EV Workshop Network;
- The damage / immobilization is caused to the vehicle due to the negligence / intentional driving of the vehicle or tampering with the vehicle, even after becoming aware of the breakdown / fault / damage.
- If the vehicle identification number (VIN) of an insured vehicle is declared as total loss by the Insurer, the Roadside Assistance (RSA) provided in respect of such vehicle shall become null and void with effect from the date VIN of such vehicle is declared as total loss by the insurer.

General Terms and Conditions Remain with your Vehicle

- Once you have called MG Roadside Assistance, it is vital that you stay with your vehicle. Should the MG Roadside Assistance representative arrive at your vehicle while it is unattended, the necessary work will not be carried out.

Adverse Weather

- On occasion, adverse weather conditions such as floods, heavy rain, thunder / lighting, other natural calamities or other external factors may affect our ability to provide services and it may become physically impossible to assist you until the weather improves. During such times, our main priority will be to ensure that you and your passengers are taken to a place of safety; the recovery of your vehicle may not be possible until weather conditions permit.

External Factors

- MG will take every effort to reach you once you make the call however external conditions (including traffic, strike etc.), could delay such an effort.

Locked Keys

- Whilst we will always endeavour to provide assistance by the most efficient method, modern security systems sometimes make it extremely difficult for us to gain entry to your vehicle at the roadside. If a forced emergency entry is required, you will be asked to sign a declaration stating that you have granted permission for this to take place and confirming that all costs relating to any resulting damages to your vehicle will be your sole responsibility.

Replacement Costs

- The replacement cost for any damaged part of the vehicle shall not be covered by MG Roadside Assistance, unless it is covered under any other warranty(ies) provided by MG Motor, including the new vehicle warranty, as may be applicable and / or subscribed to by the owner of the MG vehicle.

Right of Refusal

- MG Roadside Assistance shall have the right to refuse any or all benefits under the program, if it is found that you had furnished false information relating to your eligibility or entitlements to the benefits provided under this program.

Disputes

- Courts situated within the jurisdiction of Gurugram alone shall have the exclusive jurisdiction to decide all disputes that may arise under this service.

Service Coupon



MORRIS GARAGES
Since 1924

Dear Customer,

We are confident that you and your family would be enjoying the safe and comfortable drive of the MG Comet EV.

We would like to undertake a thorough check-up of the vehicle at 1000 kms or 30 days, whichever occurs earlier. This will also allow us to re-emphasize the salient features of the MG Comet EV to you.

In the unlikely event of an emergency assistance, please call your nearest MG Dealer as mentioned in this booklet or please feel free to call our 24 x 7 pulse hub at 1800 100 6464

I confirm that the vehicle has been inspected by me and delivered to my satisfaction. I do abide by MG terms & conditions laid forward for warranty and other vehicle maintenance details.

Customer's Signature

Dealer Stamp & Signature

PDI (One day before delivery)

VIN _____

Drive Motor No. _____

PDI No. _____

Date of Delivery _____

Dealer Name _____

Dealer Code _____

Customer Name _____

Contact No. _____

Customer's Signature

Dealer Stamp & Signature

Service Coupon

1st Free Inspection
1 Month / 1000 km (whichever occurs earlier)

Carry out inspection as recommended at 1 month / 1000 km service as per periodic maintenance schedule.

Customer's Signature

Dealer Stamp & Signature

MG Motor Inspection

1st Free Inspection
1 Month / 1000 km (whichever occurs earlier)

VIN _____

Drive Motor No. _____

Regn. No. _____

Delivery Date _____

Date of Service _____

Kms (Odometer Reading) _____

I confirm that the job has been attended to my satisfaction.

Customer's Signature

Dealer Stamp & Signature

Service Coupon

2nd Free Inspection
6 Month / 5000 km (whichever occurs earlier)

Carry out inspection as recommended at 6 month / 5000 km service as per periodic maintenance schedule.

Customer's Signature

Dealer Stamp & Signature

MG Motor Inspection

2nd Free Inspection
6 Month / 5000 km (whichever occurs earlier)

VIN _____

Drive Motor No. _____

Regn. No. _____

Delivery Date _____

Date of Service _____

Kms (Odometer Reading) _____

I confirm that the job has been attended to my satisfaction.

Customer's Signature

Dealer Stamp & Signature

Service Coupon

3rd Free Inspection
1 Year / 10000 km (whichever occurs earlier)

Carry out inspection as recommended at 1 Year / 10000 km service as per periodic maintenance schedule.

Customer's Signature

Dealer Stamp & Signature

MG Motor Inspection

3rd Free Inspection
1 Year / 10000 km (whichever occurs earlier)

VIN _____

Drive Motor No. _____

Regn. No. _____

Delivery Date _____

Date of Service _____

Kms (Odometer Reading) _____

I confirm that the job has been attended to my satisfaction.

Customer's Signature

Dealer Stamp & Signature

Change of Ownership Record

Model _____

Registration or
License Number | | | | | | | | | | | | | | | | | | | | | |

VIN _____

Drive Motor No _____

New Owner's Name _____

New Owner's Address _____

Telephone No. _____



If resold by MG Motor Dealership
Enter Dealer Stamp in Box above

Maintenance Interval

Preventive Maintenance Schedule for Normal Operation

		1 Month	6 Month	1 Year	2 Year	3 Year	4 Year	5 Year	6 Year	7 Year	8 Year
Maintenance Operations	Replacement Frequency: Km / year whichever is earlier	1000	5000	10000	20000	30000	40000	50000	60000	70000	80000
Replacement, Check, and Repair											
Reducer fluid- Replacement (as per frequency defined), inspection (for leakage).	As defined	I	R	I	I	I	I	I	I	I	R
Brake fluid.	As defined	I	I	I	I	R	I	I	R	I	I
A/C filter element.	As defined	I	I	R	C	C	C	R	C	C	C
Lubrications of door locks, and stopper.	Inspection only	L	L	L	L	L	L	L	L	L	L
Vehicle Interior and Exterior											
Check the function of the parking brake.	Inspection only	I	I	I	I	I	I	I	I	I	I
Check the interior and exterior lighting, horn and system warning display functions.	Inspection only	I	I	I	I	I	I	I	I	I	I
Check the surfaces of windscreen and rear window, and the working condition of wipers and washers.	Inspection only	I	I	I	I	I	I	I	I	I	I
Check the status and function of seat belt.	Inspection only	I	I	I	I	I	I	I	I	I	I
Check various control functions of A/C.	Inspection only	I	I	I	I	I	I	I	I	I	I
Check the conditions of front compartment cover lock, tailgate lock, door locks, hinges, door checks, etc., clean up all the dust and refill lubricating grease as necessary.	Inspection only	I	I	I	I	I	I	I	I	I	I

Symbol Abbreviation : R - Replace • I - Inspect- Top up if require-Adjust-Clean-Refill , L - Lubricate, C - Clean

** Tightening of underbody fasteners, door adjustments and functional checks of all the systems during every service is mandatory - Check and Rectify.

Fluid, Consumables, Grease, Components, Wheel Alignment, Wheel Balancing etc. (but not limited to mentioned) will be replaced on chargeable basis. Periodic Maintenance Schedule is for reference. MG reserves right to change the Periodic Maintenance Schedule. For latest Schedule, please refer MYMG APP / Website Owner's Manual.

Preventive Maintenance Schedule for Normal Operation

		1 Month	6 Month	1 Year	2 Year	3 Year	4 Year	5 Year	6 Year	7 Year	8 Year
Maintenance Operations	Replacement Frequency: Km / year whichever is earlier	1000	5000	10000	20000	30000	40000	50000	60000	70000	80000
Front Compartment											
Check the connection and status of 12V battery.	Inspection only	I	I	I	I	I	I	I	I	I	I
Check the high-voltage harness for mutual interference, wear or damage	Inspection only	I	I	I	I	I	I	I	I	I	I
Check the washer fluid level and add to the standard level as necessary.	Inspection only	I	I	I	I	I	I	I	I	I	I
Check the status of cooling system pipeline and connecting parts.	Inspection only	I	I	I	I	I	I	I	I	I	I
Check the status of A/C system pipeline such as the compressor, the cooling pipeline and the condenser, and clean relevant surfaces as necessary.	Inspection only	I	I	I	I	I	I	I	I	I	I
Check the status of brake vacuum booster and hose.	Inspection only	I	I	I	I	I	I	I	I	I	I
Check the drive motor mounting bracket.	Inspection only	I	I	I	I	I	I	I	I	I	I
Vehicle Bottom											
Check the appearance of high-voltage connector and if it is fitted properly; check the surface of high-voltage connector for damage and if it is fitted in place.	Inspection only	I	I	I	I	I	I	I	I	I	I
Check the high-voltage harness for mutual interference, wear or damage.	Inspection only	I	I	I	I	I	I	I	I	I	I

Symbol Abbreviation : R - Replace • I - Inspect- Top up if require-Adjust-Clean-Refill , L - Lubricate, C- Clean

** Tightening of underbody fasteners, door adjustments and functional checks of all the systems during every service is mandatory - Check and Rectify.

Fluid, Consumables, Grease, Components, Wheel Alignment, Wheel Balancing etc. (but not limited to mentioned) will be replaced on chargeable basis. Periodic Maintenance Schedule is for reference. MG reserves right to change the Periodic Maintenance Schedule. For latest Schedule, please refer MYMG APP / Website Owner's Manual.

Maintenance Interval

Preventive Maintenance Schedule for Normal Operation

		1 Month	6 Month	1 Year	2 Year	3 Year	4 Year	5 Year	6 Year	7 Year	8 Year
Maintenance Operations	Replacement Frequency: Km / year whichever is earlier	1000	5000	10000	20000	30000	40000	50000	60000	70000	80000
Vehicle Bottom											
Check the appearance of vent valve for damage, and check the marking for fitting to see if it is moved.	Inspection only	I	I	I	I	I	I	I	I	I	I
Check the marking for fitting the mounting bolt to see if it is moved and ensure the bolts are fastened.	Inspection only	I	I	I	I	I	I	I	I	I	I
Check the appearance of housing (including the bracket) for crack or deformation.	Inspection only	I	I	I	I	I	I	I	I	I	I
Check the appearance of high-voltage battery pack grounding wire and replace it as necessary.	Inspection only	I	I	I	I	I	I	I	I	I	I
Vehicle Interior and Exterior											
Check the status and thickness of front brake pads and brake disc, and rear brake liners and drum, and replace them as necessary.	Inspection only	I	I	I	I	I	I	I	I	I	I
Check brake pipes and hoses for condition and security. Ensure that hoses are not twisted or kinked.	Inspection only	I	I	I	I	I	I	I	I	I	I
Check the wheel bearings .	Inspection only	I	I	I	I	I	I	I	I	I	I
Check the suspension and steering system for leakage or wear.	Inspection only	I	I	I	I	I	I	I	I	I	I

Symbol Abbreviation : R - Replace • I - Inspect- Top up if require-Adjust-Clean-Refill , L - Lubricate, C- Clean

** Tightening of underbody fasteners, door adjustments and functional checks of all the systems during every service is mandatory - Check and Rectify.

Fluid, Consumables, Grease, Components, Wheel Alignment, Wheel Balancing etc. (but not limited to mentioned) will be replaced on chargeable basis. Periodic Maintenance Schedule is for reference. MG reserves right to change the Periodic Maintenance Schedule. For latest Schedule, please refer MYMG APP / Website Owner's Manual

Preventive Maintenance Schedule for Normal Operation

		1 Month	6 Month	1 Year	2 Year	3 Year	4 Year	5 Year	6 Year	7 Year	8 Year
Maintenance Operations	Replacement Frequency: Km / year whichever is earlier	1000	5000	10000	20000	30000	40000	50000	60000	70000	80000
Vehicle Interior and Exterior											
Check the tread depth to see if the tyre is worn or damaged abnormally. Check the four-wheel alignment data. Perform Tire rotation *(24 Months or 20,000 km)	Inspection only	I	I	I	I	I	I	I	I	I	I
Check the tyre pressure and make adjustment as necessary.	Inspection only	I	I	I	I	I	I	I	I	I	I
Check if the chassis and underbody bolts and nuts are fastened or fixed, and replace them as necessary.	Inspection only	I	I	I	I	I	I	I	I	I	I
After Maintenance and Repair											
Use diagnostic software to reset maintenance interval indicator. Check for fault codes and determine operation status of the control systems.	Inspection only	I	I	I	I	I	I	I	I	I	I
Check the status and function of communication module with the scan tool.	Inspection only	I	I	I	I	I	I	I	I	I	I
Carry out the road test, and check the status and function of power system, brake, steering and other systems.	Inspection only	I	I	I	I	I	I	I	I	I	I

Symbol Abbreviation : R - Replace • I - Inspect- Top up if require-Adjust-Clean-Refill , L - Lubricate, C- Clean

** Tightening of underbody fasteners, door adjustments and functional checks of all the systems during every service is mandatory - Check and Rectify.

Fluid, Consumables, Grease, Components, Wheel Alignment, Wheel Balancing etc. (but not limited to mentioned) will be replaced on chargeable basis. Periodic Maintenance Schedule is for reference. MG reserves right to change the Periodic Maintenance Schedule. For latest Schedule, please refer MYMG APP / Website Owner's Manual.

ANDHRA PRADESH

- MG Vijayawada**
Jayalakshmi Auto Enterprises Pvt. Ltd.
- 3S Door # 1-136/3, Gudavalli Junction, NH 16 Service Road, Gudavalli, Vijayawada - 521104
- MG Vijayawada Bodyshop**
Jayalakshmi Auto Enterprises Pvt. Ltd.
- 2S Door no 3-142, Gudavalli Junction , NH-16, Vijayawada Rural Mandal , NTR District, Gudavalli Junction, Andhra Pradesh 521104
- MG Vijayawada Guntur**
Jayalakshmi Auto Enterprises Pvt. Ltd.
- Z-Next 3S
No. 36, Phase IV Autonagar, Next to Royal Enfield Showroom, Guntur - 522001
- MG Vizag**
Tristar Auto Agencies (Vizag) Pvt. Ltd.
- 1S Beside Kali Matha Mandhir, RK Beach Junction, Visakhapatnam - 530002
- MG Vizag Service**
Tristar Auto Agencies (Vizag) Pvt. Ltd.
- 2S Plot No. D-36, Industrial Estate, Marripalem, Visakhapatnam - 530018
- MG Tirupati**
Keshvin Auto Motors Pvt. Ltd.
- 3S 717/B2F1, 200 Feet By-Pass Road, Thukivakam, Tirupati - 517501

- MG Tirupati Kadapa**
Keshvin Auto Motors Pvt. Ltd.
- 1S 96/3-157-3-A National highway : 44, Mamidalapadu Beside eenadu office, Kurnool-518006
- MG Rajahmundry**
Jayalakshmi Auto Enterprises Pvt. Ltd.
- 3S 84-1-5/B, Padmavathi Nagar Opp: JN Road, NH5, Rajahmundry, Andhra Pradesh-533106
- MG Tirupati Nellore**
Keshvin Auto Motors Pvt. Ltd.
- Z-Next 3S
Sy No 525/2 Buranpur, Nellore-Chennai bypass, Bhuj Nellore
- MG Tirupati Kurnool**
Keshvin Auto Motors Pvt. Ltd.
- Z-Next 3S
96/3-157-3-A National highway:44, Mamidalapadu Beside eenadu office, Kurnool-518006
- MG Tirupati Ananthapur**
Keshvin Auto Motors Pvt. Ltd.
- Z-Next 3S
1-1348-1, Opposite Sakshi Office, Anantapur -515001

ASSAM

- MG Guwahati**
Karini Ventures Pvt. Ltd.

- 1S Royal Orchid, NH37, Near Garchuk Police Station, Garchuk, Dhirenpara, Guwahati - 781035
- MG Guwahati Service**
Karini Ventures Pvt. Ltd.
- 2S AK Deb Road, Katabaril, Gorchuk, NH 37, Guwahati - 781035
- MG Guwahati Dibrugarh**
Karini Ventures Pvt. Ltd.
- Z-Next 3S
AT Road, Opposite Thermal Power Station, Dibrugarh - 786001

BIHAR

- MG Patna**
Ashiana Fabicon Pvt. Ltd.
- 1S Ground Floor, "Ashiana Vihar" Apartment, Near CDA Building, Rajendra Path, Patna - 800001
- MG Patna Workshop**
Ashiana Fabicon Pvt. Ltd.
- 2S Anisha Bad Main, Patna - 800 002
- MG Patna Muzaffarpur**
Ashiana Fabicon Pvt. Ltd.
- Z-Next 3S
Shakri Saraiya, Bihar - 843165
- MG Patna Patliputra**
Ashiana Fabicon Pvt. Ltd.

2S C12-1, Patliputra Industrial Area, Patliputra Colony, Patna, Bihar-800013

CHHATISGARH

**MG Raipur
Shivaaya Cars Pvt. Ltd.**

3S Ring Road No.1, Raipura, Raipur-492099

**MG Bilaspur
Shivaaya Cars Pvt. Ltd.**

3S MG Motors Bilaspur, NH 130, Raipur Main Raod, Sirgitti, Bilaspur, Chhattisgarh,

**MG Bilaspur - Ambikapur
Shivaaya Cars Pvt. Ltd.**

ESN Industrial Estate Near Holly Cross School, Beside of Laxmi Borwell Banaras Road Ambikapur Distt. - Surguja (C.G.) 497001

DELHI

**MG Delhi South Safdurjung
Sai Shreeja Cars Pvt. Ltd.**

IS B-1/4, Safdarjung Enclave Delhi - 110029

**MG Delhi West Shivaji Marg
MG Cars Pvt. Ltd.**

IS Plot no 31, Najafgarh Road, Industrial Area, Shivaji Marg, New Delhi - 110015

**MG Lajpat Nagar
Sai Shreeja Cars Pvt. Ltd.**

EC A-14, Ring Road, Lajpat Nagar- IV, New Delhi - 110024

**MG Delhi North West Rohini
MG Cars Pvt. Ltd.**

EC AI/1, Prashant Vihar Outer Ring Road N.D - 110085

**MG Delhi South Okhla
Sai Shreeja Cars Pvt. Ltd.**

2S B-67, Phase-1, Okhla, New Delhi - 110020

**MG Patparganj
Crystal Autocars Pvt. Ltd.**

EC Plot No 24, Block No 1, Functional Industrial Estate, Patparganj, Delhi - 110092

**MG Delhi West Kirti Nagar
MG Cars Pvt. Ltd.**

2S 7/20, Kirti Nagar, Ind Area, Delhi - 110015

**MG Okhla Bodyshop
Sai Shreeja Cars Pvt. Ltd.**

2S D-1, Okhla Industrial Area, Phase -1, New Delhi - 110 020

**MG North Jahangirpuri Service
(Mechanical+Bodyshop)
MG Cars Pvt. Ltd.**

2S Plot No. 5, Small Scale Co-operative Industrial Area, G.T Karnal Road, Delhi

**MG Delhi West - Kirti Nagar Bodyshop
MG Cars Pvt. Ltd.**

2S 9/48, Kirti Nagar Industrial Area, Delhi-110015

**MG Delhi South - Mathura Road (MCIE)
Sai Shreeja Cars Pvt. Ltd.**

IS Plot No.A-18 Block B-1 Mohan Cooperative Industrial Estate Mathura Road N.D.-110044

**MG Delhi West - Dwarka
MG Cars Pvt. Ltd.**

IS A-19, Defense Enclave, Raja Puri Road, Dwarka, New Delhi, Delhi-110059

GOA

**MG Goa
Aeromark Cars Pvt. Ltd.**

IS Survey No.166/1, New Taleigao bypass road, Opp. Taleigao Community Centre. Taleiga-Goa - 403002

**MG Goa Service
Aeromark Cars Pvt. Ltd.**

2S Survey No.132/1-C, Behind Healthway Hospital, SE Old Goa, Tiswadi Goa - 403108

**MG Goa Margao
Aeromark Cars Pvt. Ltd.**

ESN Plot No U02-J and U02-K, Phase 4, Verna Industrial estate,, Verna, Goa 403722

GUJARAT

**MG Ahmedabad SG Highway
Concept Motor Garage Pvt. Ltd.**

- IS Plot No 2, Ground Floor, Survey No 841/1 and 2, 10, Signature I, Near Old Railway Line, SG Highway, Makarba, Ahemdabad - 380051

**MG Surat
Nanavati Autosquare Pvt. Ltd.**

- IS Ground Floor, Icon Business Centre, Opposite Central Mall, Piplod Dumas Road, Surat - 395007

**MG Surat Bodyshop
Nanavati Autosquare Pvt. Ltd.**

- 2S 339, Bhatpore GIDC, Behind Nanavati Toyota, Magdalla Hazira Road, Ichchhapor, Surat - 394510

**MG Surat Bharuch
Nanavati Autosquare Pvt Ltd**

- Z-Next 3S
LS56/A, NR, Reliance Petrol Pump NH08, Vagusana, Bharuch-393010

**MG Vadodara
Kayakalp Cars Pvt. Ltd.**

- IS Zorba, Akshara Chowk, OP Road, Vadodara - 390012

**MG Vadodara Service
Kayakalp Cars Pvt. Ltd.**

- 2S 362 GIDC Makarpura, Vadodara-390010

**MG Vadodara Bodyshop
Kayakalp Cars Pvt. Ltd.**

- 2S Plot 885, GIDC Makarpura, Vadodara, Gurjarat 390010

**MG Vadodara Anand
Kayakalp Cars Pvt. Ltd.**

- Z-Next 3S
Near Jay Ambe Nagar Society, Rajodpura, Chikhodra, Gujarat 388001

**MG Rajkot
Jai Ganesh Autocars Pvt. Ltd.**

- IS Jai Ganesh MG. Opp Krishna Park, Rajkot-Gondal Highway, Kothariya, Rajkot - 360003

**MG Rajkot
Jai Ganesh Autocars Pvt. Ltd.**

- 2S Jai Ganesh MG, Near Jagannath Marble, Rajkot Gondal Highway, Kothariya, Rajkot-360003

**MG Rajkot Bhavnagar
Jai Ganesh Autocars Pvt. Ltd.**

- 2S Plot No: 404, Rajkot-Bhavnagar Highway, Opp:Viraj Farm, Vartej-Bhavnagar - 364060

**MG Rajkot Jamnagar
Jai Ganesh Autocars Pvt. Ltd.**

- Z-Next 3S
Opp: Yamuna Petroleum, Hapa Industrial Area, Rajkot-Jamnagar Highway, Hapa-Jamnagar - 361120

**MG Rajkot Gandhidham
Jai Ganesh Autocars Pvt. Ltd.**

- Z-Next 3S
122, Rabindranath Tagore Rd, Ward 5, Adipur, Gandhidham - 370205

**MG Vapi
Nanavati Autosquare Pvt. Ltd.**

- 3S Survey No 56/1/1, Opp Avadh Utopia, NH-8, Salvav, Vapi, Tal-Pardi, Dist-Valsad - 396195

**MG Gandhinagar
Concept Motor Garage Pvt. Ltd.**

- IS Plot No 29 Old GTS Road NR Thermal Power Station Sector 30 Gandhinagar

**MG Gandhinagar Service
Concept Motor Garage Pvt. Ltd.**

- 2S Survey No. 600, Nr.Valad, Gandhinagar - 382355

**MG Gandhinagar Himmatnagar
Concept Motor Garage Pvt. Ltd.**

- Z-Next 3S
Survey no 97/3, N.H No.8, Piplodi, Himmatnagar, 383001

**MG Ahmedabad Naroda
Concept Motor Garage Pvt. Ltd.**

- EC GF-4, Neelkanth Square, Nr.Railway Crossing, NH8, Naroda, Ahmedabad - 382330

**MG Ahmedabad Ring Road
Concept Motor Garage Pvt. Ltd.**

2S Survey No 321, Anuj Estate, Opp. Essar Petrol Pump, S.P. Ring Road, Sanathal Ahmedabad - 382210

MG Ahmedabad Central Ambawadi Concept Motor Garage Pvt. Ltd.

1S GF, Ashwamegh Elegance, Opposite SBI Zonal Office, Ambawadi, Ahmedabad

MG Mehsana Concept Motor Garage Pvt. Ltd.

Z-Next 3S

Near Celebration Party Plot, Opposite Green Meadows, Ahmedabad – Mehsana Highway, Mehsana - 384002

MG Ahmedabad Central - Gota Mech Concept Motor Garage Pvt. Ltd.

2S Nr. Dhaval farm, Opp.S.G.Business Hub, Gota, Ahmedabad, Gujarat- 382481

HARYANA

MG Gurgaon Flagship Showroom Cargo Motors (Kutch) Pvt. Ltd.

1S Sector 15 Part 2, Gurugram, Haryana 122022

MG Gurgaon Flagship - Narsinghpur Cargo Motors(Kutch) Pvt. Ltd.

2S Sector 74A, Gurugram - 122001

MG Gurgaon Central Cargo Motors(Kutch) Pvt. Ltd.

1S Double Tree by Hilton, Golf Course Road, X sector-56, Gurgaon

MG Gurgaon Central (IDC) Mech Cargo Motors(Kutch) Pvt. Ltd.

2S A-17, Industrial Development Area, Sector 16, Gurugram, Haryana-122007

MG Gurgaon Flagship - Rewari Cargo Motors(Kutch) Pvt. Ltd.

ESN Ward No. 5, Opposite Madhusudan School, Delhi Road, Rewari - 123035

MG Karnal Rahul Garages LLP

3S Adjoining Sudhanshu ji Maharaj Ashram, Near Devi Lal Chowk, Karnal

MG Karnal Yamuna Nagar Rahul Garages LLP

Z-Next 3S

Opp. Bharat Dharam Kanta, Kissan Pura, Yamunanagar Road, Damla, Yamunanagar, Haryana, 135001

MG Panipat Rahul Garages LLP

1S Near HUDA Office, Sector 18, G.T Road, Panipat

MG Panipat Service Rahul Garages LLP

2S Behind Radha Swami Satsang Bhawan, Sector 18, Panipat

MG Sonipat MG Cars Pvt. Ltd.

3S Opposite Ashoka University, Sector 37, GT Road, Sonipat

MG Ambala Service Gitansh Motors Pvt. Ltd.

3S 9 KM Stone, Village Khuddi, Jagadhari Road, Cantt, adjoining Elegant Honda, Ambala

MG Rohtak Lohchab Autocar Pvt. Ltd.

1S 4 KM Stone, HSIIDC Industrial Area, Rohtak-Hisar Road, Rohtak - 124001

MG Rohtak Service Lohchab Autocar Pvt. Ltd.

2S 8 KM Stone, Rohtak-Hisar Road, Village Bahu-Akbarpur, Rohtak - 124001

MG Hisar Gitansh Motors Pvt. Ltd.

3S 14.5 Milestone NH65, Chandigarh Road, Hisar - 125006

MG Faridabad Cargo Motors(Kutch) Pvt. Ltd.

3S 14/6, Mathura Rd, Pocket B, Sector 27, Faridabad

MG Faridabad Cargo Motors(Kutch) Pvt. Ltd.

ES 14/6, Mathura Rd, Pocket B, Sector 27, Faridabad

HIMACHAL PRADESH

MG Mandi Service Krishna Motor Garage

- 3S Vill.Lunapani PO Bhangrotu The, Balh Distt,
Mandi - 175021

JAMMU & KASHMIR

MG Jammu Arise Autoz Pvt. Ltd.

- 1S Bypass Road, Thangar, Channi Himmat,
Jammu, Pin 180015

MG Jammu Service Arise Autoz Pvt. Ltd.

- 2S Malik Market, Narwal Bypass Jammu - 180016

MG Srinagar Arise Autoz Pvt. Ltd.

- 3S Tangpora Bemina Bypass Near Arise Hyundai,
Srinagar

MG Srinagar Anantnag Arise Autoz Pvt. Ltd.

- Z-Next 3S
NH-1A, , Uranhall, Anantnag, Jammu and
Kashmir-192101

JHARKHAND

MG Ranchi Singhania Future Pvt. Ltd.

- 1S Near Firayalals Pulsar Plaza, Line Tank Rd,
Ranchi - 834001

MG Jamshedpur Singhania Future Pvt. Ltd.

- 3S Plot No 229 Usha More, Tata Kandra Main
Road, Gamharia SariaKella Kharsawan,
Jamshedhpur - 832108

MG Dhanbad Singhania Future Pvt. Ltd.

- 3S G.T.Road, At Gahira Nirsa Road, Govindpur,
Gahira, Dhanbad - 828109

MG Dhanbad Dhansar Chowk Singhania Future Pvt. Ltd.

- EC Beside JCB Showroom, Nr Radha Krishna
Mandir, Dhansar Chowk, Dhanbad - 828106

MG Ranchi Service Singhania Future Pvt. Ltd.

- 2S NH-33, Chakla, Ormanjhi, Ranchi - 835219

KARNATAKA

MG Bangalore South-Electronic City Jubilant Motorworks Pvt. Ltd.

- 1S 195/6/2, Ward No 192, Beratena Agrahara,
Luv Kusha Nagar, Hosur Road,
Bangalore - 560100

MG Bangalore West-Kalyan Nagar Jubilant Motorworks Pvt. Ltd.

- 1S Property Bearing No.100/1 And Bearing
Site No.3, Now Come Within The Limites
Of BBMP Khata No.164, Situated At
Chikkathayappa Reddy Layout, First Cross,
Chelekere Village, Outer Ring Road,
Kalyanagar Post Bangalore - 560043

MG Mysore Dyuthi Automobiles Pvt. Ltd.

- 3S 201/1 & 201/2, Hinkal Village, Hunsur Road,
Mysore- 570017

MG Bengaluru Mysore Road Jubilant Motorworks Pvt. Ltd.

- 3S Survey No, 26/1B2, Kenchenahalli, 12th KM
Mysore Road, Bengaluru, Karnataka - 560059

MG Mysore Hasan Dyuthi Automobiles Pvt. Ltd.

- Z-Next 3S
54/1, Doddamandiganahally Village, B M Road,
Kandali Post, Hasan-573217

MG Hubli Bellad and Company Pvt. Ltd.

- 3S Bellad Enterprises Pvt Ltd, Opp NGEF,
Rayapur, PB Road, Hubli - 580025

MG Mangalore Jubilant Motorworks Pvt. Ltd.

- 3S Survey No. 38, Village, 2 Kuloor - Kavoore Rd,
Kuloor, Padukodi, Mangalore - 575013

**MG Bangalore South ORR
Jubilant Motorworks Pvt. Ltd.**

- EC Shree Bhuvanewari Vokkaligara Sangha,
Survey No 102-1, B Narayanapura, ORR,
Bangalore - 560016

**MG Bengaluru Central - JP Nagar
Jubilant Motorworks Pvt. Ltd.**

- EC BBMP New Municipal No.14, Situated at 100
Feet Road, 4th Phase, J.P. Nagar, BBMP Khata
Bearing PID No. 57-116-14, Bangalore-560078

**MG Bangalore West-Chord Road
Jubilant Motorworks Pvt. Ltd.**

- EC Site Bearing No. 84 (old No.32), Situated at
20th Main, II-Block, in Rajajinagar Extension,
Ward No.15, BBMP Khata bearing PID No.15-
12-84, Bangalore - 560010

**MG Bengaluru South - Electronic City
Workshop
Jubilant Motorworks Pvt. Ltd.**

- 2S Workshop No.6/1-03-KTR/526, 15 KM Hosur
Rod, Hosur Main Road, Bangalore-560100

**MG Bengaluru West - MVIT Workshop
Jubilant Motorworks Pvt. Ltd.**

- 2S MVIT Workshop- Sy No.32/33, Nellukunte
Village, Jalahalli Hobli, Now Yelahanka Taluk,
MVIT College Road, Hunasamaranahalli Post,
Bangalore-562157

**MG Bengaluru Central - Mahadevpura
(Mechanical)
Jubilant Motorworks Pvt. Ltd.**

- 2S No.505 (Old No. 501/7), Puttappa Industrial
Estate, Mahadevpura, Bengaluru

**MG Bangalore Central
Jubilant Motorworks Pvt. Ltd.**

- 1S GF, 40/4, Lavelle Road,. Bangalore - 560001

**MG Hubli - Belgaum
Bellad and Company Pvt. Ltd.**

- Z-Next 3S
Shrikrishna Weaving Mill Compound, Vengurla
Road, Vijaynagar, Belgaum - 591108

**MG Hubli - Gulbarga
Bellad and Company Pvt. Ltd.**

- Z-Next 3S
Near Avinash Petrol Bunk,Kapnoor Industrial
Area, 1st Stage,Humanabad Road

**MG Mangalore - Udupi
Jubilant Motorworks Pvt. Ltd.**

- Z-Next 3S
survey no. 58/4B3 and property ID No.7-2-3-
46C-0-1 & 7—2-3-46 C-0-2

**MG Shimoga
Cauvery Motors Private Limited**

- 1S Shankar Mutt Road, Shimoga-577201

**MG Shimoga
Cauvery Motors Private Limited**

- 2S No.7 & 8, KSSIDC Limited, Industrial Estate,
NT Road, Mandli, Shimoga 577 202

**MG Bengaluru South - Tumkur
Jubilant Motorworks Private Limited**

- ESN Khata No.3803/10/3061, PID no.66883,
situated SIRA Road, Tumkur , Tumkur City

KERALA

**MG Kottayam
CoastLine Garages India Pvt. Ltd.**

- 3S XII/801-B, Opp. St. Mary's Chapel, MC Road,
Thellakom P.O., Kottayam - 686630

**MG Kottayam
CoastLine Garages India Pvt. Ltd.**

- 3S 12/72 C, Near Wexco villa, MC Road,
Thellakom P.O., Kottayam-686630

**MG Calicut
CoastLine Garages India Pvt. Ltd.**

- 1S Opposite West Hill Post Office, Kannur Road,
West Hill P.O, Calicut - 673005

**MG Thrissur
CoastLine Garages India Pvt. Ltd.**

- 3S Near Palliakara Toll Plaza, NH-47,
Menmankiara Chitissery PO
Thrissur - 680301

**MG Thrissur - Palakkad 1S
CoastLine Garages India Pvt. Ltd.**

Z-Next 1S

XXIII/948-42, Near Federal Bank,
Kunnathoormedu, Coimbatore Road,
Palakkad-678013.

**MG Thrissur - Palakkad 2S
CoastLine Garages India Pvt. Ltd.**

Z-Next 2S

NH Service Road, Near Medical College,
Kadamkode, Palakkad, Kerala - 678013

**MG Trivandrum Central
Fortune Malayalam Automobiles Pvt.
Ltd.**

1S TC 86 /1431(2), NH Bypass – Airport Road ,
Chackai, Thiruvananthapuram, Kerala 695024

**MG Trivandrum Central
Fortune Malayalam Automobiles Pvt.
Ltd.**

2S Building No 10/1362, 10/1363, 10/1364,
Peroorkada, Vattiyoor kavu Road, Trivandrum
- 695013

**MG Calicut
CoastLine Garages India Pvt. Ltd.**

2S Puthukode Road, Parammal Azhinhilam,
Ramanattukara, Calicut - 673633

**MG Calicut Malappuram
CoastLine Garages India Pvt. Ltd.**

Z-Next 3S

Aripa Post, Thirurkad, Aripa Schoolpadi,
Malapurram - 679321

**MG Kannur
Fortune Malayalam Automobiles Pvt.
Ltd.**

3S XXIX / 775 / I ,Near SN College ,Thottada ,
Kannur - 670007

**MG Kannur Kollam
Fortune Malayalam Automobiles Pvt.
Ltd.**

Z-Next 3S

585/11-2, NH-QS Road, Kilikolloor,
Kallumthazam, Kollam 691004

**MG Cochin
CoastLine Garages India Pvt. Ltd.**

3S Opposite Metro Pillar no 155 , NH 47,
Muttom , Near Aluva , Cochin-683106

**MG Kottayam - Allepy
CoastLine Garages India Pvt. Ltd.**

ESN 8/511-B, Mararikulam, Kalavoor, Opp Valiya
Kalavoor Temple, Alappuzha, Kerala - 688522

MADHYA PRADESH

**MG Indore
Aeromark Cars Pvt Ltd**

1S 1/2, Anoop Nagar AB Road, Shree Nagar Main
Colony, Indore 452001

**MG Bhopal
Aeromark Cars Pvt Ltd**

1S Plot No, 4056, Narmadapuram Rd, near Shiv
Mandir, Adarsh Nagar, Ahmedpur Kalan,
Bagmugaliya, Hoshangabad Road, Bhopal
462026

**MG Bhopal
Aeromark Cars Pvt Ltd**

2S Plot No. 473/1, Opposite International
Public School, 11 Mile, Village Bhairampur,
Hoshangabad Road, Bhopal 462047

**MG Gwalior
Sumedha Vehicles Pvt. Ltd.**

3S Shivpuri Link Road, Village Kedarpur,
Gwalior - 474001

**MG Jabalpur
Khatwani Motors Pvt. Ltd.**

3S 1142, opp. Bhasin arcade, Axis Bank, Prem
Nagar, Nagpur Road, Madan Mahal,
Jabalpur - 482002

**MG Indore
Aeromark Cars Pvt. Ltd.**

2S Plot no 30/2, Opposite Isuzu Lasudiya Mori
Dewas Naka, Near Toll Kata, Indore - 453771

**MG Ratlam
Hriday Cars Pvt. Ltd.**

3S 13/4 Salakhedi, Mhow Neemuch Road, Ratlam,
Madhya Pradesh 457001

**MG Chhindwara
Patodi Automobiles Pvt Ltd**

1S Near Sony Show Room, Nagpur Road,
Chhindwara, Madhya Pradesh 480001

**MG Chhindwara
Patodi Automobiles Pvt Ltd**

2S In front of Water Stone Restaurant Nagpur
Road, Devardha, Chhindwara

**MG Bilaspur - Ambikapur
Shivaaya Cars Pvt Ltd**

1S Manedragarh Road, Ambikapur, Chhattisgarh,
497001

**MG Jabalpur - Shahdol
Khatwani Motors Pvt Ltd**

ESN BY Pass Road NH- 78, Burhar Road, Near
Old Tata Workshop- Shahdol, 484001

**MG Jabalpur - Satna
Khatwani Motors Pvt Ltd**

ESN 1168, Kripalpur, Rewa Road, Satna, 485001

**MG Jabalpur - Chhatarpur
Khatwani Motors Pvt Ltd**

ESN Ward-32 Near New Panna Naka,
Chhatarpur, 471405

MAHARASHTRA

**MG Mumbai South
Krishiv Auto Agencies Private Limited**

1S Floor G-2, Plot No. 1086, Electric Mansion,
Appasaheb Marathe Marg, Prabhadevi, Mumbai
- 400025

**MG Mumbai West
Krishiv Auto Agencies Private Limited**

3S CTS 227, Service Road, Near Junction of JVLR
& Western Express Highway, Gupha Tekdi,
Opp. Balsaheb Thackrey Hospital, Jogeshwari
(East), Mumbai - 400063

**MG Thane
Tejpal Motors Pvt. Ltd.**

1S Shop No 16, Dosti Imperia, Ghodbunder
Road, Thane West - 400610

**MG Pune Wakad
B.U. Bhandari Auto Pvt. Ltd.**

3S Survey No 142, Hissa No 1+2/5, Wakad,
Mumbai Bangalore Highway, Pune - 411057

**MG Nagpur
Nangia Cars Pvt. Ltd.**

3S 33B 1/4 Hingna MIDC Opp Nangia Speciality
Hospital Nagpur - 440028

**MG Kolhapur
Unique Automobiles Maharashtra Pvt.
Ltd.**

1S S.No 592, H.No 4481 1st Stop MIDC
Shiroli(P) Tal-Hatkanangale, Dist-Kolhapur -
416122

**MG Nasik
Jitendra Wheels (N) Pvt. Ltd.**

1S B-88 MIDC Ambad, Mumbai Agra Highway,
Next to Hotel Gateway, Nashik- 422010

**MG Aurangabad
Dhoot Motors Autotech Pvt. Ltd.**

1S ABC Complex, Adalat Road,
Aurangabad - 431005

**MG Pune East - Pune Central
B.U. Bhandari Auto Pvt. Ltd.**

1S 2422, General Thimayya Road, East Street
Camp, J William & Co, Pune - 411001

**MG Solapur
Gandhi Cars**

3S 75/5/1, Bale, Pune Road, Solapur - 413255

**MG Malad
Krishiv Auto Agencies Private Limited**

EC Shakti Premises, Near Inorbit Mall, New Link
Road, Ram Nagar, Malad (West) Opp. Cloud
Nine Hospital, Mumbai - 400064

**MG Navi Mumbai
Tejpal Motors Pvt. Ltd.**

3S Old Mahindra Showroom, Next to Auto Bahn
VW Showroom - 400706

**MG Navi Mumbai Bodyshop
Tejpal Motors Pvt. Ltd.**

2S Plot No D-239 MIDC TTC Industrial Area,
Shirvane, Navi Mumbai, Maharashtra-400706

- MG Thane Service
Tejpal Motors Pvt. Ltd.**
- 2S Western Extrusion Industries, Near Capital Hotel, Thane West - 400606
- MG Kolhapur Workshop
Unique Automobiles Maharashtra Pvt. Ltd.**
- 2S C/O-Choughle Machines Pvt. Ltd., A- 17/18, MIDC, Shirol, Kolhapur - 416122
- MG Nasik Service
Jitendra Wheels (N) Pvt. Ltd.**
- 2S P-11/2, Ambad MIDC, near Volkswagen Showroom, opp Lokmat office, Mumbai Agra Highway, Nasik - 422010
- MG Aurangabad Service
Dhoot Motors Autotech Pvt. Ltd.**
- 2S Adalat Road, Next to High Court, Aurangabad - 431005
- MG Malad Service
Krishiv Auto Agencies Private Limited**
- 2S CTS 301 of Village Valnai Near Mith Chowky Link Road, Malad, Mumbai - 400097
- MG Navi Mumbai (Mechanical)
Tejpal Motors Pvt. Ltd.**
- 3S Plot No 238, MIDC, TTC Industrial Area Vane Village, Navi Mumbai - 400607
- MG South Mumbai Service (Mechanical)
Krishiv Auto Agencies Private Limited**
- 2S MG South, Eastern Metle Works, Dattaram Lad Marg, Near Sita Sadan, Kalachowki, Byculla East - 400033
- MG Navi Mumbai Chembur
Tejpal Motors Pvt. Ltd.**
- 1S Natraj Compound, Dr. C. G. Road, Near Shivaji Maharaj Chowk, Chembur, Mumbai - 400074
- MG Jalgaon
Saraswati Unicorp LLP**
- 3S 248/2, Tarsod, Jalgaon - Bhusaval Highway, Jalgaon 425002
- MG Pune Wakkad - Baramati
B.U. Bhandari Auto Pvt. Ltd.**
- Z-Next 3S
Near by Dhone Ford, Nevse Basti, Morgaon Road, Baramati - 413102
- MG Nashik - Ahmednagar
Jitendra Wheels (N) Pvt. Ltd.**
- Z-Next 3S
Nagar Manmad Road, MIDC Near Gajanan Colony Chowk, Nav Nagapur, Ahmednagar
- MG Nagpur - Chandrapur
Nangia Cars Pvt. Ltd.**
- Z-Next 3S
MG Chandrapur, Plot No. X-12, Chandrapur (Tadali) Growth Centre, Chandrapur
- MG Aurangabad - Nanded
Dhoot Motors Autotech Pvt. Ltd.**
- Z-Next 3S
House No 542-I, Opposite Spinning Mill, near Sambhaji Sut Girni, Wajegaon, Nanded - 431602
- MG Kolhapur Satara
Unique Automobiles Maharashtra Pvt. Ltd.**
- Z-Next 3S
289/2, Wadhe-Satara Road, Near Pooja Petrol Pump, Wadhe, Maharashtra - 415011
- MG Nagpur Amravati
Nangia Cars Pvt. Ltd.**
- Z-Next 3S
MG Nagpur, MIDC B/33, Wadi Hinga Road Opposite Nangia Superspeciality, Nagpur-440028
- MG Aurangabad Latur
Dhoot Motors Autotech Pvt. Ltd.**
- Z-Next 3S
Sree Nagar, Latur MIDC - 413531
- MG Nashik Dhule
Jitendra Wheels (N) Pvt. Ltd.**
- Z-Next 3S
P-62, Avdhan MIDC, behind Botel Manas-424311
- MG Nashik - Shirdi
Jitendra Wheels (N) Pvt. Ltd.**
- ESN Shri Ganesh Auto Scan, Nagar- Manmad

Road, At post: Sakuri, Taluka Rahata, Dist: Ahmednagar. Pin-423107

**MG Surat
Nanavati Autosquare Pvt Ltd**

- 2S Plot # 220-328, Bhatpore GIDC, Behind Nanavati Toyota, Magdala Hazira road, Surat-394510

**MG Kolhapur - Sangli
Unique Automobiles Maharashtra Pvt Ltd**

- ESN C.S.No. 290 A/2, Vakhar Bhag, Sangli, Maharashtra - 416416

**MG Pune East - Hadapsar
B.U. Bhandari Auto Pvt Ltd**

- 3S Plot No. 50, Hadapsar Industrial Estate, Hadapsar, Pune, Maharashtra 411013

**MG Thane - Kalyan
Tejpal Motors Pvt Ltd**

- 1S Unit Nos. 2 and 3(pt) situated at Survey No.8, Ranjnoli Bhiwandi Thane Maharashtra-421302

**MG Thane - Dombivali
Tejpal Motors Pvt Ltd**

- 1S Shop No 1 Vaibhav Nagari Nr. Sai Hospital kalyan Shil Road Katai Village Dombivali (East), Thane, Maharashtra 421203

**MG Mumbai West - Vasai
Krishiv Auto Agencies Private Limited**

- 1S Shop No 1 & 2 Rajprabha Ind Estate Gr Floor Boidpada Sativali Road Vasai East, Palghar, Maharashtra 401208

MANIPUR

**MG Imphal
GMDS Motor Pvt. Ltd.**

- 3S Mantripukhri, Imphal, Manipur 795002

**MG Imphal Bodyshop
GMDS Motor Pvt. Ltd.**

- 2S Leikinhabhi-Koirengei Rd, Keikol, Manipur - 795115

**MG Imphal - Dimapur
GMDS Motor Pvt. Ltd.**

- Z-Next 3S
Near Skoda Showroom, Burma Camp, Dimapur, Nagaland 797112

**MG Imphal - Silchar
GMDS Motor Pvt. Ltd.**

- Z-Next 1S
Rongpur Part 4 near Sagarika Resort. P.O. - Rongpur, P.S. - Silchar, Assam 788009

**MG Imphal - Silchar
GMDS Motor Pvt. Ltd.**

- Z-Next 2S
Rongpur Part 1, near Alkathipur, Silchar, 788009

ODISHA

**MG Bhubaneswar
Empreo Wheels Private Limited**

- 3S Plot No. 86/88, Near Apex Institute of Technology & Management, Pahala, NH-16, Bhubaneswar - 752101

**MG Bhubaneswar - Angul
Empreo Wheels Private Limited**

- Z-Next 2S
NH 55 Telco Chowk Nuahata, Banarpal, Angul - 759128

**MG Bhubaneswar - Sambalpur
Empreo Wheels Private Limited**

- Z-Next 3S
Plot No. 231 C/o- Samal Equip At-Pardhiapali Po-Sankarma, Sambalpur Odisha

**MG Bhubaneswar - Balasore
Empreo Wheels Private Limited**

- Z-Next 3S
Plot No-914/1175/1565 C/o Samal Equip inf-Morden Engineering College, Nh-5 Khannager, Balasore

PUDUCHERRY

**MG Puducherry
FPL Vehicles Pvt Ltd**

- 3S No.1 Cuddalore, Puducherry ECR Main Road, Ariyankuppam , Puducherry-605007

PUNJAB

- MG Mohali Chandigarh - Elante Krishna Motor Garage**
- IS Ground Floor, business block, Elante Mall, Phase I Industrial Area, Chandigarh, 160002
- MG Ludhiana Gitansh Motors Pvt. Ltd.**
- 3S GT Road Jugiana, Adjoining Indian Oil Petrol Pump, Ludhiana - 141010
- MG Jalandhar Cargo Motors (Kutch) Pvt. Ltd.**
- 3S BSF Chowk, G.T. Road, Jalandhar - 144001
- MG Patiala Krishna Motor Garage**
- 3S Near Casba Resort, Rajpura Patiala Road, Patiala - 147001
- MG Amritsar Cargo Motors (Kutch) Pvt. Ltd.**
- IS Khasra No.-1248, VPO -Daburji, Near Golden Gate, GT Road, Amritsar - 143022
- MG Amritsar Service Cargo Motors (Kutch) Pvt. Ltd.**
- 2S Opp Bhagat Ford Service, Daburjee, Rampura Road, Amritsar - 143002
- MG Mohali Krishna Motor Garage**

- 3S Plot no 3, Janta Industrial Estate, Sector 82, SAS Nagar, Mohali - 160082
- MG Mohali Chandigarh - Bodyshop Krishna Motor Garage**
- 2S Plot No-72, Industrial Area, Phase-I, Chandigarh 160002
- MG Jalandhar - Hoshiarpur Cargo Motors (Kutch) Pvt. Ltd.**
- ESN Bharvain Road Near Ambay Velly, Hoshiarpur - 146001
- MG Jalandhar - Nawanshahar Cargo Motors (Kutch) Pvt. Ltd.**
- ESN Opp Civil Hospital, Chandigarh Road, Bill, Zethu Mazra Nawanshahr - 144514
- MG Ludhiana - Bhatinda Gitansh Motors Pvt. Ltd.**
- Z-Next 3S
OPP. - IVY Hospital Bhai Mati Das Nagar Bathinda Mansa Road, Bathinda - 151001

RAJASTHAN

- MG Jaipur - Tonk Road GPS Automobiles Pvt Ltd**
- IS Plot No. 2 & 3/4, Choudhary Charan Singh Colony, Tonk Road, Jaipur - 302029
- MG Jodhpur Ganpati Four Wheels Pvt. Ltd.**
- 3S Plot No - 18, Opp. Saras Dairy, Heavy Industrial Area, Jodhpur-342003
- MG Kota Om Automotors Pvt. Ltd.**
- IS Om Metal Infra projects Ltd. Spl I(A) IPIA Jhalawar Road, Near Anantpura Chauraha, Kota - 324005
- MG Kota Service Om Automotors Pvt. Ltd.**
- 2S Om Metal Infraprojects Ltd, Plot No.A 21-22 Industrial Area Estate, Kota - 324005
- MG Ajmer GPS Automobiles Pvt. Ltd.**
- 3S Khasra No. 45,46,47, Ajmer By Pass NH 8 Badliya Chouraha, Near Nareli Jain Temple, Ajmer - 305024
- MG Jaipur Ajmer Road GPS Automobiles Pvt. Ltd.**
- EC Near Bajaj Capital, G-3, Anukampa Tower, Church Road (M.I. Road), Gopalbari, Jaipur - 302001
- MG Jaipur Ajmer Road DCM GPS Automobiles Pvt. Ltd.**
- IS E-31, I I C, Rani Sati Nagar, Nirman Nagar, Brijjalpura, Jaipur, Rajasthan - 302019
- MG Jaipur Sitapur Service GPS Automobiles Pvt. Ltd.**

2S IT 22, EPIP Block 3, Sitapur Industrial Area,
RIICO - IA, Sitapur, Jaipur, Rajasthan 302022

MG Jaipur - Sikar
GPS Automobiles Pvt. Ltd.

ESN Near R.T.O, Jaipur - Jhunjhunu Bypass,
Sikar - 332001

MG Jodhpur Sri Ganganagar
Ganpati Four Wheels Pvt. Ltd

ESN Chak 3 ML, Suratgarh Rd, Hanumangarh -
335001

MG Udaipur Bhilwara
PPS Motors Private Limited

ESN E-31 Madav Nagar, Bhilwara - 311001

MG Udaipur
PPS Motors Private Limited

3S CP-6/CP-7, Madri Industrial Area - 313001

TAMIL NADU

MG Chennai Central - Anasalai
FPL Vehicles Pvt. Ltd.

1S Old No. 398 / New no. 824/1, Annasali
Nandanam, Chennai, Tamil Nadu, 600035

MG Coimbatore
PPS Motors Private Limited

3S No-138, Avinashi Road, Chinniyampalayam,
Coimbatore - 641062

MG Madurai
PPS Motors Private Limited

3S Shed No. D-23, Nilaiyur First Bit, Uchapatti
Village, Thirumangalam, Madurai - 625402

MG Madurai - Tirunelveli
PPS Motors Private Limited

Z-Next 3S
Sy No 46/2, Palayamkottai Taluk,
Munnirpallam, Tirunelveli, Tamil Nadu,
627356

MG Salem
PPS Motors Private Limited

3S S.NO.151/1, N.H.44, Bangalore Highway,
Mamangam Salem

MG Trichy
PPS Motors Private Limited

3S 31/3A, D/NO. Dindugal Mainroad, Ramji
Nagar, Punganur

MG Chennai Central - OMR
FPL Vehicles Pvt. Ltd.

EC New Plot no. 4, Old Plot no. 8, Developed
Plot, Industrial Estate for Electrical,
Electronics and Instruments Industry,
Perungudi, Chennai 600097

MG Chennai Central - Guidy Workshop
FPL Vehicles Pvt. Ltd.

2S Developed Plot No. 5, South Phase, Thiru
Vi. Ka. Industrial Estate, Guindy, Chennai -
600032

MG Chennai Central - StudioZ
FPL Vehicles Pvt. Ltd.

1S 142, GF-41 Ground Floor Phoenix, Velachery
Main Road, GF-41 Ground Floor Phoenix
Marketcity Velachery, Chennai, T.N. 600042

MG Ambattur
FPL Vehicles Pvt. Ltd.

1S SP 98, Southern Avenue Road, Ambattur
Industrial Estate, Chennai - 600058

MG Chennai Ambattur Workshop
FPL Vehicles Pvt. Ltd.

2S B5, SIDCO Industrial Estate, Ambattur

MG Chennai Ambattur - Hosur
FPL Vehicles Pvt. Ltd.

Z-Next 3S
S.No 831/2, 832/2, Moranapalli Village, Hosur
Taluk, District, Krishnagiri, T.N - 635109

MG Chennai Central - Vellore
FPL Vehicles Pvt. Ltd.

Z-Next 3S
33/5A1, Chennai Bangalore Highway,
Perumugai, Vellore - 632009

MG Trichy Thanjavur
PPS Motors Private Limited

Z-Next 3S
SY. No:133/4, New SY. No:133/4A1A,
Papammal Pannerseivam Nagar,
Nanjikottaivattam Village

**MG Coimbatore Erode
PPS Motors Private Limited**

Z-Next 3S

1/320, Veppampalayam, Pichandampalayam,
Perundurai Main Road, Kadirampatti Post,
Erode

TELANGANA

**MG Hyderabad Banjara Hills
Raam4Wheelers LLP**

IS 8-2-120/86/10,10A,11B,11C and 11D, Opp:
Hotel Park Hyatt, Road Number 2, Banjara
Hills, Hyderabad - 500033

**MG Hyderabad Kondapur
Raam4Wheelers LLP**

3S Plot No.192,Serilingampally, Botanical Garden
Road, Camelot Place, Gouthami Colony,
Kondapur, Hyderabad - 500084

**MG Hyderabad Hi-Tech City -
Gachibowli
Raam4Wheelers LLP**

EC 7-56/19, Dargah Road, Radhe Nagar,
GachiBowli, Rai Durg - 500035

**MG Hyderabad Central - Balanagar
Raam4Wheelers LLP**

2S H. No. 7-8-188/3, Gautam Nagar, Balanagar,
Secunderabad - 500011

**MG Hyderabad Hi-Tech City - Attapur
Workshop
Raam4Wheelers LLP**

2S Plot No - 28, 29, Door no. 2-5-28, Survey No
30, Upperpally Village, Rajendra Nagar Mandal,
Hyderabad

**MG Hyderabad Hi-Tech City -
Nizamabad
Raam4Wheelers LLP**

ESN H.No.1-1-7/D/1A/10 Near Mannuru Kapur
Kalayana Madam, Pragathi Nagar, Nizamabad
- 503001

**MG Hyderabad Kukatpally - Khammam
Raam4Wheelers LLP**

ESN Junction H NO 10-6, 184/5, Bypass, Raparthi
Nagar, Khammam - 507002

**MG Hyderabad Central - Mahabubnagar
Raam4Wheelers LLP**

ESN Plot No. 1&3, Survey No.3A, Opp: SVS
Medical College, Near Chaitanya Central
School, Yenugonda, Mahaboobnagar - 509001

**MG Hyderabad Central - Warangal
Raam4Wheelers LLP**

Z-Next IS

H.No: 23-6-201/6/1, Madatha Towers
Dwaraka Nagar, Hunter Road, Hanamkonda,
Warangal Urban - 506002

**MG Hyderabad Central - Warangal
Raam4Wheelers LLP**

Z-Next 2S

12-8-301/10 Bondivagu, Beside Tafe
Showroom, Hunter Road, Near Greenwood,
Hanamkonda, Warangal - 506001

**MG Hyderabad Hi-Tech City -
Karimnagar
Raam4Wheelers LLP**

Z-Next 3S

Near Kaloji Statue, Adjacent To Mahaveer
Marble & Granites, Jagital Road, Rekurthi

**MG Hyderabad LB Nagar
PPS Motors Private Limited**

IS D.no.3-3-415, Mansoorabad,Saroornagar
Mandal, LB Nagar, Hyderabad

**MG Hyderabad LB Nagar
PPS Motors Private Limited**

2S Sy No 20, Bandlaguda Village,Opp.BPCL
Petrol Pump,Uppal Mandal, Hyderabad,
Telangana

**MG Hyderabad - Kukatpally
Raam4Wheelers LLP**

IS Plot No. 2 & 4, in survey No. 701, Block B,
MG - Kukatpally MM Plaza (Times Square),
Kukatpally Y Junction, Metro Pillar No : A
872, Moosapet, Balanagar Mandal, Medchal
Malkajgiri District

**MG Hyderabad Central - Balanagar
Bodyshop
Raam4Wheelers LLP**

- 2S H.no 6-3-10, Balanagar, Behind Smr Vinay
Capital, Hyderabad, Telangana, 500042

UTTAR PRADESH

**MG Noida
Crystal Autocars Private Limited**

- 3S No. D-2, Sector 8, Noida, UP - 201301

**MG Noida - Bulandshahr
Crystal Autocars Pvt. Ltd.**

- ESN Chandpur Village, Near MMR Mall, GT Rd,
Chandpur, Bulandshahr, U.P.- 203001

**MG Noida Electronic City
Frontier Automobiles Pvt Ltd**

- 1S H-1/A-4, Sector-63, Noida, Uttar Pradesh
201307

**MG Noida Electronic City
Frontier Automobiles Pvt Ltd**

- 2S H-158, Delhi - Meerut Expy, H Block, Sector
63, Noida, Uttar Pradesh 201301

**MG Lucknow Central+North Chinhat
Beeaar Autowheels India Pvt. Ltd.**

- 3S Milestone No. 111, Faizabad Road, Chinhat,
Lucknow - 227105

**MG Kanpur
Socmo Cars Private Limited**

- 1S 15/63, Rudra House, Civil Lines, Kanpur,
Uttar Pradesh-208001

**MG Agra
NRL Cars Pvt. Ltd.**

- 3S 404, Nagla Padi, Near Arvind Hyundai-282005

**MG Agra - Shahdara WS
NRL Cars Pvt. Ltd.**

- 2S MG Workshop, Shahdara Chungi,Taj
Expressway Link Road,Agra - 282007

**MG Agra - Aligarh
NRL Cars Pvt. Ltd.**

- Z-Next 3S
Old Niharika JP Force Showroom,Meharwal
GT Road , Near Meharwal Mod, Aligarh

**MG Varanasi
Puneet Car Sales Private Limited**

- 1S Andhrapull, Chaukaghat, Varanasi, Uttar
Pradesh 221002

**MG Varanasi Service
Puneet Car Sales Private Limited**

- 2S Grand Trunk Rd, Parao, Near Ambition
Institute of Technology, Varanasi - 221002

**MG Bareilly
Keshav Raj Automobiles Pvt. Ltd.**

- 3S 4.5 KM Rampur Road, C. B Ganj
Bareilly-243001

**MG Bareilly - Moradabad
Keshav Raj Automobiles Pvt. Ltd.**

- Z-Next 3S
Bhatawali, Kanth Rd, Opp. Hanuman Mandir,
next to Arjun Vasui Hyundai Service,
Moradabad, Uttar Pradesh

**MG Haldwani SR
Keshav Raj Automobiles Pvt. Ltd.**

- 3S Siddharth City Dewalchaur bandobasti
5KM Rampur road Jeetpur Negi Haldwani
Uttarakhand

**MG Prayagraj
Puneet Car Sales Private Limited**

- 3S Varanasi, Allahabad Road, Andanva, Jhusi
Khona UP - 211019

**MG Gorakhpur
Beeaar Autowheels India Pvt. Ltd.**

- 1S Vrindavan Towers, Medical College Road,
Basharatpur, Gorakhpur

**MG Jhansi
Socmo Motors LLP**

- 3S Society Trucking- Bharat Benz (old State Bank
Building), Digara, Kanpur Jhansi Road,
Jhansi - 208001

**MG Ghaziabad
Crystal Autocars Private Limited**

- EC Block G, Patel Nagar3, Ghaziabad, UP-201003

- MG Lucknow Central+North
Hazratganj
Beeaar Autowheels India Pvt. Ltd.**
- EC 10 Ashok Marg, Opposite GST Bhawan,
Hazratganj, Lucknow - 226001
- MG Meerut
Grand Vehicles (P) Limited**
- 1S Abhikarm, Civil Lines , Meerut U.P.-250001
- MG Meerut
Grand Vehicles (P) Limited**
- 2S CP 4, Shradhapuri Ph. 2, Kankarkhera, NH 58
Bypass , Meerut , UP-250001
- MG Kanpur Mech
Socmo Cars Private Limited**
- 2S 12/483, Macrobertganj, Kanpur, U.P. 208002
- MG Gorakhpur Service
Beeaar Autowheels India Pvt. Ltd.**
- 2S BL-7, Sector 15, GIDA, Sahjanwa UP
- MG Ghaziabad Service (Mechanical)
Crystal Autocars Private Limited**
- 2S Khasra No. 1336-1337, Mainapur Industrial
Area, Meerut Road, Ghaziabad
- MG Lucknow South-Transport Nagar
(Mechanical)
Beeaar Autowheels India Pvt. Ltd.**
- 2S E-28/49B, Near Parking no. 9, Transport
Nagar, Lucknow, UP

- MG Lucknow South - Transport Nagar
Beeaar Autowheels India Pvt. Ltd.**
- 1S Shop No- 001, GF, JB Metro heights, Kanpur
Road, LKO
- MG Kanpur Bodyshop
Socmo Cars Private Limited**
- 2S Gram Pakri Near Kishan Nagar Opposite
HP Petrol Pump Kanpur

UTTARAKHAND

- MG Dehradun
Grand Vehicles (P) Limited**
- 3S Saharanpur Road, Mahobewala Chowk, -
248002
- MG Haldwani Rudrapur
Keshav Raj Automobiles Private
Limited**
- Z-Next 3S
MG Rudrapur, Shukla Farm Near Teen Pani
Mod, Kiccha Road,Rudrapur,Uttarakhand
- MG Dehradun Roorkee
Grand Vehicles (P) Limited**
- Z-Next 3S
NH 58, Rehmadpur, Uttarakhand -247667

WEST BENGAL

- MG Kolkata South
Auto Hi-Tech Pvt. Ltd.**
- 1S 97A Southern Avenue, Kolkata 700029
- MG Kolkata North
Auto Hi-Tech Pvt. Ltd.**
- EC Eco Centre Ambuja Neotia, EM Block,
Sector V, Salt Lake City, Kolkata - 700091
- MG Kolkata Service
Auto Hi-Tech Pvt. Ltd.**
- 2S 34A C.N.Roy Road Kolkata 700029
- MG Siliguri
Siliguri Auto Works Pvt. Ltd.**
- 3S 2, 1/2 Mile, Sevoke Road, Siliguri
- MG Siliguri
Siliguri Auto Works Pvt. Ltd.**
- Z-Next 3S
MG Gangtok, Khangsarpa Building, Below
Tadong School, Tadong Bazaar, Gangtok, East
Sikkim.
- MG Durgapur
Auto Hi-Tech Pvt Ltd**
- ESN Mozunder Automobiles, Banskopa (Near
L&T More) Bamanara Durgapur , West
Bengal-713212

VEHICLE RECORD SHEET

MODEL																									
CHASSIS NO.																									
MOTOR NO.																									
KEY NO.																									
DATE OF DELIVERY																									
MILEAGE (KM)																									
BATTERY	MAKE										SR NO./ BATCH CODE														
TYRE	TYRE LOCATION					FR RH <input type="checkbox"/>					FR LH <input type="checkbox"/>					RR RH <input type="checkbox"/>					RR LH <input type="checkbox"/>				
	MAKE										BATCH NUMBER														

OWNER'S NAME & ADDRESS:															

ADDRESS OF SELLING DEALER

Showroom:															
Workshop:															

For any feedback, please call **Toll free No. 1800 100 6464**

www.mgmotor.co.in
1800 100 6464

MG Motor India Pvt. Ltd.

All information, illustrations and specifications contained in this Owner's Manual are based on the latest production information available at the time of publication. The right is reserved to make changes at any time without notice.

Version: 07/03/2024