



**ASHOK LEYLAND**  
*Koi Manzil Door Nahin*

---

# LNG

---

**Liquified Natural Gas Vehicle**



**HINDUJA GROUP**



# INTRODUCING A6 LNG 6X4 TRACTOR

The wheels of innovation are transforming the commercial vehicle industry at a rapid pace. Ashok Leyland leads this path of innovation by introducing the LNG long-haul tractor.

This vehicle is powered with A6 LNG Engine. Liquified nitrogen gas is stored in cryogenic tanks at  $-162^{\circ}\text{C}$ , allowing large volumes of fuel storage, thereby delivering the longest range in a single fill.

The LNG tractor is also equipped with backup CNG tanks. When the LNG fuel gets exhausted, the vehicle automatically switches to its CNG source.

Compared to conventional fuels, LNG and CNG have lower emissions.

The A6 LNG tractor's advanced and sustainable fuel system propels us towards a prosperous and greener future where  
Koi Manzil Door Nahin!





# KEY AGGREGATES



## Engine

- Engine: A6 LNG Engine
- Power: 240 kW @ 2200 rpm
- Torque: 1200 Nm @ 1200-1800 rpm

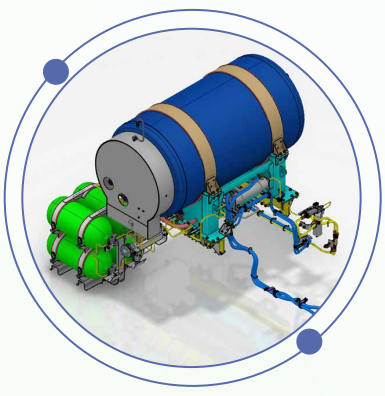

## Automated Fuel Selection System

- Tank Capacity;
  - LNG: 990 L (behind cabin)
  - CNG: 160 L (on chassis RHS)

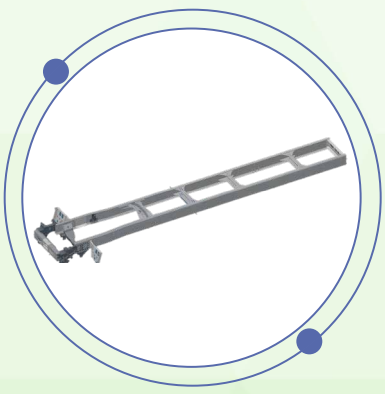

## AVTR Platform

- Heavy Duty aggregates
- HSS Frame

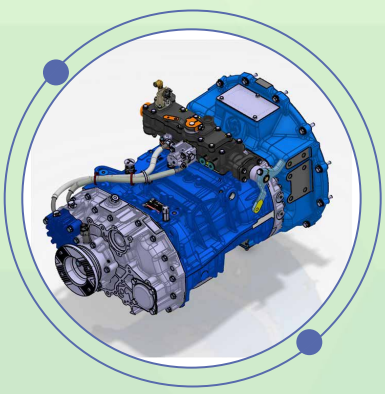

## Gearbox

- 9-speed synchromesh with crawler gear

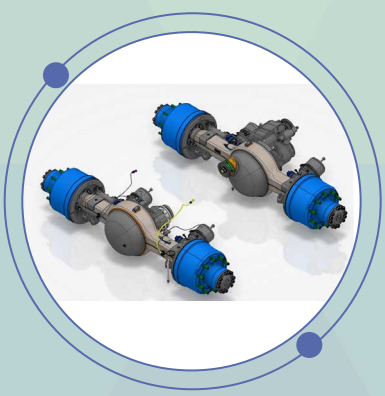

## Rear Axle

- Fully floating single reduction hypoid axle

# FEATURES

## India's first flexi fuel engine - LNG and CNG

Ashok Leyland is the first OEM in India to offer an engine with flexi fuel technology. Intelligent onboard system automatically switches from LNG to CNG and vice versa based on availability

## LNG offers a longer range than CNG

LNG being stored in liquid form, packs more energy than CNG in a lesser space – making it an ideal fuel for long-distance trucking requirements

## With proven aggregates from the AVTR modular platform

With over 1,50,000 + AVTR vehicles running on Indian roads. AVTR platform provides unmatched durability and vehicle uptime

## Can be offered on a wide range of vehicle configurations

With the modular AVTR platform, customers can configure vehicles based on their specific application and needs

## Premium N Cabin

Premium N cabin with Best-in-class features like tiltable – telescopic steering, suspended seats for driver comfort and less fatigue

# SCHEMATIC LAYOUT

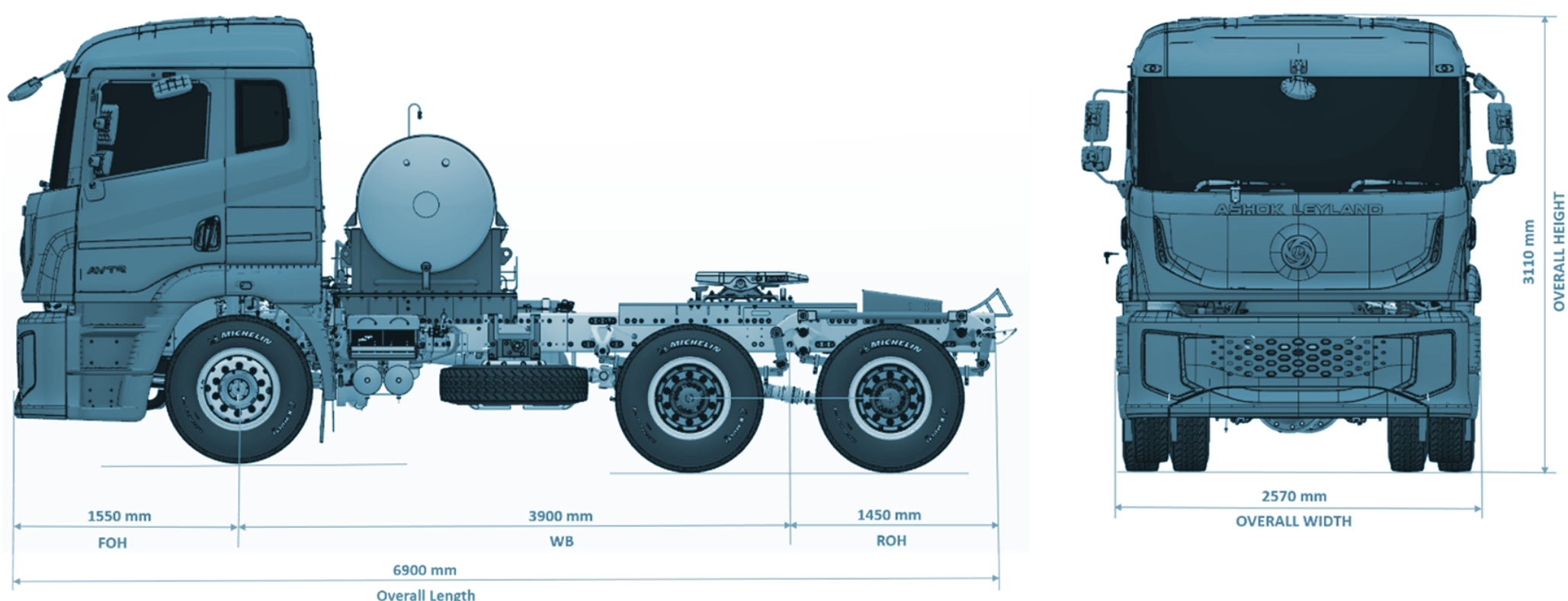

# A6 LNG 6X4 TRACTOR

## TECHNICAL SPECIFICATIONS

<b>GCW</b>	<b>55000 kg</b>
<b>Engine type</b>	<b>A Series 6 cylinder, LNG/ CNG engine</b>
<b>Max power</b>	<b>240 kW @ 2200 rpm</b>
<b>Max torque</b>	<b>1200 Nm @ 1200 – 1800 rpm</b>
<b>Clutch</b>	<b>430 mm diameter - with air assisted hydraulic booster</b>
<b>Gearbox</b>	<b>9-speed synchromesh with crawler gear</b>
<b>Front axle</b>	<b>Forged I section - Reverse Elliot type</b>
<b>Rear axle</b>	<b>Fully floating single reduction hypoid axle</b>
<b>Front suspension</b>	<b>Parabolic suspension</b>
<b>Rear suspension</b>	<b>Non-reactive suspension</b>
<b>Chassis frame</b>	<b>Bolted construction with constant width over chassis</b>
<b>Brakes</b>	<b>Full air dual line brakes with ABS</b>
<b>Tyres</b>	<b>Low resistance tubeless Tyre - 295/ 80 R22.5</b>
<b>Cabin</b>	<b>N - Premium cabin</b>
<b>Max speed</b>	<b>80 kmph</b>
<b>Wheelbase</b>	<b>3900 mm</b>
<b>Turning circle diameter</b>	<b>14300 mm</b>
<b>Fuel tank</b>	<b>1 x 990L LNG Cryogenic tank, 4 x 40L CNG tank (T1)</b>
<b>Vehicle configuration</b>	<b>Cabin chassis</b>





**ASHOK LEYLAND**

*Koi Manzil Door Nahin*

**Registered Office**

Ashok Leyland Limited, No. 1, Sardar Patel Road, Guindy, Chennai - 600032

**Telephone:** 91 44 2220 6000 | **E-mail:** reachus@ashokleyland.com

**Website:** www.ashokleyland.com | **Helpline Number:** 1800 266 3340

CIN: L34101TN1948PLC000105



**HINDUJA GROUP**